

Condensing Models

On-Demand Water Heater Service Handbook



MODELS:

ATI-140H-N

ATI-140H-P

ATO-140H-N

ATO-140H-P

GTS-140-NIH

GTS-140-PIH

GTS-140-NEH

GTS-140-PEH

GT-140-NIH

GT-140-PIH

GT-140-NEH

GT-140-PEH

T-H3M-DV-NG

T-H3M-DV-LP

T-H3M-OS-NG

T-H3M-OS-LP

**THIS SERVICE HANDBOOK IS FOR USE BY QUALIFIED SERVICE PROFESSIONALS ONLY.
IF YOU NEED ASSISTANCE, CALL TECHNICAL SUPPORT AT 877-737-2840.**

TABLE OF CONTENTS

Specifications.....	4
Introduction.....	5
General Installation Guidelines	5
Normal Operation	6
Activation	6
Operation	6
Shutdown	6
Troubleshooting	7
Preliminary Checklist	7
Gas/Water/Electric:	7
Remote Controller:	7
High Altitude:	7
Long Vent Run.....	7
Hard Water:	7
New Installations:	7
External Problem:	7
Next Step:	7
General Issues	7
Water is not hot enough.	7
Water is too hot.	8
Temperature fluctuates when a fixture is opened.....	8
Unit does not ignite when water goes through it.....	9
Abnormal sounds come from the unit.....	9
Error Codes.....	10
Incorrect DIP Switch Settings	12
Abnormal Combustion	12
Ignition Failure / Flame Loss	12
Outlet Thermistor Failure	13
Inlet Thermistor Failure	13
Exhaust Thermistor Failure	14
Air-Fuel Ratio Rod Failure	14
Abnormal Solenoid Gas Valve	14
Abnormal Fan Motor	15
False Flame Detection	16
Remote Control Problem	16
Abnormal Exhaust Temperature	17
Abnormal Combustion	17
Dip Switch Settings.....	19
Wiring Diagram.....	22

Service Procedures.....	24
Verifying DIP Switch Settings	24
Unit Draining and Filter Cleaning.....	24
Checking for a Crossed Connection	25
Checking for a Reversed Connection	25
Checking Inlet Gas Pressure/Purging Air from Gas Line	25
Checking and Adjusting the Manifold Gas Pressure	25
Adjusting Minimum Manifold Pressure	26
Checking the Overheat Cutoff Fuse (OHCF).....	27
Checking the Flow Sensor.....	27
Cleaning the Rod Assembly (Flame Sensor and Air/ Fuel Ratio Rod)	28
Descaling the Unit	29
Draining and Hose Connection	29
Pump And Descale	29
Cleanse the System	29
Cleaning the Combustion Components.....	29
Maintenance	35
Replacing the Heat Exchanger (Indoor Models)	37
Removing Heat Exchanger Components (Indoor Models).....	37
Preparing the New <u>PRIMARY</u> Heat Exchanger for Installation (Indoor Models).....	40
Preparing the New <u>SECONDARY</u> Heat Exchanger for Installation (Indoor Models)	41
Installing the Heat Exchanger (Indoor Models)	41
Replacing the Heat Exchanger (Outdoor Models)	46
Removing Heat Exchanger Components (Outdoor Models).....	46
Preparing the New <u>PRIMARY</u> Heat Exchanger for Installation (Outdoor Models).....	49
Preparing the New <u>SECONDARY</u> Heat Exchanger for Installation (Outdoor Models).....	50
Installing the Heat Exchanger (Outdoor Models)	50
Flow Sensor/Control Valve Removal and Installation	55
Removal	55
Installation	55
Burner Removal and Installation	56
Removal	56
Installation	59
Gas Valve/Manifold Plate: Removal and Installation.....	61
Removal	61
Installation	62
Component Diagrams/Item Numbers	67
Component Item Numbers.....	71

SPECIFICATIONS

Table 1: 140 (T-H3M) Direct Vent Indoor and Outdoor*				
Model		140 Indoor (T-H3M-DV)	140 Outdoor (T-H3M-OS)	
Natural Gas Input (Operating Range)	BTU/h	Min.: 15,000 Max.: 120,000		
Propane Input (Operating Range)	BTU/h	Min.: 15,000 Max.: 120,000		
Gas Connection		1/2" NPT		
Water Connection		3/4" NPT		
Water Pressure*	psi (MPa)	15 - 150 (0.1 - 1.0)		
Natural gas Inlet Pressure	inch W.C. (kPa)	Min. 5.0 (1.2) Max. 10.5 (2.6)		
Propane Inlet Pressure	inch W.C. (kPa)	Min. 8.0 (2.0) Max. 14.0 (3.5)		
Manifold Pressure**	Natural Gas	inch W.C. (kPa)	Min. 1.3 (0.32) Max. 3.3 (0.82)	
	Propane	inch W.C. (kPa)	Min. 1.1 (0.28) Max. 3.0 (0.75)	
Weight	lbs. (kg)	50 (22.5)	50 (22.5)	
Dimension	inch	H 21-3/4 x W 14 x D 9-1/4		
	mm	H 552 x W 352 x D 236		
Ignition		Electric Ignition		
Electric	Consumption	Supply	VAC/ Hz	120/60
		Operation	W/A	53.9/0.7
		Standby	W/A	3.2/0.05
		Freeze-Protection	W/A	223.9/1.94

* 40 psi (0.27 MPa) or above is recommended for maximum flow.

** The Manifold Pressure is the factory setting and should not need adjustment. NOTE: Manifold Pressure readings are taken with the front cover removed.

NOTE:

- Check the rating plate to ensure this product matches your specifications.
- In accordance with ANSI Z21.10.3, CO emission does not exceed 400 PPM for normal input.
- The manufacturer reserves the right to discontinue, or change at any time, specifications or designs without notice and without incurring obligation.

INTRODUCTION

Read and follow all safety messages and instructions in this handbook and on the product labeling.



This is the safety alert symbol. It is used to alert you to potential physical injury hazards. Obey all safety messages that follow this symbol to avoid possible property damage, serious injury or death. Do not remove any permanent instructions, labels, or the rating plate from either the outside of the water heater or on the inside of the access panels.

▲ DANGER indicates a hazardous situation that, if not avoided, will result in death or serious injury.

▲ WARNING indicates a hazardous situation that, if not avoided, could result in death or serious injury.

▲ CAUTION indicates a hazardous situation that, if not avoided, could result in minor or moderate injury.

▲ NOTICE indicates practices not related to physical injury.

▲ WARNING!

- Installation and service must be performed by a qualified installer (such as a licensed plumber or gas fitter). Otherwise, the warranty will be void.
- The installer/service agent (licensed professional) is responsible for correctly installing or servicing your water heater and for compliance with all national, state/provincial, and local codes.

This handbook provides the necessary information for troubleshooting the 140/T-H3M tankless water heaters. It will be effective in helping your troubleshooting needs as long as the instructions are followed in the

intended order. Here is how to use this manual:

- First, refer to the 140/T-H3M Installation Manual as the primary source of information. Refer to it along side this manual throughout the troubleshooting process.
- Before troubleshooting, if you are unfamiliar with how a tankless unit operates, read “Normal Operation” on page 6.
- To double-check or troubleshoot a new installation, use the 140/T-H3M installation manual.
- When beginning troubleshooting, first go through the “Preliminary Checklist” on page 7. It is designed to fix the most common and frequent problems and provide you with background information to help narrow down the information you need.
- If you have received an error code, refer to “Error Codes” on page 10. If you have not received an error code, refer to “General Issues” on page 7.
- Consider removing the following sections from this manual for easy reference:
 - “Component Diagrams/Item Numbers” (starting on page 67).
 - The following graphics, which show the location of basic components.
 - Indoor models: Page 35, Figure 24.
 - Outdoor models: Page 36, Figure 25.

This will allow you to lay the loose pages beside this manual for easier reference.

If you have any problems or questions regarding this equipment, or at any point become confused or uncomfortable with any of the

procedures, consult the technical service department or the local service agent.

General Installation Guidelines

1. Follow all local codes, or in the absence of local codes, follow the current edition of the National Fuel Gas Code: ANSI Z223.1/NFPA 54 in the USA or B149.1 (Natural Gas and Propane Installation Code) in Canada.
2. Properly ground the unit in accordance with all local codes or, in the absence of local codes, with the National Electrical Codes: ANSI/NFPA 70 in the USA or CSA standard C22.1, Canada Electrical Code, Part 1 in Canada.
3. Carefully plan where you intend to install your water heater.
4. Check the rating plate for the correct GAS TYPE, GAS PRESSURE, WATER PRESSURE and ELECTRIC RATING. See Figure 1. **NOTE:** If this unit does not match your requirements, do not install.

If any problem occurs, turn off all hot water taps and turn off the gas. Then call a trained technician or the gas company.

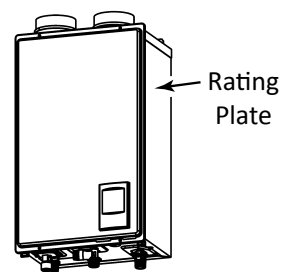

Figure 1.

NORMAL OPERATION

Becoming familiar with how a tankless water heater normally operates may help to troubleshoot it. Assuming it is properly installed with appropriate gas, water, and electrical connections, it should operate as follows:

Activation

1. A hot water tap is opened. The flow sensor detects a flow rate through the heater that is greater than the 0.5 GPM activation point. The system also verifies that the temperature difference between the incoming water and the set temperature is great enough to meet the 15,000 BTUH input requirement.

2. The fan activates after the conditions in the previous step are met.
3. Igniter activates. You can hear the buzzing of the spark igniter.
4. The main gas valve, proportional valve, and solenoid gas valves will open. You will hear a deep “clunk clunk” noise.
5. Once a flame is detected, the green “In Use” LED will activate. (This green LED is located on the temperature controller or remote controller.)

Operation

1. The proportional gas valve and fan will modulate based on the amount of hot water demanded and the temperature rise needed.
2. You may notice that only partial sections of the burner will be lit. This is normal operation. There are three sections on the burner assembly, and the computer controls the number of sections needed based on the flow rate and temperature rise required.
3. The water control valve within the unit may restrict water flow to ensure that the set temperature will be met.

Shutdown

1. The heater will shut down when the water flow rate drops below the deactivation point of 0.4 GPM.
2. The heater will close the main gas valve and solenoid gas valves, then extinguishing the flame.
3. When the flame disappears, the green “In Use” LED will turn off.
4. The fan will increase in speed to purge the venting of any remaining exhaust gases. The length of post-purge can last up to 1 ½ minutes.
5. The heater goes into standby and waits for the process to begin again.

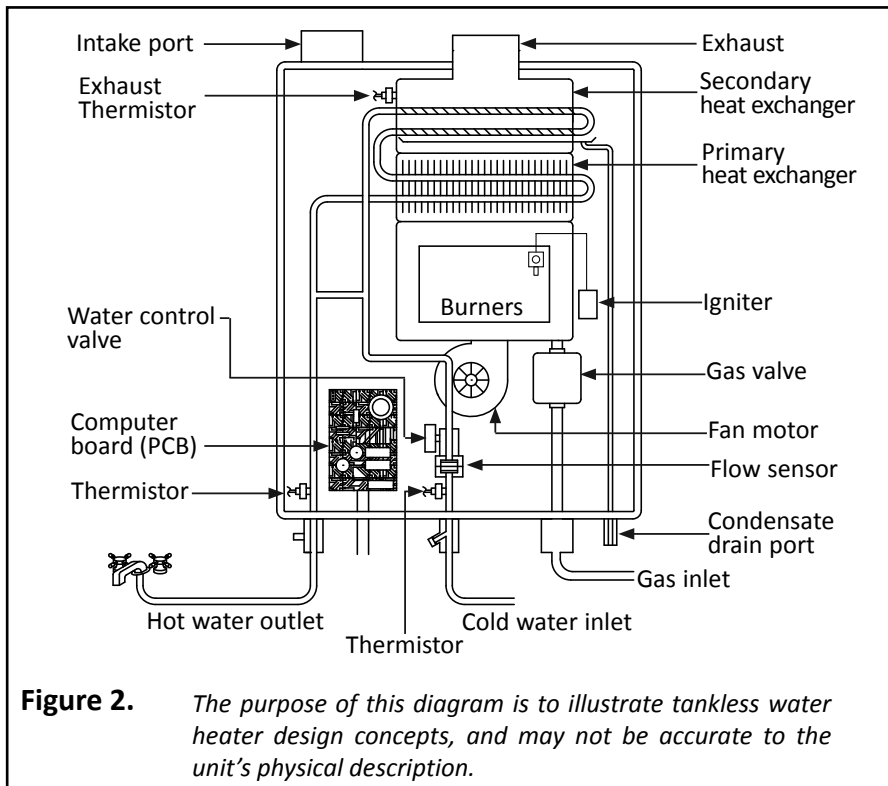

Figure 2. *The purpose of this diagram is to illustrate tankless water heater design concepts, and may not be accurate to the unit's physical description.*

TROUBLESHOOTING

Preliminary Checklist

To get started, review the following topics. You may also refer to “General Issues,” if necessary.

Gas/Water/Electric:

- The gas supply valve should be fully open and the gas line purged.
- Verify that the correct gas type is being used. Check the supply gas, the gas type dip switch, and the gas type shown on the rating plate. All three must agree in terms of gas type, and your water heater model must be designed for use with that type of gas (natural gas or LP).
- The water supply valve should be fully open.
- The unit should be connected to a 120 VAC 60 Hz power supply. When the heater is in Stand By, the green LED on the computer board will be lit and the amber LED on the temperature/remote controller will be lit.
- If the power switch inside the unit is turned off, then the LEDs mentioned above will be off.

Remote Controller:

If you are using a remote controller, the remote’s power button must be turned on. The amber Stand-By LED will be lit.

High Altitude:

Is your location at an altitude of over 2,000 feet? This may cause a lack of air. See “Dip Switch Settings,” page 19.

Long Vent Run

Do you have a long vent run? You may see an unnecessary error due to back pressure in the venting. See “Dip Switch Settings,” page 19.

Hard Water:

What is the hardness of the water? A means of reducing scale is always recommended, but if the water is above 7 grains of hardness or 70-140 ppm, one must be installed. If there isn’t anything installed, existing installations will gradually accumulate scale buildup on the heat exchanger and cause a leak. Heat exchanger leaks due to hard water scale are not covered under the warranty.

New Installations:

A new installation that does not function properly is most likely caused by reverse plumbing or a dirty inline water filter.

External Problem:

- Test whether the problem is within the unit or external to the unit (i.e., in the plumbing system) by attempting to run hot water locally through the isolation valve. Ensure that the hot water shutoff is closed while running water through the hot isolation valve drain port.
- Does the heater ignite and remain running properly? Or does the heater shut down with an error

code? If it runs well through the hot isolation valve, the plumbing system is at fault.

Next Step:

Finally, check to see if the unit has an error code. The error code will be displayed on the temperature controller (or remote controller) and by flash codes on the green LED on the computer board. See Figure 3, page 10. See also the error code chart on page 10.

- If it is displaying an error code, proceed to “Error Codes” on page 10.
- If there is no error code, proceed to “General Issues.”

General Issues

Proceed to the “Error Codes” section if an error code is identified. For other common problems that do not involve error codes, see if the following items help:

Water is not hot enough.

- What is the set temperature of the heater? Temperature can be adjusted using the temperature or remote controller.
 - Isolate the heater by closing the hot isolation valve. Open the hot drain valve and test the heater. A hose may need to be connected to the hot drain prior to opening it in order to drain the water properly.
 - If the temperature and flow rate are correct through the drain, then the problem

resides in the plumbing line, not in the tankless unit.

- Check for crossed plumbing between cold water lines and hot water lines. See the “Service Procedures” section for instructions.
- Unit may be hard water scaled. The scale acts as an insulator preventing the heat exchanger from transferring heat to the water. Refer to “Descaling the Unit,” page 29.
- The unit may not be receiving enough gas.
 - The gas supply valve may not be fully open.
 - The gas line may be sized improperly.
 - The gas supply pressure may be too low. This may be caused by a malfunctioning gas supply regulator, so check to see if the regulator is working properly. See “Check gas supply” later in this section.
- If a recirculation system is installed, ensure that a check valve is installed between the pump discharge and the connection to the cold water supply. Inspect the check valve for proper operation. If there isn’t one installed, or if it is malfunctioning, cold water may be back-feeding into the system.
- If a mixing valve is installed, check to see if it is operating properly and not allowing water to cross over.
- A 101 error code will reduce the amount of gas input into the heater. If the heater is displaying a 101 error code, see “Abnormal Combustion” on page 12.

- Output temperature will be affected if air flow is impeded.
 - Check for construction dust and debris in venting, such as dry wall dust.
 - If there is dust inside the cabinet, there will also be dust inside the burner and heat exchanger. Refer to “Cleaning the Combustion Components,” page 29.

Water is too hot.

- The temperature setting may be set too high. Adjust the temperature using the temperature controller or the remote controller.
- The flow adjustment valve could be obstructed due to hard water scale or debris, causing lower than expected water flow. Verify water flow with a graduated container or with the remote temperature controller, if one is installed.
- The output thermistor could be compromised. This component may be checked by entering the Diagnostics Mode on the remote controller or temperature controller. Turn power off to the unit and run cold water through it; check to see if the inlet and outlet temperatures read the same on the remote. Press the INFO button once on the temp/remote controller. The inlet water temperature will be displayed. Press the INFO button again to show the outlet temperature. If the readings are not similar, then one of the thermistors may not be reading correctly. Refer to error codes 311 and 321 in “Error and Flash Codes” (p. 10).

Temperature fluctuates when a fixture is opened.

Make sure that the unit is installed properly.

- Test whether the problem is within the unit or external to the unit (i.e., plumbing system).
- Plumbing connections:
 1. Check for a crossed connection. See “Checking for a Crossed Connection,” page 25.
 2. Problems with the recirculation system:
 - Make sure that a check valve is installed between the pump discharge and the connection to the cold water supply.
 - Check to see if the pump is operating properly.
 - Check for air cavitation. If present, the pump will be very hot or chattering.
 - Check the directional indicator on the pump flange.
 - Check the sizing of the pump. A minimum flow of 2 gpm is required.
- Check gas supply:
 - Verify that the gas meter is capable of supplying sufficient gas supply to all gas appliances. Determine the sum of all gas appliances’ maximum energy input (in cubic feet per hour). This number must be less than the maximum ratings shown on the gas meter’s rating

plate. If the maximum energy input of all appliances exceeds the maximum rating of the gas meter, consult your local gas utility.

- For LP models, there may not be enough gas left in the propane tank.
- Verify that the supply gas pressure is within specification, not only when the heater is in standby, but also while the heater is running on maximum fire. (See “Checking Inlet Gas Pressure/Purging Air from Gas Line” on page 25.)
- The gas supply pressure may be too low. This may be caused by a malfunctioning gas supply regulator.
- Check the pressure difference between static and maximum operating pressure. If the drop is more than 1 inch W.C., there may be insufficient gas supply. NOTE: In Canada, do not exceed the maximum allowable pressure drop permitted by B149.1.
- Venting:
 - Verify that the venting is installed to manufacturer’s specifications.
 - Verify that the vent run does not exceed the allowable limit. Refer to the installation manual.
 - Verify that the DIP switch settings for vent length match the installation’s equivalent vent length and diameter.
- The filter on the cold water inlet should be clean. Look for signs of hard water scaling. See “Unit Draining and Filter Cleaning” (p. 24).

- If the clear tube from the proportional gas valve to the bottom of the combustion chamber is disconnected, fluctuations in temperature and/or very low flow to the fixtures may occur.
- On well systems or even on some city water systems, water pressure fluctuations (especially on low flow) of 8 to 10 psi will result in flow rate fluctuations. This may result in minor temperature fluctuations.
- Flow sensor or water control valve may be compromised. Inspect both parts for blockages or debris.

Unit does not ignite when water goes through it.

- If you use the remote controller, is the remote power button turned on?
- Check to see if the Computer board is receiving power. This can be verified by observing the green LED on the computer board or the amber LED on the temperature/remote controller.

If it is not lit, the computer board is not being powered. Check to see if the ON/OFF switch below the fuse box is set to the on position, or if the fuse in the fuse box assembly is blown.

- Is the flow rate over 0.5 gpm? See if the unit initiates when you increase demand of water being drawn through the unit (e.g., opening up more hot fixtures). You can verify the flow rate by pressing the info button on the front of the unit until the arrow lights up beside “flow.”

- If the unit is in a recirculation system, the return water temperature may be too close to the set point temperature to activate the water heater. You can verify the incoming water temperature by using the information button on the front of the unit.
- Check that the gas line is open and is purged of air (page 25).
- Check that the filter on the cold water inlet is clean (page 24).
- Check for a reversed connection of the plumbing to the water heater or a crossed connection in the plumbing system. See page 25.
- Check for problems with the recirculation system.

Make sure that a check valve is installed between the pump discharge and the connection to the cold water supply. A malfunctioning or missing check valve will cause a cross connection, allowing cold water to back-feed into the system.

- If the fan does not initiate at all and it is verified that there is power to the unit, the flow sensor may not be working properly. Check the flow sensor for proper impeller functionality.

Abnormal sounds come from the unit.

- Check the fan for debris.
 - Check for blockages in the exhaust vent and intake air line.
 - Check for proper gas supply pressure.
- Contact the technical service department.

Error Codes

All units have self-diagnostics for safety and convenience when troubleshooting.

If there is a problem with the unit, a numerical error code will display on the TM-RE42 Remote Controller (if installed) or on the temperature controller of indoor models. Installation-related problems may also produce an error code. If the remote/temperature controllers are not working, the green LED on the computer board will flash a code pattern. (The green LED is located just above the DIP switches as shown in Figure 3.)

Figure 3. Green LED on Computer Board

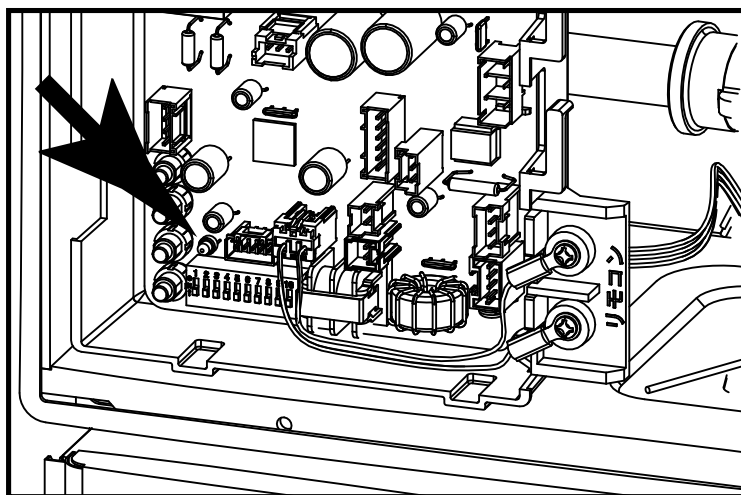

Figure 4. TM-RE42 Remote Controller



Table 2: Error and Flash Codes

ERROR CODE	GREEN LED ON COMPUTER BOARD	SYMPTOM OR ISSUE	TROUBLESHOOTING PROCEDURE
031	One Flash	Incorrect DIP switch setting	<i>Incorrect DIP Switch Settings, p. 12.</i>
101	Five Flashes	Abnormal Combustion (lockout is imminent)	<i>Abnormal Combustion, p. 12.</i>
111 or 121	Three Flashes	Ignition failure / Loss of flame	<i>Ignition Failure / Flame Loss, p. 12.</i>
311	Two Flashes	Outlet thermistor failure	<i>Outlet Thermistor Failure, p. 13.</i>
321	Two Flashes	Inlet thermistor failure	<i>Inlet Thermistor Failure, p. 13.</i>
341	Two Flashes	Exhaust thermistor failure (indoor models only)	<i>Exhaust Thermistor Failure, p. 14.</i>
391	Two Flashes	Air-fuel ratio rod failure	<i>Air-Fuel Ratio Rod Failure, p. 14.</i>

(Continued on next page.)

(Continued from previous page...)

ERROR CODE	GREEN LED ON COMPUTER BOARD	SYMPTOM OR ISSUE	TROUBLESHOOTING PROCEDURE
510	Six Flashes	Abnormal main OR abnormal solenoid gas valve	<i>Abnormal Main/Solenoid Gas Valve, p. 14.</i>
551	Six Flashes	Abnormal solenoid gas valve	<i>Abnormal Solenoid Gas Valve, p. 14.</i>
611	Four Flashes	Fan motor fault	<i>Abnormal Fan Motor, p. 15.</i>
701	One Flash	Computer board fault	<i>Proportional Gas Valve / Computer Board Fault, p. 16.</i>
711	One Flash	Gas solenoid valve drive circuit failure	<i>High Limit Switch / Overheat Cutoff Fuse Circuit is Compromised, p. 16.</i>
721	Six Flashes	False flame detection	<i>False Flame Detection, p. 16.</i>
741	N/A	Miscommunication between water heater and remote controller	<i>Remote Control Problem, p. 16.</i>
751	N/A	Miscommunication between water heater and temperature controller (Indoor model only)	<i>Temperature Controller Problem, p. 17.</i>
941	Five Flashes	Abnormal exhaust temperature (Indoor model only)	<i>Abnormal Exhaust Temperature, p. 17.</i>
991	Five Flashes	Imperfect Combustion	<i>Abnormal Combustion, p. 17.</i>

Incorrect DIP Switch Settings

Error Code: 031

1. Turn off the power supply.
2. Remove front cover and locate the DIP switches at the bottom of the computer board.
3. Refer to “Table 5: DIP Switch Settings”, p. 19. Table 5 lists the correct DIP switch positions.
NOTE: Before you change the DIP switch settings, turn off power to the heater by using the switch above the computer.

Abnormal Combustion

Error Code: 101

This code is a warning that the air-fuel ratio for combustion is gas rich. The heater will continue to operate with this error code, but a shutdown is imminent if the problem is not resolved. The next step is a 991 error code which will force the water heater to shut down.

Refer to “Error Code: 991,” page 17.

Ignition Failure / Flame Loss

Error Codes: 111 or 121

Either the water heater will not fire after three failed attempts at ignition (code 111) or it is not firing consistently (code 121).

These codes can appear due to a component in the heater or due to an external cause, such as no gas supply.

These codes will automatically reset when water stops moving through the heater or when the power is turned off, then back on again.

1. Verify that the gas supply pressure is within specifications when the heater is in standby and when the heater is trying to light. Also, verify that the

gas line is cleared of debris.

- It is possible that there is a faulty pressure regulator at the gas meter.
 - For propane units, colder periods of the day result in a cold regulator and may cause this problem.
2. Check the High Limit Switch and Overheat Cutoff Fuse (OHCF) as follows:
 - Turn off power to the water heater, then turn it back on. (Use the switch above the computer board.) Listen for the “clunking” noises of the gas solenoid valves. If you DO hear them, skip the remaining bullet points and go to step 3.
 - Turn off power to the heater by disconnecting the power cord or external switch.
 - Locate the high limit switch (item 411, p. 70). See also Figure 24 on page 35.

Push the button in the middle of it. The switch was reset if you heard and felt the button click.

Turn the power back on and test the heater. If the unit fires on, the cause of the high limit trip must be determined. Continue with the troubleshooting process.

If the high limit switch trips again, replace the high limit switch (part number 319143-228) However, if the high limit switch tripped and the heater is in a hard water environment, the heater may be scaled up. See “Descaling the Unit” on page 29.

- Refer to “Checking the Overheat Cutoff Fuse (OHCF)” on page 27.

3. Make sure that the clear plastic tube connecting the proportional gas valve to the combustion chamber is attached. See Figure 6. If necessary, see also Figure 33 (p. 41) and Figure 37 (p. 42).
4. Check the igniter for a spark. The spark may be viewed through the sight glass located next to the igniter and flame sensor. A strong blue spark will remain steady and in place, while a weak spark will jump around.
 - 4.1 If no spark or a weak spark is observed, check the igniter wire connections and make sure that these are secure.
 - 4.2 Check the igniter rod to make sure the black wire is properly attached and that the rod doesn’t move. If it moves, replace the igniter rod, part 320273-357. You will also need a gasket, part 319143-034.
 - 4.3 When the igniter is sparking, check the voltage across the purple wires coming to the igniter. Normal voltage is 108-132 VAC. If voltage is outside of this range then replace the computer board, part #320273-369.
 - 4.4 If the previous steps still don’t result in a spark being generated, replace the igniter (part 320273-381).
5. If flame comes on for only 1-2 seconds before going out, verify that the green IN USE LED on the built-in controller or remote controller did not turn on. If the LED stayed off, then inspect the flame sensor. Clean it if necessary. Replace it if any damage (chips or cracks in the ceramic) is seen or if the metal rod can move

freely in the ceramic insulator. See "Cleaning the Rod Assembly (Flame Sensor and Air/ Fuel Ratio Rod)" on page 28.

Unplug both ends of the wiring harness from the igniter assembly and control board, then reconnect them to ensure good connection. Also, verify that the green wire that is part of the circuit is attached to one of the screw connections around the manifold.

6. Verify proper operation of the gas solenoid valves. To do so, turn the power off, then check the resistance of the valves. A normal resistance reading for SV1 and SV2 is 1.35-1.65 kΩ. Normal resistance for SV3 is 2.07-2.53 kΩ. If the resistance is out of range, replace the gas valve. (Natural gas: part 320273-356, LP: part 320273-354.)
7. Check for blockages in venting, such as bird nests, animals, or trash.

Outlet Thermistor Failure

Error Code: 311

See also "Wiring Diagram," page 22.

1. Check that the wire connections are secure and free of burns or cuts. The outlet thermistor is embedded in the water outlet connection. (See item 408 on page 70.)
2. Check the resistance value. See page 15 for a list of normal resistance values.
3. Clean the thermistor.
 - a. Drain the unit of water. (See "Unit Draining and Filter Cleaning" on page 24.)
 - b. Remove the computer board to access the outlet thermistor. The computer is fixed in place by a single screw at the top of the board.
 - 3.1 Remove the screw, then pull out the sensor probe. Clean the probe to a silver finish. Do not lose the red rubber

o-ring that wraps around this sensor.

- d. Replace and test.

4. If the error code persists, replace the thermistor. (Thermistor part no.: 319143-529).

Inlet Thermistor Failure

Error Code: 321

See also "Wiring Diagram," page 22.

1. Check that the wire connections are secure and free of burns or cuts. The inlet thermistor is embedded in the water inlet connection. (See item 407 on page 70.)
2. Check the resistance value. See page 15 for a list of normal resistance values.
3. Clean the thermistor.
 - 3.1 Drain the unit of water. (See "Unit Draining and Filter Cleaning" on page 24.)

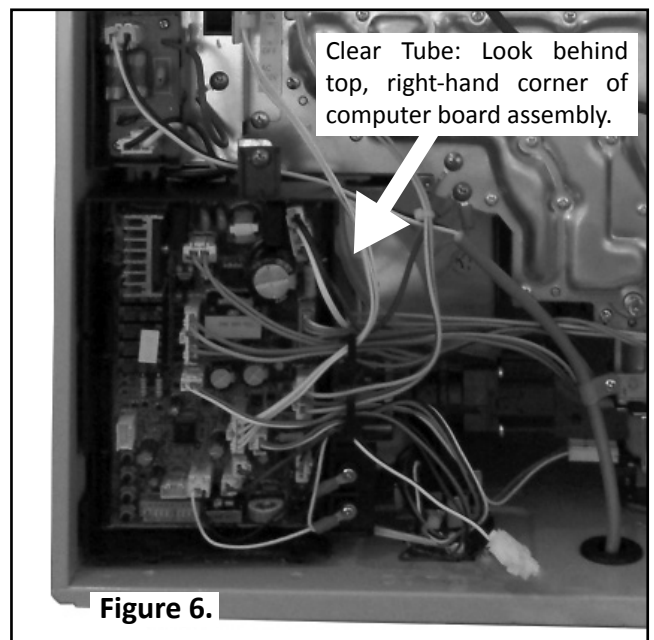
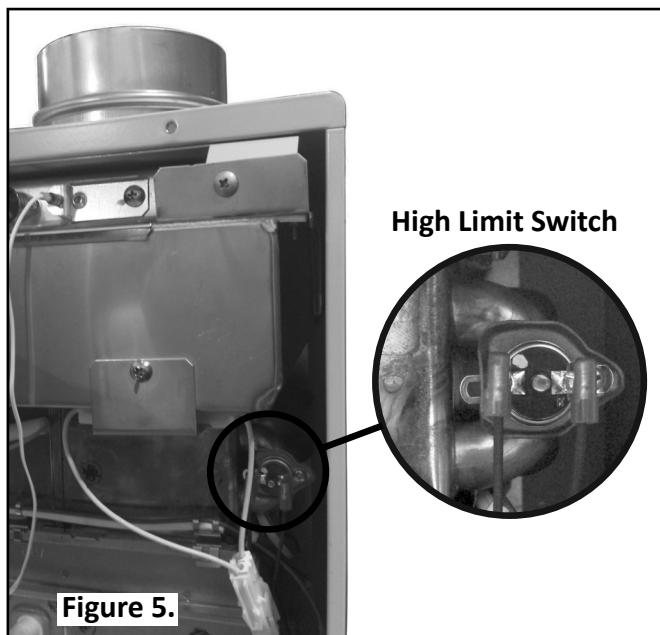

- 3.2 Remove the computer board to access the inlet thermistor. The computer is fixed in place by a single screw at the top of the board.
- 3.3 Remove the screw, pull out the sensor probe. Clean the probe to a silver finish. Do not lose the rubber o-ring that wraps around this sensor.
- 3.4 Replace and test.
4. If the error code persists, replace the thermistor. (Thermistor part no. 319143-214.)

Exhaust Thermistor Failure

Error Code: 341

This code will only appear on the indoor models.

1. Check the wire connections to the exhaust thermistor. They must be secure and free of burns or cuts. The exhaust thermistor is located at the top, center of the unit, above the secondary heat exchanger.
2. Check the resistance of the thermistor. See Table 3 and Table 4 for lists of normal resistance values.
3. Clean the thermistor.
 - 3.1 Remove the screw holding the thermistor plate, then pull out the sensor probe.
 - 3.2 Clean the probe to a silver finish. Do not lose the white gasket that seals this sensor.
 - 3.3 Replace and test.
4. If the error code persists, replace the thermistor. (Thermistor part nos: 319143-131 and 319143-111.)

Air-Fuel Ratio Rod Failure

Error Code: 391

1. Ensure that the unit is plugged into a socket that is properly grounded. A floating ground can cause this error.
 1. Check that the wire connections are secure and free of burns or cuts.
 2. Check that the clear plastic tube connecting the proportional gas valve to the combustion chamber is attached. See Figure 6.
 3. Clean the air-fuel ratio rod (flame rod). See "Cleaning the Rod Assembly (Flame Sensor and Air/Fuel Ratio Rod)" on page 28.

Abnormal Main/Solenoid Gas Valve

Error Code: 510

Driving circuit fault for the main or solenoid gas valves is not normal.

1. If the hot water is shut off, but flames are still visible through the burner sight window, immediately shut off gas and power to the unit and contact the technical service department.
2. Check the wire connections to the main gas solenoid valve for burns or cuts.
3. If the unit was recently rebuilt, make sure that each gas valve wire is plugged into the proper place. (For each connector, the number stamped on the metal must match the number that is printed on the wire's label. See Figure 7.)
4. Verify that the supply gas pressure is within the specified limits. Too high of an inlet gas pressure may cause the main gas valve to jam or could be damaged.

5. Check the voltage across the main gas valve wires (blue - light blue #3) during operation. The voltage reading should be 93-120 VDC. If the voltage is not within normal range, replace the computer board, part number 320273-369.
6. With the power off, check the resistance of the valve. Normal resistance reading is 1.35-1.65 k Ω . If the resistance is out of range, replace the gas valve, NG: part 320273-356, LP: part 320273-354.

Abnormal Solenoid Gas Valve

Error Code: 551

Driving circuit fault for the solenoid gas valves is not normal.

1. If the hot water is shut off, but flames are still visible through the sight glass, immediately shut off gas and power to the unit and contact the technical service department.
2. Check the wire connections to the gas solenoid valves for burns or cuts.

Figure 7. Gas Valve Wiring

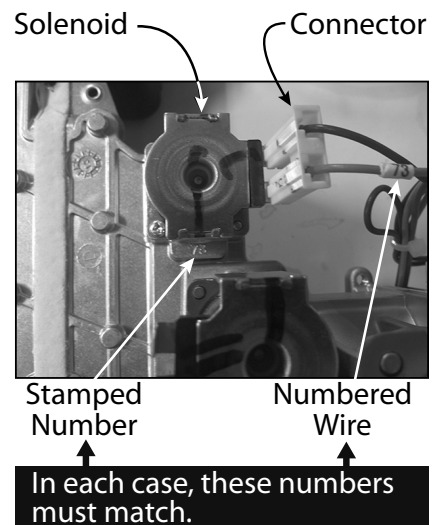

- If the unit was recently rebuilt, make sure that each gas valve wires are plugged into the proper place.
- Verify that the supply gas pressure is within the specified limits. Too high of an inlet gas pressure may cause the main gas valve to jam or could be damaged.
- Check the voltage across each solenoid gas valve wire during operation. The blue wire is common.

- SV1: Green, #9
- SV2: Orange, #53
- SV3: Red, #73

The voltage reading should be 93-120 VDC. If the voltage is not

within normal range, replace the computer board, part number 320273-369.

- With the power off, check the resistance of the valve. Normal resistance reading for SV1 and SV2 is 1.35-1.65 k Ω . Normal resistance reading for SV3 is 2.07-2.53 k Ω . If the resistance is out of range, replace the gas valve, NG: part 320273-356, LP: part 320273-354.

Abnormal Fan Motor

Error Code: 611

- Turn off power supply.
- Check fan motor wiring for breakages, burn marks on the

computer board (PCB), or moisture. If moisture is found, allow the connection to dry completely before turning power back on.

- Check fan housing for water. If found, please dry the fan, then test heater. If there is a significant amount of water, there may be a heat exchanger leak.
- To remove the fan, follow steps 1 through 10 in "Removing Heat Exchanger Components (Indoor Models)" (p. 37). When you are finished, reassemble in reverse order.
- If the 611 error code still appears after all items have been checked, the PCB may need replacement. Contact the technical service department.

TABLE 3: RESISTANCE VALUES OF THE TEMPERATURE THERMISTORS (INDOOR AND OUTDOOR MODELS)

TEMPERATURE	$^{\circ}\text{F}$	32	41	50	59	68	77	86	95	104	113
	$^{\circ}\text{C}$	0	5	10	15	20	25	30	35	40	45
RESISTANCE	K Ω	23.76	19.08	15.43	12.56	10.28	8.47	7.02	5.85	4.90	4.12

TEMPERATURE	$^{\circ}\text{F}$	122	131	140	149	158	167	176	185	194	203	212
	$^{\circ}\text{C}$	50	55	60	65	70	75	80	85	90	95	100
RESISTANCE	K Ω	3.49	2.96	2.53	2.16	1.86	1.60	1.39	1.21	1.05	0.92	0.81

TABLE 4: RESISTANCE VALUES OF THE TEMPERATURE EXHAUST THERMISTOR (INDOOR MODELS ONLY)

TEMPERATURE	$^{\circ}\text{F}$	32	41	50	59	68	77	86	95	104	113
	$^{\circ}\text{C}$	0	5	10	15	20	25	30	35	40	45
RESISTANCE	K Ω	30.04	24.12	19.50	15.87	13.00	10.71	8.87	7.39	6.19	5.21

TEMPERATURE	$^{\circ}\text{F}$	122	131	140	149	158	167	176	185	194	203	212
	$^{\circ}\text{C}$	50	55	60	65	70	75	80	85	90	95	100
RESISTANCE	K Ω	4.41	3.74	3.19	2.73	2.35	2.03	1.76	1.53	1.33	1.16	1.02

Proportional Gas Valve / Computer Board Fault

Error Code: 701

1. Verify that the red/white harness is connected at both the proportional valve solenoid and the computer board (PCB).
2. Inspect the computer board (PCB) for connection/breakage of wires and/or burn marks.
3. Check the operation of the outlet thermistor as follows:
 - 3.1 Push the on/off button on the temperature/remote controller so the STAND BY LED turns off.
 - 3.2 Run water through the heater.
 - 3.3 Check the reading of the outlet thermistor by pushing the INFO button on the temperature/remote controller two times. Compare it to the inlet thermistor. The readings should be similar and it should be reading the temperature of the supply water. If there is a difference of more than five degrees, go to Error Code 311, then retest the heater.
4. Check the proportional gas valve as described in the following sub-steps. The proportional valve is located at the bottom of the gas valve assembly and has red and white wires connected to it.
 - 4.1 Turn off the power supply.
 - 4.2 Check all wire connections and make sure that they are secure and free of burns or cuts.

5. Verify that supply gas pressure is within specifications.
6. Check the resistance across the proportional valve (red, white wires). Normal value is 20-40 Ω . If the resistance is outside this range, replace the gas valve. NG part 320273-356, LP part 320273-354.

High Limit Switch / Overheat Cutoff Fuse Circuit is Compromised

Error Code: 711

When power is turned on to the heater, the computer takes approximately 20 seconds to boot up. During this time, the computer is checking the gas valve, high limit, and Overheat Cutoff Fuse (OHCF) circuits. If any of these are compromised, this code will appear.

1. Inspect the dark blue common wire to the high limit switch, the OHCF, and the gas valves for any breaks or cuts.
2. Verify proper wiring harness connections to the gas valve solenoids. (For each connector, the number stamped on the metal must match the number that is printed on the wire's label. See Figure 7, page 14.)
3. Check the High Limit switch. Refer to "Ignition Failure / Flame Loss" on page 12.
4. The Overheat Cutoff switch may be compromised. Refer to "Checking the Overheat Cutoff Fuse (OHCF)" on page 27.
5. There may be a computer board (PCB) and/or gas valve fault. Refer to error codes 510 and 551.

False Flame Detection

Error Code: 721

1. **▲ WARNING! Shut off all gas and power to the unit.** The problem could be the flame sensor, but if it isn't, this is a very dangerous situation.
2. Inspect the flame sensor. Clean it if necessary. See "Cleaning the Rod Assembly (Flame Sensor and Air/ Fuel Ratio Rod)" on page 28.
3. Contact the technical service department for further assistance.

Remote Control Problem

Error Code: 741

This error code only occurs when there is a miscommunication between the temperature remote controller and water heater. This code is not for the built in controller on the indoor models. (Remote controllers for outdoor models will vary in the field. Prior to April 2015, outdoor models were equipped with remote controller TM-RE40/9008172005; current outdoor models are equipped with TM-RE42/9009069005.)

1. Make sure that all wiring is connected to the remote controller properly.
2. Verify that only a single remote is installed. With indoor models, only one remote may be used in addition to the built-in temperature controller.

An incorrect remote or multiple remotes will result in this error code. If an incorrect remote is installed, a 741 or 74 code will appear.

If you disconnect the remote from the heater with the power supply

on, this error code will result. Turn off power before disconnecting the remote from the heater.

3. Check for any signs of power surges.
4. Check the voltage across the wires coming to the remote. Normal voltage should be 10-25 VDC. If within normal range, replace the remote, part 9009069005. If the voltage is out of range, replace the computer board, part 320273-369.

Temperature Controller Problem

Error Code: 751

This code is only for the built in controller on the indoor models. (TM-RE41 is printed on the front, lower portion of the controller.) This error code only occurs when there is a miscommunication between the temperature controller (320273-684) and water heater. This code is not for the remote controller (TM-RE40/9008172005).

1. Check that all wiring is properly connected to the temperature controller (320273-684).
2. Check for any signs of power surges.
3. Check the voltage across the wires that are connected to the remote. Normal voltage should be 11-25 VDC. If within normal range, replace the temperature controller, part 320273-684. If the voltage is out of range, replace the computer board, part 320273-369.

Abnormal Exhaust Temperature

Error Code: 941

This code indicates that the exhaust temperature exceeded limits and that

the heater was not able to reduce the exhaust temperature, forcing the exhaust high limit switch to trip and shutdown the burners.

1. Check for excessive vent length and for any blockage in the intake air and/or exhaust.
2. Check for dust or lint in the burner and heat exchanger in contaminated installation areas.
3. Check the manifold pressure. See page 25.
4. Check the incoming water temperature. If it is above 140°F, the exhaust temperature may be too high. Reduce the supply water temperature.
5. Check the resistance of the thermistor. Refer to "Exhaust Thermistor Failure," page 14.

Abnormal Combustion

Error Code: 991

See also "Error Code: 101."

IMPORTANT: Familiarize yourself with the components before attempting these procedures. Use the Installation Manual and reference the component schematic on the last few pages of the manual.

Safety first! These procedures must be performed by licensed, qualified service professionals only. A.O. Smith is not liable for the actions of the technician if he/she fails to adhere to any or all safety procedures, specifically in regards to electrical and gas safety.

1. Verify the gas type of the heater and DIP switch position. The manifold plate will have a stamp on it to indicate the gas type.
NG: NG 88A
LP: LPG 88B

2. Verify the DIP switch settings.

- 2.1 Are the DIP switches set for the correct vent size and length? Refer to page 19 for correct settings. Each 90-degree elbow is equal to 5 feet of straight pipe.
- 2.1 Is the heater set to the correct elevation? Refer to page 20 for the correct elevation DIP switch settings.

Compare this to the information on the water heater's rating plate.

Is the gas supply pressure within specified limits when the heater is in standby and when it is running?

If the pressure difference between standby and maximum firing is greater than 1 inch W.C., the supply line and/or regulator may be undersized.

NOTE: In Canada, do not exceed the maximum allowable pressure drop permitted by B149.1.

Verify that the gas lines are sized for the correct volume of gas. Refer to the installation manual or the current edition of the National Fuel Gas Code, NFPA 54 (U.S.) or Natural Gas and Propane Code, B149.1 (Canada).

3. Check for obstructions in the vent or intake air lines. Clear them if any are found.
4. Verify that the terminations meet the minimum required clearances that are outlined in the installation manual and local codes.
5. Check for blockages or contaminants inside the heater cabinet, fan, burner, and around heat exchanger. If the fan is unable to push sufficient air, then the

burners will become gas rich and trigger the 101 or 991 code.

- To check and clean the burner, refer to “Cleaning the Combustion Components” on page 29.
- To check and clean the fan, see “Cleaning the Combustion Components,” page 29.

IMPORTANT: Do not proceed to the next step until this one has been completed and these causes have been ruled out. Lack of combustion air will affect manifold pressure readings.

6. Contact Technical Support regarding the manifold pressure. (See “Checking and Adjusting the Manifold Gas Pressure,” page 25). With approval from Technical Support, adjust the manifold pressure to the correct values, if necessary.
7. Complete the following procedure to reset the 101/991 error code:
 - 7.1 Make sure that the water heater is powered on.

- 7.2 Press the on/off button on the remote/temperature controller so the amber standby light is off.
- 7.3 On the computer board, simultaneously press and hold the INCREASE and DECREASE buttons for five seconds. They are the two lower buttons (Figure 8, page 18).
- 7.4 Release the buttons when the green LED on the control board turns off (Figure 8, page 18). It will turn back on.
- 7.5 Shutoff power to the heater using the on/off switch above the computer board.
- 7.6 After 5 seconds, turn the power on. The heater will be in standby and ready for operation.
8. Contact the technical service department for further assistance if nothing has worked so far. The manifold gas pressure may need to be adjusted.
9. If you are sure that the problem

code as follows:

- 9.1 Turn off the power to the heater using the switch above the computer board.
- 9.2 Turn on power to the heater and proceed to the next steps.
- 9.3 Simultaneously press and hold the INCREASE and DECREASE buttons on the computer board. They are the two lower buttons. See Figure 8.
- 9.4 Release the buttons when the green LED turns off (Figure 8). It will turn back on.
- 9.5 Shutoff power to the heater using the on/off switch above the computer board.
- 9.6 After 5 seconds, turn the power on. The heater will be in standby and ready for operation. If the unit includes a remote controller, press its on/off button to turn the power on.

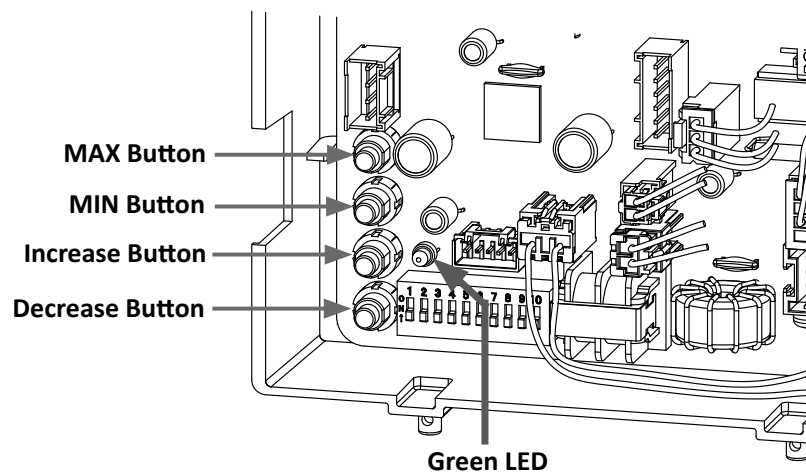

Figure 8.

DIP SWITCH SETTINGS

Use this section to verify DIP switch settings.

Each DIP switch has a specific function as shown in the following tables. Generally, they should not require adjustment.

Verify the function of each DIP switch carefully before changing any settings. If you have questions, contact the technical service department.

Figure 9.

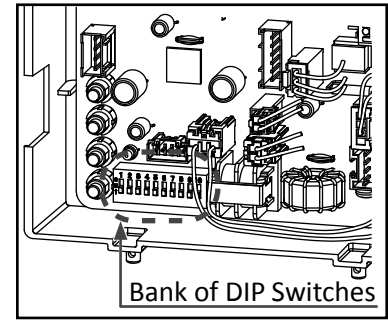

Table 5: DIP Switch Settings

Position switches as indicated by the black squares.

NO.	FUNCTIONS	ON POSITION	OFF POSITION																								
1	Gas type	Propane	Disable																								
2	<div style="display: flex; justify-content: space-around;"> <div style="text-align: center;"> Propane ON: OFF: </div> <div style="text-align: center;"> Natural Gas ON: OFF: </div> </div>	Natural gas	Disable																								
3 4 5	FM+, FM- and Input- (Fan motor speed is increased automatically.) For correct settings, see Table 6, p. 20 and Table 7, p. 21.)	DEFAULT ON: OFF: No. 3: OFF No. 4: OFF No. 5: OFF																									
6 7	Installation settings Set DIP switches shown in the table below depending on the vent length.	Set DIP switches shown in the table below.																									
<table border="1" style="width: 100%; border-collapse: collapse;"> <thead> <tr> <th colspan="4">Venting</th> </tr> <tr> <th>2 inch</th> <th colspan="2">3 inch</th> <th>4 inch</th> </tr> <tr> <th>Single pipe</th> <th>Two-pipe</th> <th>Single pipe</th> <th>Two-pipe & single pipe</th> </tr> </thead> <tbody> <tr> <td>5 to 6.5 ft. ON: OFF: </td> <td>5 to 20 ft. (DEFAULT) ON: OFF: </td> <td>5 to 45 ft. (DEFAULT) ON: OFF: </td> <td>5 to 50 ft. (DEFAULT) ON: OFF: </td> </tr> <tr> <td>N/A</td> <td>21 to 40 ft. ON: OFF: </td> <td>46 to 70 ft. ON: OFF: </td> <td>51 to 100 ft. ON: OFF: </td> </tr> <tr> <td>N/A</td> <td>41 to 70 ft. ON: OFF: </td> <td>N/A</td> <td>N/A</td> </tr> </tbody> </table>		Venting				2 inch	3 inch		4 inch	Single pipe	Two-pipe	Single pipe	Two-pipe & single pipe	5 to 6.5 ft. ON: OFF:	5 to 20 ft. (DEFAULT) ON: OFF:	5 to 45 ft. (DEFAULT) ON: OFF:	5 to 50 ft. (DEFAULT) ON: OFF:	N/A	21 to 40 ft. ON: OFF:	46 to 70 ft. ON: OFF:	51 to 100 ft. ON: OFF:	N/A	41 to 70 ft. ON: OFF:	N/A	N/A	Outdoor model ON: OFF: No. 6 : OFF No. 7 : ON	
Venting																											
2 inch	3 inch		4 inch																								
Single pipe	Two-pipe	Single pipe	Two-pipe & single pipe																								
5 to 6.5 ft. ON: OFF:	5 to 20 ft. (DEFAULT) ON: OFF:	5 to 45 ft. (DEFAULT) ON: OFF:	5 to 50 ft. (DEFAULT) ON: OFF:																								
N/A	21 to 40 ft. ON: OFF:	46 to 70 ft. ON: OFF:	51 to 100 ft. ON: OFF:																								
N/A	41 to 70 ft. ON: OFF:	N/A	N/A																								
8	N/A	N/A	N/A (Default)																								
9	Output temperature settings <div style="text-align: center;"> Temperature set 120°F (49°C) ON: DEFAULT OFF: 140°F (60°C) ON: OFF: </div>	140 °F (60 °C)	120 °F (49 °C) (Default)																								
10*	Deactivation of the exhaust temperature control	Enable	Disable (Default)																								

TROUBLESHOOTING

* **⚠ DANGER!** Do not adjust DIP switch No. 10 without guidance from the technical service department. The only time DIP switch 10 should be set to ON is when your unit is being hooked up to CAT III/IV metal vent with a maximum temp. rating of 480° F. The No. 10 DIP switch deactivates the exhaust temperature control when set to the ON position.

Table 6: Altitude-Specific DIP Switch Settings (Indoor Models)

Indoor models: Propane

ELEVATION	LEVEL	DIPSWITCH SETTINGS			OUTPUT REDUCTION	FAN MOTOR SPEED CHANGE
		NO.3	NO.4	NO.5		
0 to 2,000 ft. (DEFAULT)	0	OFF	OFF	OFF	N/A	N/A
2,000 to 3,000 ft.	1	OFF	ON	OFF	N/A	3 %
3,000 to 5,000 ft.	2*	ON	ON	OFF	-3 %	5 %
	3	OFF	OFF	ON	-5 %	7 %
5,000 to 7,500 ft.	4*	ON	OFF	ON	-7 %	9 %
	5	OFF	ON	ON	-11 %	11 %
7,500 to 10,100 ft.	6	ON	ON	ON	-23.5 %	17.5 %
Special function*		ON	OFF	OFF	N/A	-7%

TROUBLESHOOTING

Indoor models: Natural Gas

ELEVATION	LEVEL	DIPSWITCH SETTINGS			OUTPUT REDUCTION	FAN MOTOR SPEED CHANGE
		NO.3	NO.4	NO.5		
0 to 2,000 ft. (DEFAULT)	0	OFF	OFF	OFF	N/A	N/A
2,000 to 3,000 ft.	1	OFF	ON	OFF	N/A	7%
3,000 to 5,000 ft.	2*	ON	ON	OFF	-4 %	10 %
	3	OFF	OFF	ON	-6 %	15 %
5,000 to 7,500 ft.	4*	ON	OFF	ON	-8 %	17 %
	5	OFF	ON	ON	-11 %	20 %
7,500 to 10,100 ft.	6	ON	ON	ON	-16.5 %	25.5 %
Special function*		ON	OFF	OFF	N/A	-7 %

*The settings are not listed in the Installation manual and owner's guide of 140 (T-H3M) model.

See DIP switch graphics on page 19.

Table 7: Altitude-Specific DIP Switch Settings (Outdoor Models)

Outdoor model 140 (T-H3M): Propane

ELEVATION	LEVEL	DIPSWITCH SETTINGS			OUTPUT REDUCTION	FAN MOTOR SPEED CHANGE
		NO.3	NO.4	NO.5		
0 (DEFAULT) 2,000 ft.	0 (DEFAULT)	OFF	OFF	OFF	N/A	N/A
	1*	OFF	ON	OFF	N/A	6 %
2,000 to 4,000 ft.	2	OFF	OFF	ON	-6 %	10 %
4,000 to 6,000 ft.	3**	ON	OFF	ON	-9 %	14 %
Over 6,000 ft.	4	Consult our Technical Services Department				
Special function*		ON	OFF	OFF	N/A	-7%

*Settings are not listed in the Installation manual and owner's guide of 140 (T-H3M) model.

**If an abnormal sound problem persists even with "Level 3" setting, please contact our Technical Service Department for advice. Note that there are many high risks associated with manually changing manifold pressure.

Outdoor model 140 (T-H3M) : Natural gas

ELEVATION	LEVEL	DIPSWITCH SETTINGS			OUTPUT REDUCTION	FAN MOTOR SPEED CHANGE
		NO.3	NO.4	NO.5		
0 (DEFAULT) 2,000 ft.	0 (DEFAULT)	OFF	OFF	OFF	N/A	N/A
	1*	OFF	ON	OFF	N/A	6 %
2,000 to 4,000 ft.	2	OFF	OFF	ON	-6 %	10 %
4,000 to 6,000 ft.	3**	ON	OFF	ON	-9 %	14 %
Over 6,000 ft.	4	Consult our Technical Services Department				
Special function*		ON	OFF	OFF	N/A	-7%

*Settings are not listed in the Installation manual and owner's guide of 140 (T-H3M) model.

**If an abnormal sound problem persists even with "Level 3" setting, please contact our Technical Service Department for advice. Note that there are many high risks associated with manually changing manifold pressure.

See DIP switch graphics on page 19.

WIRING DIAGRAM

Figure 10. Wiring Schematic and Check Point Locations

W: WHITE BK: BLACK LB: LIGHT BLUE
 R: RED BL: BLUE Y: YELLOW
 G: GREEN O: ORANGE BR: BROWN P: PURPLE

TROUBLESHOOTING

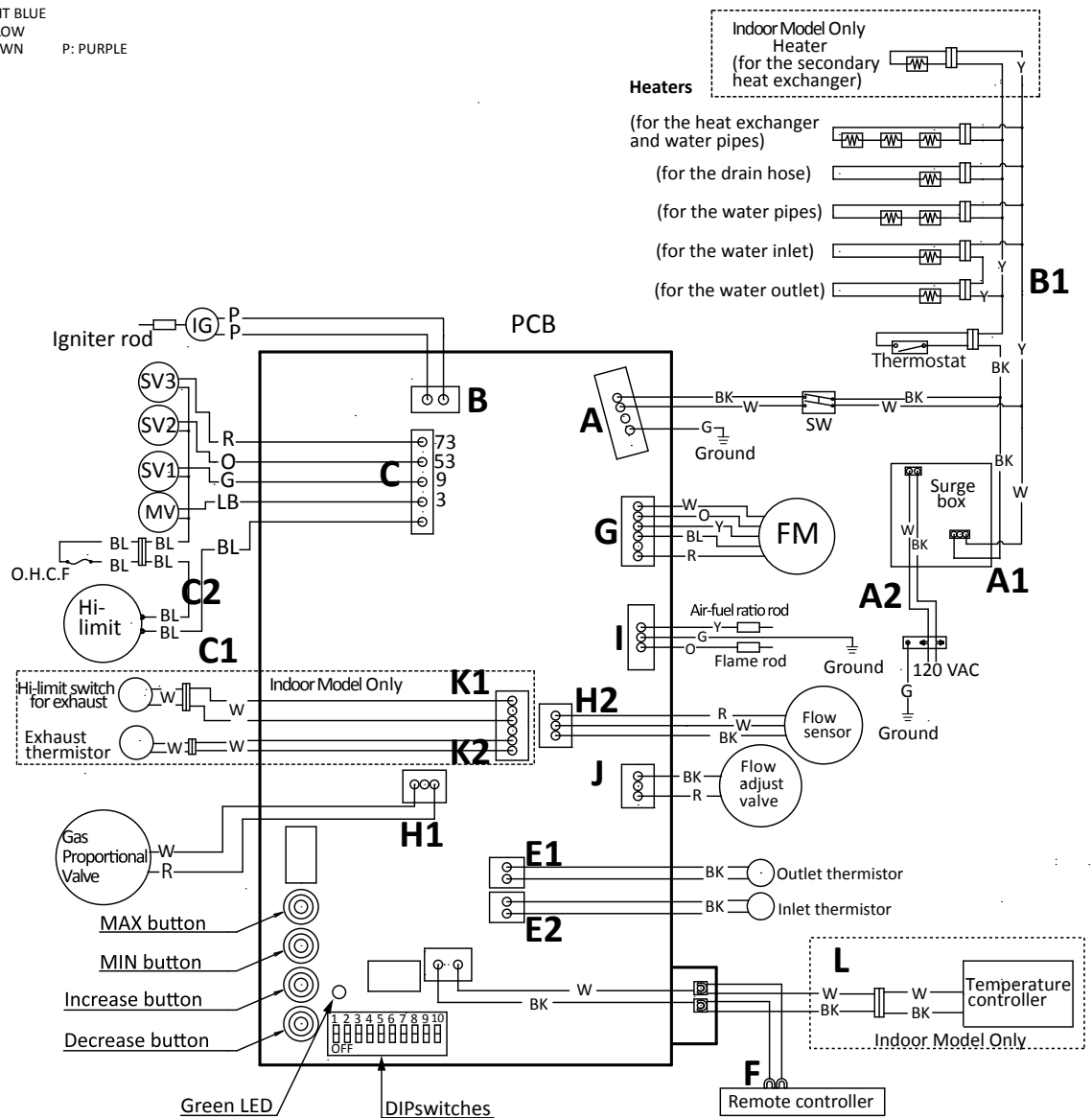

For instructions on how to use the checkpoints shown above, refer to the water heater's maintenance sheet. The maintenance sheet is stored in a pouch on the inside of the water heater's front cover.

Notes:

SERVICE PROCEDURES

Verifying DIP Switch Settings

Incorrect DIP switch settings can cause a 031 error code. To verify your DIP switch settings, see “Dip Switch Settings” on page 19.

For specific DIP switch settings related to vent length or high-altitude installations, refer to the tables that start on page 19. Additional information is provided in the Installation Manual/Owner’s Guide.

Unit Draining and Filter Cleaning

1. Close the manual gas shut off valve.
2. Turn OFF power to the unit, then turn it ON again.
3. Wait 30 seconds, then turn OFF power to the unit again.
4. Close the cold water inlet shutoff valve (Figure 11).
5. Open nearby hot water faucets. When the water flow stops, close all hot water faucets.
6. **IF** the installation includes isolation

valves, follow these sub-steps:

- 6.1 Place a bucket or pan underneath each isolation valve drain port. (There are two: one on the COLD line and one on the HOT line.) See Figure 11.
 - 6.2 Remove the plugs from each isolation valve drain port, then open their valves to drain the water.
 7. Place a bucket or pan under the water filter drain plug (Figure 11).
 8. Remove the water filter drain plug and the water filter.
 9. **Clean the filter.** With a small brush, clean the water filter of any debris which may have accumulated. (See Figure 12). When the filter is clean, reinstall it.
- CAUTION:** Keep the O-rings in place during these steps.
10. Replace all plugs and close all drain valves. **Drain plugs must be hand tightened only.**

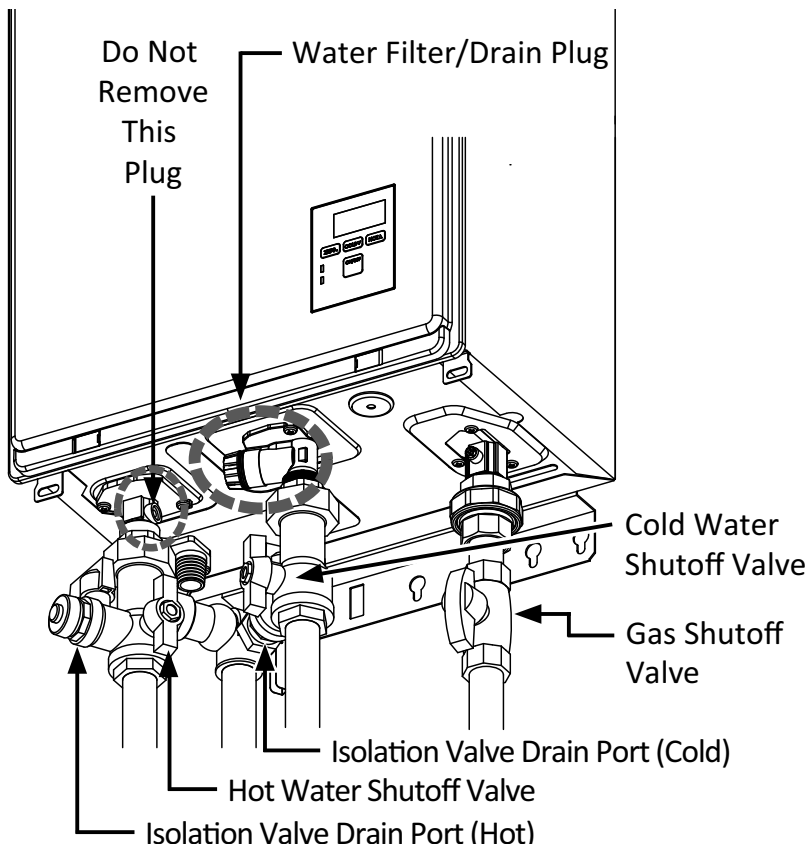

Figure 11. Drain Plugs.

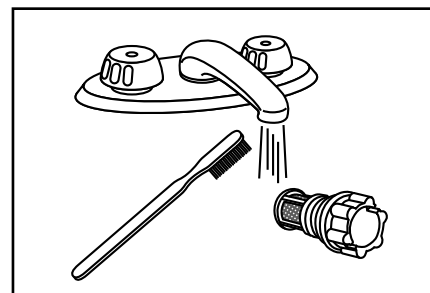

Figure 12. Clean the water filter with a brush.

Checking for a Crossed Connection

1. Turn off cold water supply valve to the water heater. If there are pumps installed in the system for recirculation, ensure that they are turned off.
2. Turn on all hot water fixtures.
 - After a brief time, the water should drain completely.
 - If water continues to run, the fixtures and plumbing system need to be checked.
 - Cold water cross-connections may be related to a recirculation pump application, a defective mixing valve, a bad check valve, a missing check valve in the application, or a cartridge in a single-handle faucet that needs to be replaced.

Checking for a Reversed Connection

1. Close cold water supply at the inlet.
2. Open the pressure-relief valve. It should be installed on the hot outlet side of the unit.
3. If water continues to run through the pressure-relief valve, the system has a reversed connection.

Checking Inlet Gas Pressure/Purging Air from Gas Line

1. Close the manual shut off valve at the gas supply line inlet.
2. Open a faucet. The unit should turn on and the gas in the pipe line should purge. Leave the faucet on to keep the unit running until it shuts down due to lack of gas, then shut the faucet off. Ignore any error codes that may occur at this time.

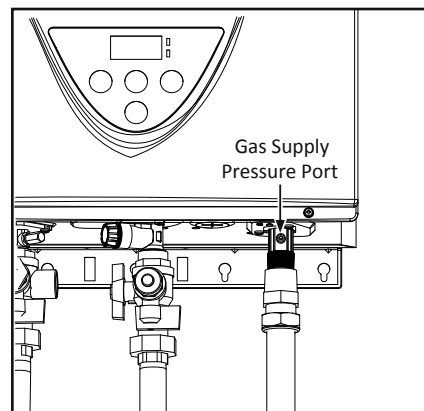

Figure 13.

3. Remove the screw for the pressure port located on the gas inlet. See Figure 13.
4. Connect a manometer to the pressure port.
5. Slowly re-open the manual gas valve. Check to see that there are no gas leaks.
6. Open some of the fixtures that use the highest flow rate to turn on the unit. Ensure that the water heater is running at maximum fire by pressing and holding the "MAX" button on the computer board. (See Figure 8, page 18).
7. Check the inlet gas pressure. Appropriate pressures are as follows:
 - Natural gas: 5 – 10.5 inches W.C.
 - Propane: 8 – 14.0 inches W.C.

Checking and Adjusting the Manifold Gas Pressure

⚠ WARNING! Complete the following procedures **ONLY** if you have been instructed to do so by the Technical Service Department.

Adjusting the manifold pressure can cause unexpected combustion conditions during operation, which can cause a health hazard, damage to the water heater, and/or shorten its lifespan. Therefore, changing the manifold pressure is not recommended unless there are very

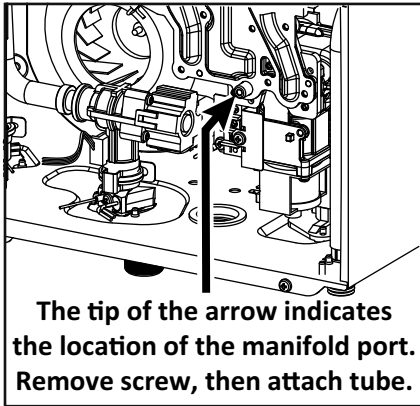

Figure 14.

strong reasons to do so (e.g., high elevation installations).

Checking the Manifold Gas Pressure

1. Verify that the gas supply pressure is within the correct operating range when the heater fires at maximum combustion. (Incorrect gas supply pressure will affect the gas manifold pressure.)
2. Ensure that the unit is not in operation.
3. Remove the screw from the manifold port (Figure 14, p. 26).
4. Connect a manometer to the manifold port using a tube. Ensure that this connection is secure enough to prevent a gas leak.
5. Run water (3.5 GPM or more) to activate operation. It is suggested that you draw a large amount of flow to prevent overheating during maximum burn. If presence of a gas leak is detected, immediately shut off the unit and inspect the tube/manifold connection. Otherwise, proceed to the next step.
6. Check the manifold gas pressures:
 - To check the manifold gas

pressure during maximum combustion, press and hold the "MAX" button on the computer board. (See Figure 8, page 18).

- To check the manifold pressure during minimum combustion, press and hold the "MIN" button on the computer board (Figure 8, page 18).
 - The desired pressures are listed on the "Specifications" page (page 4).
7. When you are finished, deactivate the water heater, remove the manometer tube, and replace the port screw.

However, if the manifold pressures do not match up with those listed on the rating plate, adjust the manifold pressure. To do so, refer to the following procedures.

Adjusting Maximum Manifold Pressure

⚠ WARNING! Complete the following procedure **ONLY** if you have been instructed to do so by the Technical Service Department.

1. Ensure that the water heater is not in operation.
2. Remove the screw from the manifold port (Figure 14).
3. Connect a manometer to the manifold port using a tube. Ensure that this connection is secure enough to prevent gas leak.
4. Run water through the water heater to activate its operation. If presence of a gas leak is detected, immediately shut off the water heater and inspect the tube/manifold connection. Otherwise, proceed to the next step.

5. **During this step, DO NOT press the "Increase" or "Decrease" button for more than two seconds at a time.**

Press and hold down the "MAX" button on the computer board (Figure 8, page 18).

While holding down the "MAX" button, press either the "Increase" or "Decrease" button to increase or decrease the manifold gas pressure, respectively (Figure 8, page 18). Use the manometer to verify that pressure has been set to the desired value.

6. After the gas pressure has been set, deactivate the water heater, remove the manometer tube, and replace the port screw.
7. Verify proper operation.

Adjusting Minimum Manifold Pressure

⚠ WARNING! Complete the following procedure **ONLY** if you have been instructed to do so by the Technical Service Department.

1. Ensure that the water heater is not in operation.
2. Remove the screw from the manifold port of the water heater (Figure 14).
3. Connect a manometer to the manifold port using a tube. Ensure that this connection is secure enough to prevent gas leak.
4. Run water through the water heater to activate its operation. If presence of a gas leak is detected, immediately shut off the water heater and inspect the tube/manifold connection. Otherwise, proceed to the next step.

5. During this step, **DO NOT** press the “Increase” or “Decrease” button for more than two seconds at a time.

Press and hold down the “MIN” button on the computer board. While holding down the “MIN” button, press either the “Increase” or “Decrease” button to increase or decrease the manifold gas pressure, respectively (Figure 8, page 18). Refer to the manometer to verify that pressure has been set to the desired value.

6. After the gas pressure has been set, deactivate the water heater, remove the manometer tube, and replace the port screw.
7. Verify proper operation.

Checking the Overheat Cutoff Fuse (OHCF)

1. Locate the white OHCF which wraps around the heat exchanger. (See Figure 15, page 27.)
2. Find the white clip at the end of the two blue braided wires coming from the OHCF. It is located on the right-hand side of the heater. (Figure 15.)
3. Unplug the connection.
4. Test resistance at the end of the OHCF with an ohmmeter (Figure 15). Resistance should measure 1 ohm or less. If the reading is 1 ohm or less, the OHCF is still intact. Reconnect the plug.

If the resistance exceeds 1 ohm, replace the OHCF (part 319143-

067). Replacing this part will require you to remove the heat exchanger. Follow the “Replacing the Heat Exchanger” instructions which are found in the “Service Procedures” section. Inspect the heat exchanger for any burn marks, hot spots, cracks, etc.

5. Restore power and test the unit. Be very cautious during this step; avoid contact with electrical components and wires.

Checking the Flow Sensor

If the water heater is connected to the water, gas, and power supplies correctly, but the fan motor does not initiate when water flows, then the flow sensor may have failed. (It may not be telling the PC Board to initiate.)

Tools and Materials:

- Flashlight
- Towels

The flow sensor (item 402, p. 70) is located below the water control valve at the cold inlet. (See Figure 16.) Its flow rate is determined by an impeller that spins as fluid runs through it.

To check the flow sensor,

1. Remove the flow sensor as described in “Flow Sensor/Control Valve Removal and Installation,” page 55.
2. Blow into the inlet of the flow sensor. Listen for a spinning impeller. It should spin freely for a few seconds. If it comes to rest abruptly or doesn’t spin at all, it should be inspected for blockage.

If you have a remote, you can check for flow rate by turning on power to the water heater. Push the “Info” button three times. This will display flow if the flow sensor is working properly.

3. Test the flow sensor:
 - 3.1 Reattach the flow sensor wires.
 - 3.2 Turn power to the unit back on. (GAS MUST STILL BE OFF.)
 - 3.3 Blow into the flow sensor. If the fan initiates, the flow sensor successfully read the airflow and should now work properly.

Figure 15. Overheat Cutoff Fuse (OHCF).

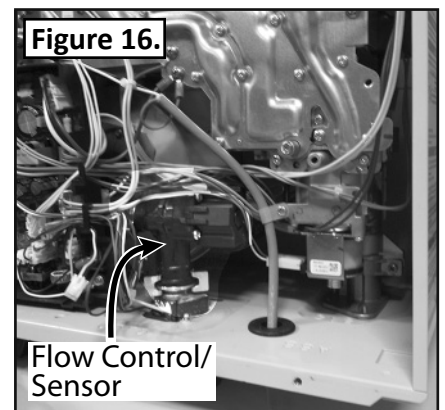
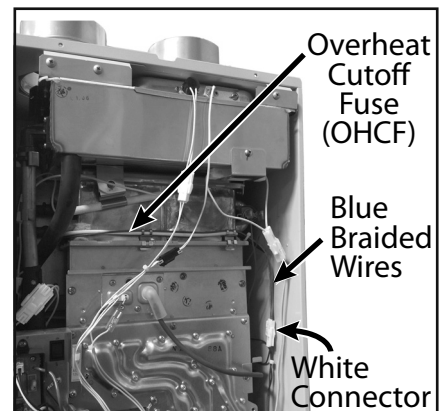

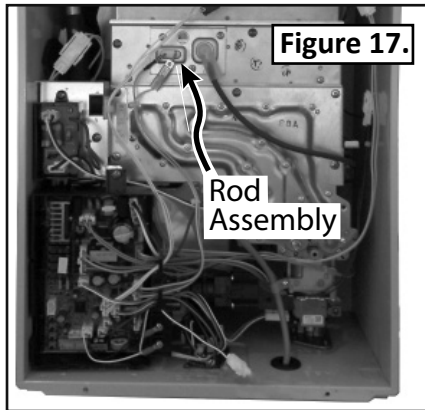

Figure 17.

Also, if you have a remote, you can read the flow rate by pushing the “Info” button three times.

4. Reinstall the flow sensor as described in “Installation” on page 55.

Cleaning the Rod Assembly (Flame Sensor and Air/Fuel Ratio Rod)

Tools:

- Sheet of 100 Grit Sandpaper or other suitable abrasive
- #2 Philips Screw Driver
- Flashlight
- Replacement gasket, part 319143-034.

1. Disconnect power to your unit by either unplugging it from the wall outlet, or by turning it off at the circuit breaker, depending on the setup. Verify that power is off using a volt meter or similar device.
2. Remove the front cover. It is held on by two screws on the top and

two screws on the bottom.

3. Remove the rod assembly as described below. (See Figure 17.)

- 3.1 Locate the yellow and orange wires located in the center of the unit (beside the sight glass).

- 3.1 Disconnect these wires.

NOTE: The yellow wire is locked onto the rod’s conductive spade. To release the spade connector, pinch the **flat** surfaces together at the back of the connector. (Pinch and pull at the same time.)

- 3.2 Remove the three Phillips-head screws holding the panel in place.

- 3.3 Pull the assembly out. **CAUTION!** All pieces are separate. Be careful to not drop or lose the sight glass.

4. Clean the flame sensor and air/fuel ratio rod as described below.

IMPORTANT: Be gentle with the sensor rods while cleaning them because they can bend out of place easily. To function properly, their position relative to the burner must be unaltered.

- 4.1 Clean the **flame sensor** thoroughly with 100 grit sandpaper or other suitable abrasive. Continue until it has a bright finish.

- 4.2 Clean the **air/fuel ratio rod** with 100 grit sandpaper or other suitable abrasive. Continue until it has a bright finish.

5. Inspect the ceramic insulator for chips or cracks. (This ceramic insulator holds the flame sensor and air/fuel ratio rods in place.)

Replace it if any chips or cracks are visible or if either rod moves freely inside the ceramic.

6. Reassemble the unit in reverse order: gasket, rods, and metal

Figure 18.
Descaling the Water Heater

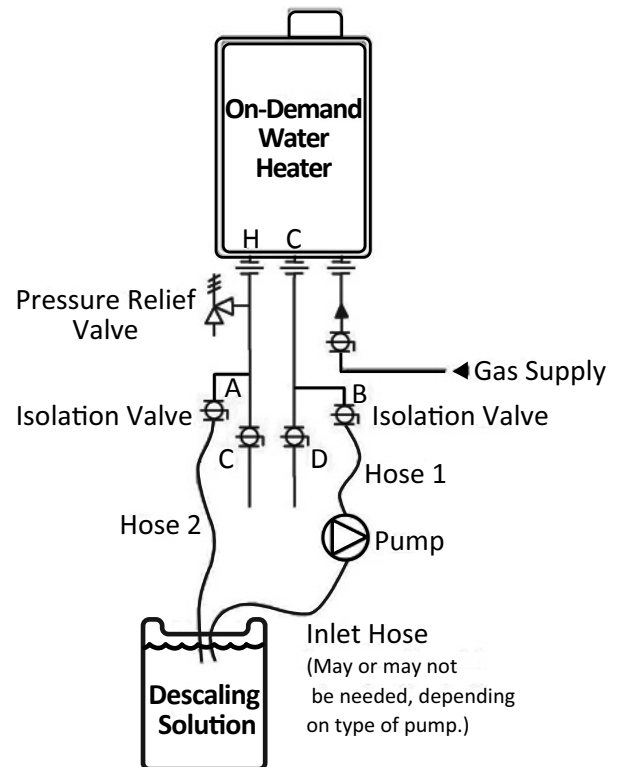

cover. Be sure to connect all 3 wires on the front of the burner. Also, inspect all gaskets to make sure that they are free of debris and are not ripped or torn. If the gaskets are ripped or torn, replace them BEFORE reassembly.

7. Verify proper operation.

Descaling the Unit

Hard water can cause damage to the copper coils inside of the heat exchangers. Heat exchanger failure due to scale buildup, which results from from hard water, is not covered by warranty. In such cases, a scale inhibitor should be installed before the cold water inlet.

Tools and Materials:

- Pump: The pump should provide a minimum of 1 gpm through the water heater.
- 5% white vinegar (food grade)
- Washing machine hoses (2)
- Bucket
- Isolation valves with drain ports (See Figure 18.)

Draining and Hose Connection

To complete this procedure, isolation valves with drain ports are recommended.

1. Isolate the unit by closing the incoming and outgoing water isolation valves (C and D). See Figure 18.
2. Connect hoses.
3. Relieve pressure within the unit by temporarily opening the pressure relief valve.
4. Drain the unit, then connect the

hoses/pump to the drain ports of the isolation valves (A and B). See page 28, Figure 18. See also “Unit Draining and Filter Cleaning,” page 24.

Pump And Descale

1. Fill the bucket with 5 gallons of 5% white vinegar (food grade). The dilution ratio depends on the cleaning/descaling solution that is used. (Follow the manufacturer’s instructions.)
2. If the pump is submersible, place it into the bucket. If it is not submersible, place an inlet hose into the bucket.
3. Open valves A and B. (See Page 28, Figure 18.)
4. Circulate the white vinegar until the water is clear of minerals and debris. This may take up to 45 minutes.

Cleanse the System

Flush the solution out of the heat exchanger with fresh water as described below:

1. Close isolation valve B. (Figure 18.)
2. Open valve D and run fresh water through the unit and drain out of Hose 2 for at least 5 minutes or until all of the solution is removed.
3. Close all valves, relieve pressure from the unit with the pressure relief valve, and clean the inlet water filter with fresh water.
4. Once the unit is flushed and cleansed, replace the water filter, open C and D, then reconnect power to the unit.
5. Set the desired water temperature setting.

6. Restart the water heater as described in its manual. Verify proper operation

Cleaning the Combustion Components

Follow these procedures to clean the fan, burner, flame sensor and air/fuel ratio rod (AFR).

Tools and Materials

- Degreaser in a pump action bottle
- 100 Grit Sandpaper or other suitable abrasive
- #2 Phillips Screwdriver, 8-in long
- Needle-Nosed Pliers
- Duct Tape
- Flashlight
- Air Compressor
- Shop Vacuum
- Towels

IMPORTANT: As you complete the following steps, reinstall the screws after removing each component. Doing so will keep the fasteners organized and will expedite reassembly.

⚠ WARNING!

- Disconnect power by opening the circuit breaker or removing the fuses before installing or servicing.**
- Use a non-contact circuit tester to confirm that power is off before working on or near any electrical parts.**
- Ensure that the gas supply is shut off at the manual gas shutoff valve.**
- Replace the front cover after servicing.**

Before you begin these procedures, consider removing the “Components” section from this manual. It starts on page 35.

This will allow you to lay the loose pages beside this manual for easier reference.

1. Prepare the water heater for service as follows:

- 1.1 Disconnect power to the water heater by unplugging it from the wall outlet or turning it off at the circuit breaker, as appropriate.
- 1.2 Shut off the gas supply at the gas supply line’s manual shutoff valve.
- 1.3 Once the power and gas have been turned off, remove the front panel from the water heater.

2. Remove the computer board from the water heater according to the following steps. (See also Figure 24, page 35.)

- 2.1 Unplug the wire connectors for the high limit switch (item 466, p. 70) and exhaust thermistor (item

Flame Rod Wire Connector:
To remove, pinch flat sides at end with your finger nails, then slide connector off the spade.

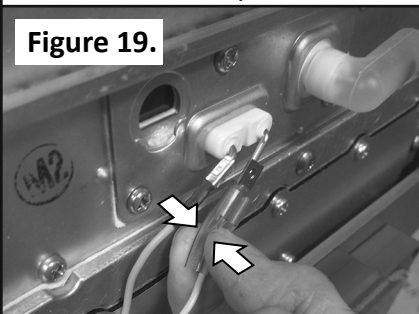

Figure 19.

715, p. 70). See also Figure 24, page 35.

NOTE: Outdoor models will not include an exhaust thermistor. Its location on indoor models is shown on Figure 24, page 35.

- 2.2 Unclip the high limit wires from the side of the fuse box assembly. The wires are secured by a nylon clamp (item 712, p. 68). See also Figure 24, page 35.
- 2.3 Remove the following from the front of the burner:
 - Flame rod wire (orange): Item 708 (page 69); See also page 35, Figure 24.
 - Air-fuel ratio rod/AFR wire (yellow): **See Figure 19.** See also page 35, Figure 24.
 - Igniter rod wire (black): Item 709, page 69; See also page 35, Figure 24.
- 2.4 Remove the screw that secures the computer board assembly. (See Figure 24, p. 35.) **Do not remove connectors from the circuit board.**
- 2.5 Remove the computer board assembly.

3. Unplug both white connectors above the fuse box (yellow wires), then move the fuse box away from the work area.

4. Remove the Gas Valve and Manifold Plate Assembly:

- 4.1 Remove the screws that secure the green ground wires to the manifold plate.
- 4.2 Remove the screws that secure the manifold plate (Figure 24, page 35).

IMPORTANT: Remove only the screws along the outside edges of the manifold plate. See Figure 21, page 31.

- **DO NOT remove the screws securing the manifold plate to the gas valve.**
- **DO NOT remove the screws along the interior of the manifold plate.**

- 4.3 Remove the screw on the left side of the gas valve that secures the power cord.
- 4.4 Disconnect the clear air tube off the left side of the gas valve. **(If necessary, see Figure 37, page 42)**
- 4.5 Disconnect the connector on the right side (blue wires) which goes to the overheat cutoff fuse (Figure 24, page 35).

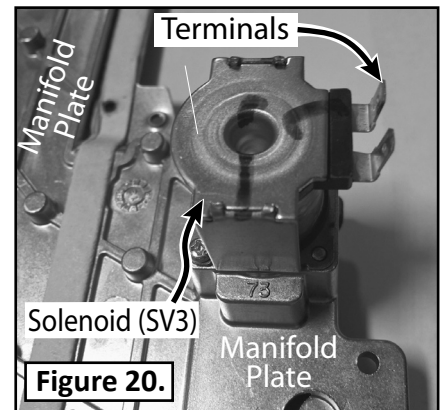

Figure 20.

- 4.6 Remove the screw securing the gas valve to the gas connection. The screw is located at the bottom, right-hand side of the gas valve; see Figure 24, page 35.
- 4.7 Lift the manifold plate/ gas valve assembly upward to remove it from the gas inlet connection. (The gas valve and manifold are still connected together.)

You may need to twist the gas valve/manifold assembly slightly.

Manifold Screws:

- **DO NOT** remove the screws shown below (indicated by white, crossed-out circles).
- Remove the remaining screws along the outside edge (except as indicated).

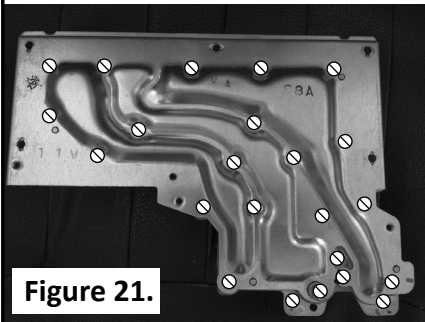

Figure 21.

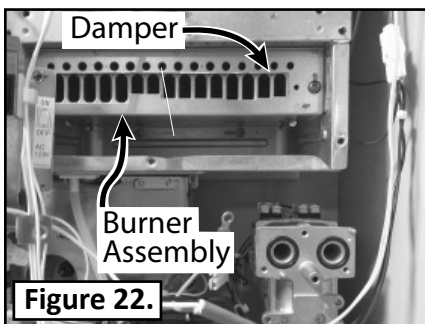

Figure 22.

- 4.8 Unplug the wire connectors at the solenoid valve (SV3); the solenoid valve is attached to the corner of the manifold plate. See Figure 20.
- 4.9 Unplug the proportional gas valve connector (item 711, page 69).
- 4.10 Disconnect the solenoid connectors (Item 707, p. 69) from the gas valve. (There are three connectors.)
- 4.11 Inspect the gaskets on the manifold plate for any tears. If compromised, replace with part number 319143-044 (item 113) and/or 319143-045 (item 114). See page 69.
- 4.12 Inspect the o-ring (item 151, p. 69) and gas inlet ring (item 119, p. 69) on the gas connection for cuts or breaks.

If damaged, replace with part number 319143-057 (item 151) and/or 319143-049 (item 119). See page 69.

5. Remove the burner assembly according to the following steps. (See Figure 22.)

- 5.1 Remove the pan-head Phillips screws holding the burner to the combustion chamber. There are several at the top of the burner and two more at the bottom (toward back of combustion chamber). If the screws at the bottom are difficult to remove, lift the burner while turning the screws.

- 5.2 Note the orientation of the damper, then remove the damper (item 112, p. 69). See Figure 22.
- 5.3 Remove the burner assembly as described below:
 - 5.3.1 Grasp an oval air vent on the front of the burner (at the edge on either side).
 - 5.3.2 Pull firmly while pushing on the bottom of the combustion chamber to provide leverage.
 - 5.3.3 Repeat on the opposite side to loosen the assembly.
 - 5.3.4 Pull from the center. It should slide out easily.
- 5.4 Inspect the gasket. Minor surface tears are acceptable. If the gasket shows major separations, replace the gasket before the unit is returned to service.

6. Clean the burner:

- Use a safe degreaser.
 - Protect the burner gasket from direct water pressure. If the gasket is damaged in any way, contact technical service for further assistance.
- 6.1 Saturate the burner with the cleaning solution (from top, down through slots, and openings in front of burner). Continue until burner is completely wet.
 - 6.2 Wait for five minutes.
 - 6.3 Set the burner in a sink in its normal, upright position and wash the burner with a high flow of water. Ensure that the water flows down

into the slots, starting at the back and moving forward.

Make sure that no contact is made with the gasket; protect it from direct water pressure. Rinse thoroughly.

- 6.4 Clear excessive water from the burner with compressed air.
- 6.5 Inspect the gasket. Minor surface tears are acceptable. If the gasket shows major separations, replace the gasket before the unit is returned to service.

7. Clean the fan:

- 7.1 Disconnect and remove the fan from the combustion chamber as follows:
- 7.1.1 Remove the clear air tube from the bottom of the combustion chamber. If needed, refer to Figure 33, page 41.
- 7.1.2 Remove the 2 Phillips/hex head screws pointing down from the fan using an 8" long, #2 Phillips head screw driver. There are 2 holes in the case directly below the screws to put the screw driver through.

- 7.1.3 Slide the fan toward you to remove it from the rear slots that hold it in place. Remove the fan.

- 7.2 Blow compressed air into the fan. The fan will rotate and dust will fly out of the fan housing.

NOTE: You will reassemble these items in reverse order at the end of this procedure.

8. Clean the heat exchanger:

- 8.1 If you have a DV model, remove the exhaust venting from the top of the unit.
- 8.2 Place towels as follows:
- Place one towel at the bottom of the combustion chamber so that it covers the fan discharge opening (fan port).
 - Drape a second towel so that it covers the square opening of the combustion chamber (to prevent the entry of airborne debris)

- 8.3 Use the air compressor to blow air down through the top of the heat exchanger and through the vent collar.

At the same time vacuum the dirt from the combustion chamber. Continue until all dirt has been removed.

- 8.4 Inspect the heat exchanger. If there is a white, solid, crusty buildup in the heat exchanger, please contact technical service for instruction.

NOTICE: During the next step, be gentle with the sensor rods when cleaning them. They will bend out of place easily. If they are bent out of place, the operation of the water heater could be affected.

9. Clean the flame sensor and air/fuel ratio rod (AFR) with sand paper or other appropriate abrasive, bringing it to a bright finish.

Continued...

10. Reassemble all items in reverse order. Use this checklist:

- If necessary, refer to the exploded assembly views which start on page 67.
- Inspect all gaskets.
- Ensure that the black O-rings and mesh filter on the gas valve inlet are not pinched or otherwise damaged during reinstallation.
- ALL screws must be hand tightened only, especially around the gas valve inlet.
- Reconnect the plastic tube from gas valve to the bottom of the combustion chamber.
- Reinstall the fan.
- Verify that all components are reattached and are secure.

NOTICE:

- Ensure that all wire connectors have been reconnected.
- Some connectors are not keyed. When they are not, align the printed number on the wire to the corresponding number that is stamped on the solenoid body. See Figure 23.

For example, if “73” is printed on a wire, its pin should plug into the side of the connector that has the number “73” stamped closest to it.

- All connectors with **yellow** wire go to the same circuit. They may be reconnected in any order.

Figure 23.

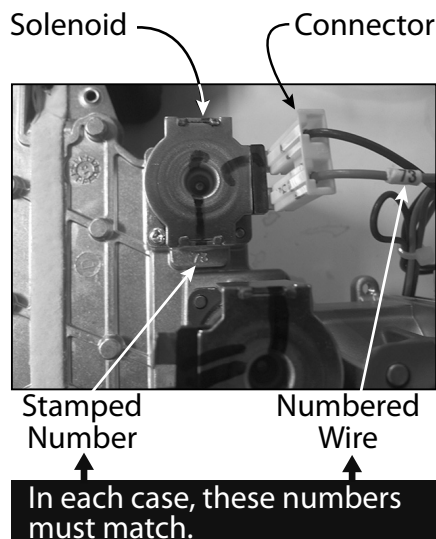

This page is intentionally left blank. The Maintenance section begins on the next page.

MAINTENANCE

Indoor Model:

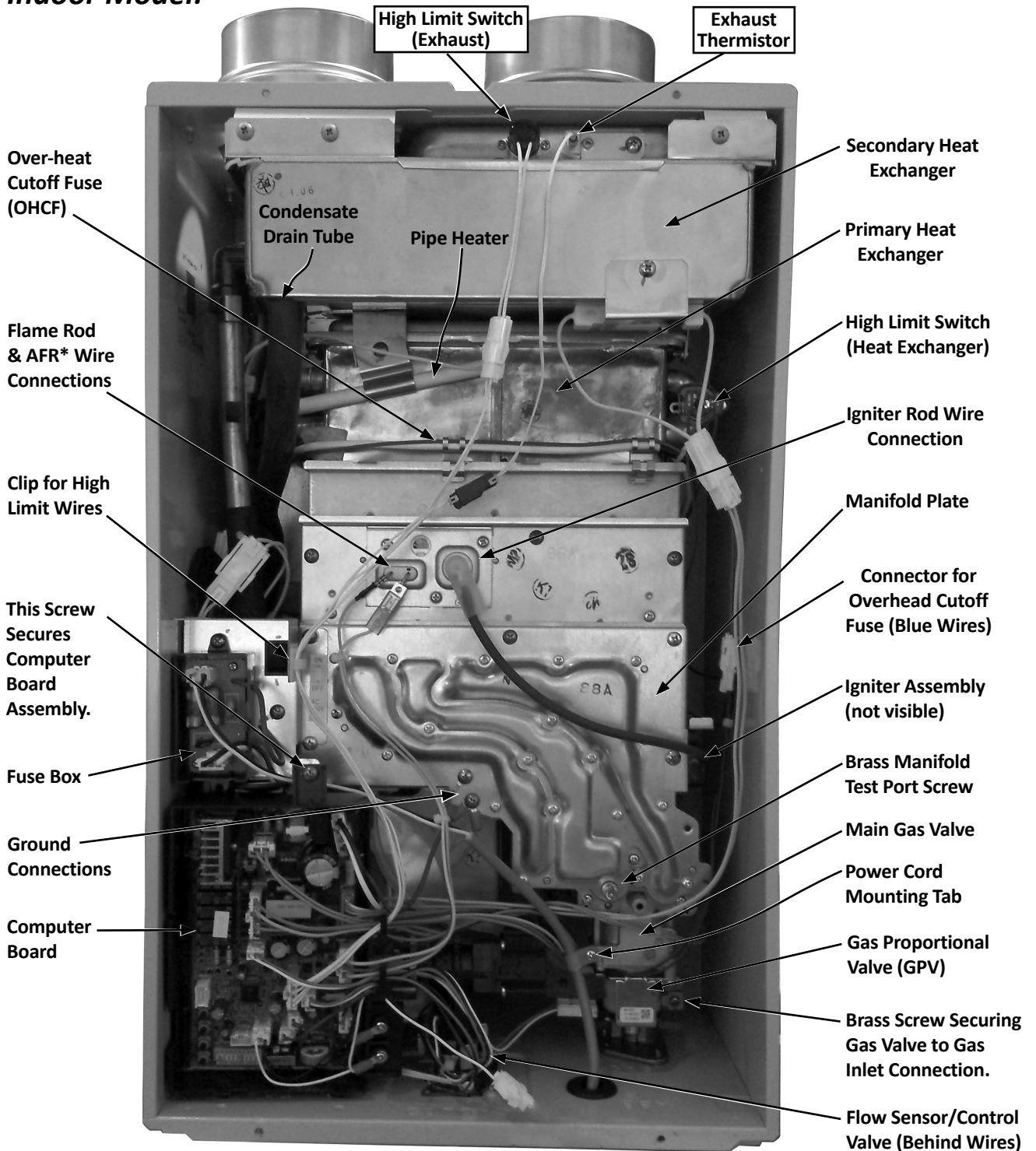

Figure 24.

* Air/Fuel Ratio Rod

See also "Component Diagrams/Item Numbers" which starts on page 67.

MAINTENANCE

Outdoor Model:

MAINTENANCE

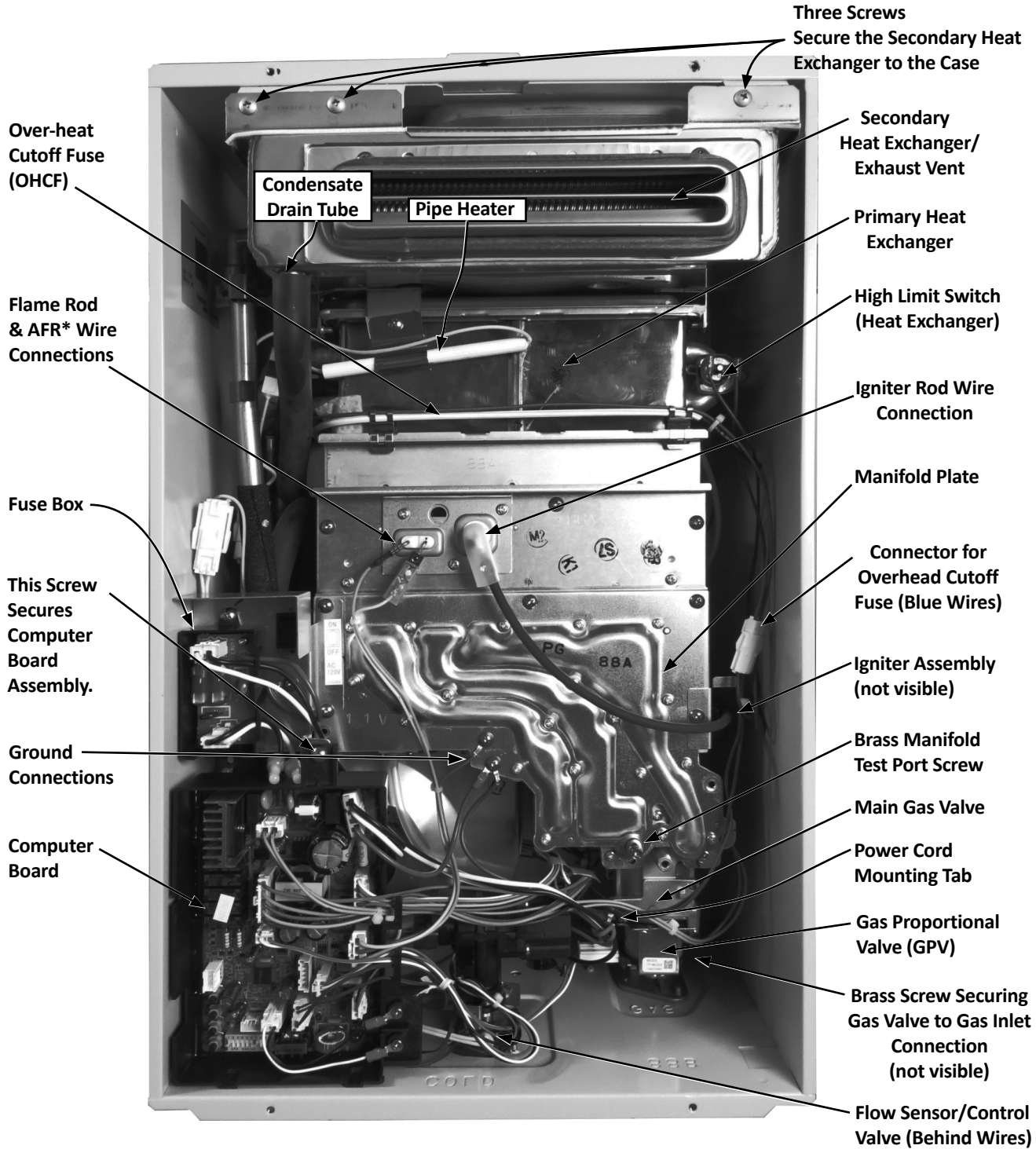

Figure 25.

* Air/Fuel Ratio Rod
 See also "Component Diagrams/Item Numbers" which starts on page 67.



Replacing the Heat Exchanger (Indoor Models)

Tools:

#2 Phillips Screw Driver, 8" long
(a magnetic tip is helpful)

⚠ WARNING!

- **Disconnect power by opening the circuit breaker or removing the fuses before installing or servicing.**
- **Use a non-contact circuit tester to confirm that power is off before working on or near any electrical parts.**
- **Ensure that the gas supply is shut off at the manual gas shutoff valve.**
- **Replace the front cover after servicing.**

Consider removing the following sections from this manual for easy reference:

- “Component Diagrams/Item Numbers” (starting on page 67).
- Figure 24, page 35, which shows the location of basic components.

This will allow you to lay the loose pages beside this manual for easier reference.

Also, screw sizes vary. We recommend bagging and labeling screws as you remove them, or reinstall them in their proper places as you proceed with disassembly. This will make reassembly easier.

Removing Heat Exchanger Components (Indoor Models)

1. Shut the unit down as follows:

- 1.1 Shut Off power and gas supply as follows:
 - 1.1.1 Shut off Power by disconnecting the power cord or shutting off the power disconnect.
 - 1.1.2 Shut off the gas supply to the water heater at the manual gas shutoff valve.
- 1.2 Drain the water from the heater as follows:
 - 1.2.1 Close the shutoff valves on the hot and cold side of the heater.
 - 1.2.2 IF isolation valves are installed: open up the drain ports.
 - 1.2.3 IF isolation valves are not installed: remove the filter (item 405, page 70) and open the pressure relief valve.

2. Remove the Temperature Controller (item 721, page 67) by disconnecting the white connectors that go to the computer board.

3. Remove the computer board as follows (item 701, page 68; see also Figure 24, page 35):

CAUTION:

- During the next step, consider taking a digital photo to aid in reassembly.
- Do not touch the circuit board components. Doing so may

cause damage by electrostatic discharge.

- 3.1 Disconnect all wire connectors from the computer board.
- 3.2 Remove the screw at the top of the computer board assembly, then remove the board (Figure 24, p. 35).

4. Remove the fuse box assembly (items 703, 120; page 68):

- 4.1 Disconnect the connector at the top port which comes from the main power supply.
- 4.2 Disconnect the freeze protection heater wires. There are 6 sets of white connectors with yellow wires (two above the assembly, three below the assembly, and one below the secondary heat exchanger on the right side).
- 4.3 Remove the screw that secures the fuse box and lift the fuse box away.

5. Remove the flow sensor/control valve (item 402, page 70; see also Figure 24, page 35):

- 5.1 Remove fasteners 16A and 14-22 (items 458 and 459, page 70).
- 5.2 Pull the cold connection tube (item 462, p. 70) from the outlet of the flow sensor/control valve and lift the valve off of the inlet connection. You may have to twist the valve off of the inlet connection.

6. Remove the cold connection tube (item 462, page 70) as follows:

6.1 Disconnect fastener 14-22 (item 458, page 70).

6.2 Remove two heaters and clips (located at top and bottom of tube):

- Items 413 & 451, p. 70.
- Items 414 & 451, p. 70.

See also Figure 28.

6.3 Slide the cold connection tube downward and remove it.

7. Remove the igniter assembly:

7.1 Remove the screw that secures the igniter assembly (See Figure 24, page 35.)

7.2 Disconnect the igniter wire at the igniter rod wire connection (Figure 24, page 35).

8. Disconnect the blue wires from the high limit switch. See “High Limit Switch (Heat Exchanger),” Figure 24, page 35.

The wires are locked onto the connectors. Pinch the flat sides on each connector to release it.

Flame Rod Wire Connector:
To remove, pinch flat sides at end with your finger nails, then slide connector off the spade.

Figure 26.

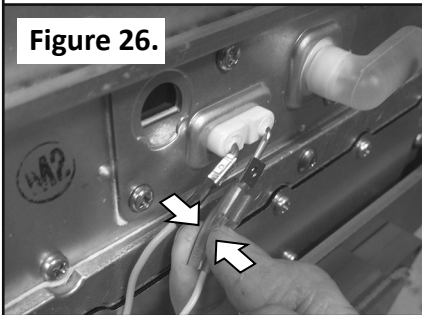

9. Remove the Gas Valve and Manifold Plate Assembly:

9.1 Unplug wire connectors from the air/fuel ratio rod (AFR), flame rod, and igniter. See Figure 26.

9.1 Remove the screws that secure the green ground wires to the manifold plate.

9.2 Remove the screws that secure the manifold plate (Figure 24, page 35).

IMPORTANT: Remove only the screws along the outside edges of the manifold plate. See Figure 27.

- **DO NOT** remove the screws securing the manifold plate to the gas valve.

- **DO NOT** remove the screws along the interior of the manifold plate.

9.3 Remove the screw on the left side of the gas valve that secures the power cord.

9.4 Disconnect the air tube off the left side of the gas valve. (See page 42, Figure 37.)

9.5 Disconnect the connector on the right side (blue wires) which goes to the overheat cutoff fuse (Figure 24, page 35).

9.6 Remove the brass screw securing the gas valve to the gas connection. The screw is located at the bottom, right-hand side of the gas valve; see Figure 24, page 35.

9.7 Lift the manifold plate/gas valve assembly upward to remove it from the gas

inlet connection. (The gas valve and manifold are still connected together.)

You may need to twist the gas valve/manifold assembly slightly.

9.8 Unplug the wire connectors at the solenoid valve (SV3); the solenoid valve is attached to the corner of the manifold plate. If necessary, see Figure 20, page 30.

9.9 Disconnect the solenoid connectors (Item 707, p. 69) from the gas valve. (There are three connectors.)

9.10 Disconnect the proportional gas valve connector (item 711, p. 69) from the assembly.

9.11 Inspect the gaskets on the manifold plate for any tears. If compromised, replace with

Manifold Screws:

- **DO NOT** remove the screws shown below (indicated by white, crossed-out circles).
- **Remove the remaining screws along the outside edge (except as indicated).**

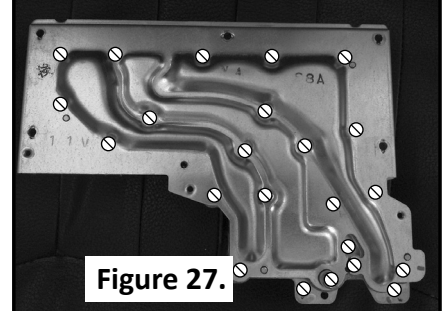

Figure 27.

part number 319143-044 (item 113) and/or 319143-045 (item 114). See page 69.

- 9.12 Inspect the o-ring (item 151, p. 69) and gas inlet ring (item 119, p. 69) on the gas connection for cuts or breaks.

If damaged, replace with part number 319143-057 (item 151) and/or 319143-049 (item 119). See page 69.

10. Disconnect and remove the fan from the combustion chamber as follows:

- 10.1 Remove the clear air tube from the bottom of the combustion chamber. If needed, refer to Figure 33, page 41.
- 10.1 Remove the 2 Phillips/hex head screws pointing down from the fan using an 8" long, #2 Phillips head screw

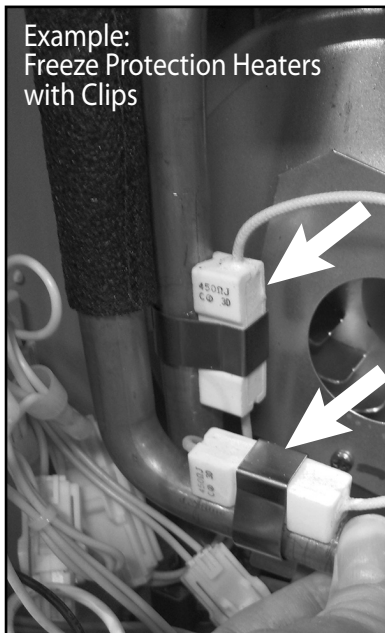

Figure 28.

driver. There are 2 holes in the case directly below the screws to put the screw driver through.

- 10.2 Slide the fan toward you to remove it from the rear slots that hold it in place. Remove the fan.

11. Remove the burner from the combustion chamber:

- 11.1 Remove two screws below the burner, at the back (Figure 29).
- 11.2 Remove three screws across the front of the burner. See Figure 29. Do not remove the screws around the flame sensor/AFR and igniter rods.
- 11.3 Slide the burner out toward you. You may need to use a small set of pliers to loosen the burner on the sides and then pull from the middle portion of the inlet holes.

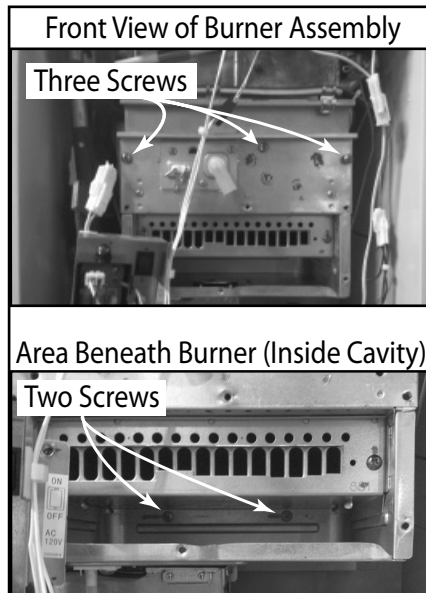

Figure 29.

- 11.4 Check the gaskets on the burner for any tears. If there are, replace the gasket with part number 319143-032.

12. Disconnect and remove the following items:

- 12.1 Disconnect the condensate drain line (item 415, page 70) from the secondary heat exchanger assembly by pulling down. Do not remove the drain line from the outlet connection at the bottom of the cabinet.
- 12.2 Remove fastener 16-25 (item 460, page 70) from the outlet tubing and outlet water connection.
- 12.3 Slide the outlet tube up and out of the outlet water connection. Remove the tube.
- 12.4 Disconnect the venting from the exhaust flue.
- 12.5 Remove the three screws at the top of the secondary heat exchanger that are securing it to the case. Refer to Figure 30.

Three Screws Securing the Secondary Heat Exchanger

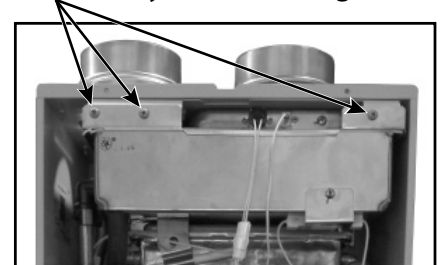
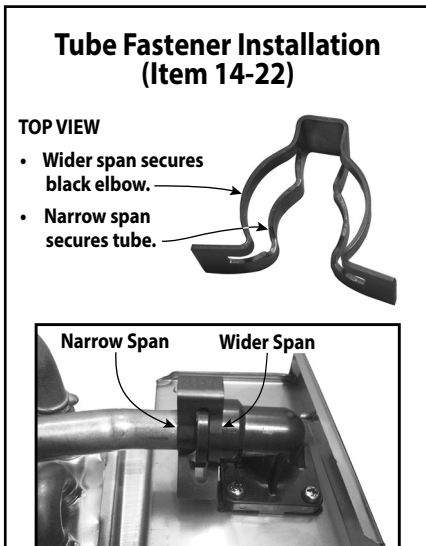
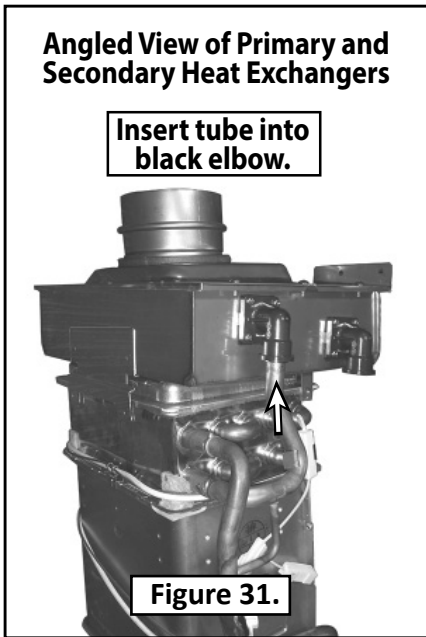

Figure 30.

13. Follow these steps to remove the heat exchangers:

- 13.1 Slide the heat exchangers down while gradually angling the bottom toward you.
- 13.2 Separate the primary and secondary heat exchangers as follows:



13.2.1 Remove fastener 14-22 (item 458, p. 70) from the tube on the left-hand side. (This tube connects the primary heat exchanger to the secondary heat exchanger.)

13.2.2 Remove the four screws that connect the primary and secondary heat exchangers (Figure 34).

13.3 IF you are replacing the primary heat exchanger assembly, go to “Preparing the New Primary Heat Exchanger for Installation (Indoor Models).”

IF you are replacing the secondary heat exchanger assembly Go to “Preparing the New SECONDARY Heat Exchanger for Installation (Indoor Models).”

Preparing the New PRIMARY Heat Exchanger for Installation (Indoor Models)

The primary heat exchanger is the same assembly for both indoor and outdoor models. It comes with:

- A combustion chamber attached to the bottom of the heat exchanger (See “Combustion Chamber,” page 70)
- A plate attached at the top with a gasket surrounding the flue gas connection to the secondary heat exchanger. See “Heat Exchanger (Primary)” on page 70.

1. Make sure the gasket on top of the primary heat exchanger is not compromised. If it is, contact technical support.

2. Remove the following items from the primary heat exchanger and INSTALL THEM IN THE SAME LOCATIONS ON THE NEW HEAT EXCHANGER:

- High limit switch on the right side (item 411, p. 70).
- Over-heat Cutoff Fuse (OHCF) (item 412, p. 70) and its five clips. (Four clips are attached to the primary heat exchanger and one is attached to the outlet tube.) See also Figure 24, page 35.
- Air tube and its connector/nipple on the bottom of the combustion chamber. (See page 41, Figure 33.)
- Two (2) freeze protection heaters and clips; one is located on the outlet tube near the bottom and the other is located on the connection tube from the secondary heat exchanger. (See items 413 and 414 on page 70. See also page 39, Figure 28.)
- O-Rings on the connection tubes: Item 455 (p. 70) is attached to the connection tube from the secondary heat exchanger. Item 457 (p. 70) is attached where the outlet water tube connects to the outlet water connection. (See connection points “A” and “C,” p. 70).

CAUTION: these O-rings are different sizes, so label them and keep them separated.

3. Complete the steps in the next section: “Preparing the New SECONDARY Heat Exchanger for Installation (Indoor Models).”

Preparing the New SECONDARY Heat Exchanger for Installation (Indoor Models)

NOTICE: Assembly of the secondary heat exchanger is different for the indoor and outdoor models.

1. Remove the following items from the secondary heat exchanger, then **INSTALL THEM IN THE SAME LOCATIONS ON THE NEW HEAT EXCHANGER:**

- Flue gasket (item 154, p. 70) that is located around the exhaust flue.
- Exhaust high limit switch (item 466, p. 70): remove the two (2) screws that are holding it in place.
- Exhaust thermistor and gasket (items 464 ,465, and 715 on p. 70): one screw holds the plate in place (item 053, p. 70).
- Two (2) freeze protection heaters: one is shaped as a long rod (item 413, p. 70) and located on the front, left-hand side of the assembly. The other is located on the front, right-hand side of the assembly (item 418, p. 70).

2. Complete the steps in “Installing the Heat Exchanger (Indoor Models).”

Installing the Heat Exchanger (Indoor Models)

1. Connect the primary and secondary heat exchangers, making sure that the flange on top of the primary heat exchanger (male connector) goes into the connection on the bottom of the secondary heat exchanger. The tube from the primary heater will insert into the back elbow on the secondary heat exchanger (Figure 31, page 40).
2. Make sure that the screw holes on the sides and back line up properly. Insert and hand-tighten all four (4) mounting screws. See Figure 34, page 41.
3. Attach fastener 14-22 (item 458, page 70) where the connection tube from the primary heat exchanger and the back elbow on the secondary heat exchanger meet. See Figure 32, page 40.

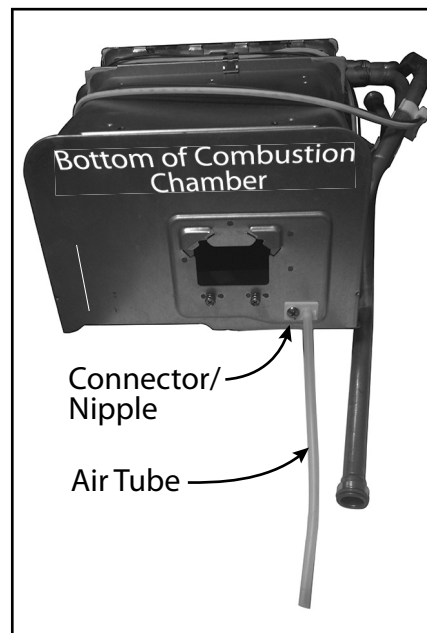

Figure 33.

(“14-22” is marked on the end of this clip; all such clips are marked on the end in the same manner.)

4. Install the heat exchanger assembly into the case, making sure that the flue gasket (item 154, p. 70) is on the inside of the case.
5. Insert and hand tighten three (3) screws as shown in Figure 30, page 39. This will secure the heat exchanger assembly to the heater case.
6. Install the burner into the combustion chamber. (See page 70.) There are grooves on the sides of the combustion chamber; the bottom of the burner will slide along the grooves.
 - 6.1 Insert and hand tighten two (2) screws below the burner, at the back. (See Figure 29, p. 39.) These screws will secure to the back of the

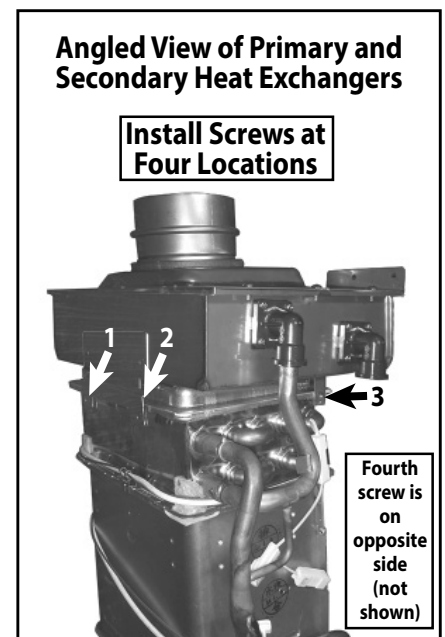
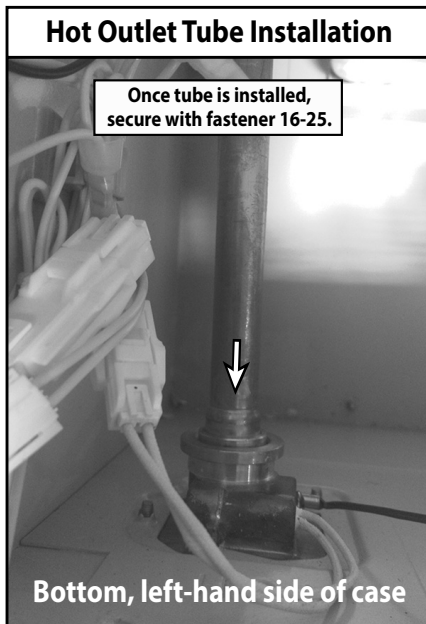

Figure 34.

cabinet. You may need to push the assembly up some in order to line up the holes.

- 6.2 Insert and hand tighten three (3) screws along the top, front portion of the burner (Figure 29, p. 39).
- 7. **Insert the outlet tubing into the water outlet connection, making sure that the brass ring on the tube goes all the way in and is flush with the top of the outlet connection (Figure 35). Install fastener 16-25 (stamped on the end of the fastener). See also item 460 on page 70.**
- 8. **Attach the top of the condensate drain tube to the port on the bottom of the secondary heat exchanger. (See Item 415 and connection point "E" on p. 70.)**

Figure 35.



9. Install the fan with the air inlet facing toward the front as follows:

- 9.1 Slide the fan discharge into the slots on the bottom of the combustion chamber.
- 9.2 Line up the holes, then insert and hand-tighten two (2) hex head screws (item 54). See page 69.

10. Install the gas valve/manifold assembly (item 102, p. 69) as described below:

- 10.1 Make sure the screen on the inlet to the gas valve is still in place.
- 10.2 Attach the wire connectors to each of the solenoid valves.
 - Each connector has a dark blue wire, except for the proportional valve. The other wire colors will vary.
 - Each set of wires has a tag with a number on it. Each solenoid valve has

a number stamped next to it. During installation, each wire number must match its solenoid valve number. See Figure 36.

- Install each connector to the solenoid valve with the matching number.
- The proportional valve does not have a number and is located at the bottom of the assembly. Wire colors: red & white.

- 10.3 Slide the gas valve/manifold plate assembly onto the gas inlet connection. You may need to rotate the gas valve while sliding down for an easier fit. The tab on the gas valve connection should line up behind the tab on the gas inlet connection.
- 10.4 Secure the gas valve to the gas inlet by installing the brass screw (with washer) through both tabs at the

Figure 36. Gas Valve Wiring

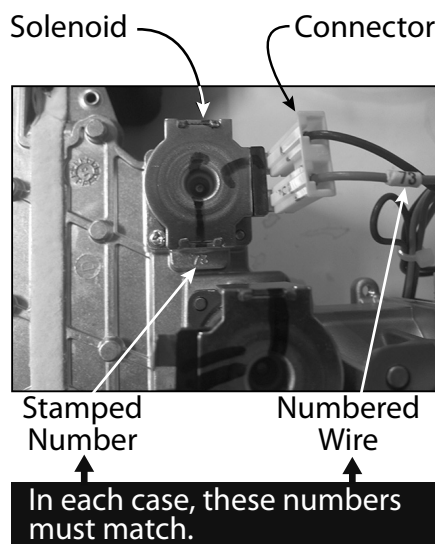
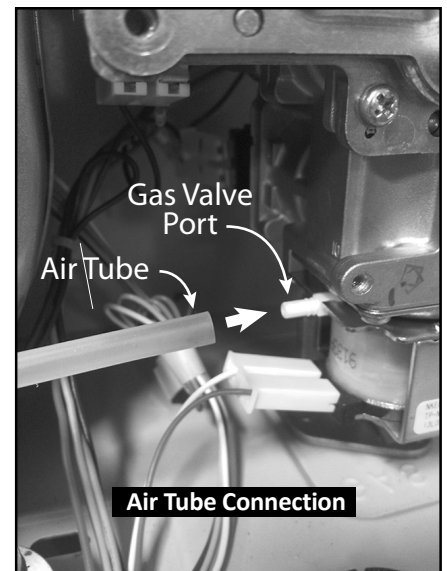

Figure 37.



connection. **Hand-tighten only.** See Figure 24, page 35.

- 10.5 Attach the air tube from the bottom of the combustion chamber to the port on the left side of the gas valve. (See page 42, Figure 37.)
- 10.6 Secure the power cord to the gas valve as shown in Figure 24 on page 35. (See the “Power Cord Mounting Tab” callout.) **Hand-tighten only.**
 - Use the mounting tab and the M4X10 screw.
 - The mounting hole is located on the left side of the gas valve.
- 10.7 Line up the manifold plate with the holes on the burner and combustion box. Insert and hand tighten the top center screw on the manifold plate. (See “Manifold Plate,” page 35.)
- 10.8 Hand tighten the remaining manifold plate screws. Do not overtighten.

NOTE: Leave the fuse box mounting holes open (left side of plate). The fuse box will be mounted later.

- 11. **Install the igniter assembly to the lower, right-hand corner of the manifold plate.** (See “Igniter Assembly” and “Igniter Rod Wire Connection” on page 35; see also item 709 on page 69.)
 - 11.1 Insert and hand tighten the screw.

- 11.2 Slide the black igniter wire onto the igniter rod. See “Igniter Rod Wire Connection” in Figure 24, page 35.

12. Install the flow sensor/control valve (item 402, p. 70) and cold connection tube (item 462, p. 70) as follows:

- 12.1 Insert the long, straight end of the cold connection tube into the elbow on the secondary heat exchanger. See connection point “B” on page 70 (shown in two places).
- 12.2 Install the flow sensor/control valve onto the inlet water connection (Figure 24, page 35).
- 12.3 Insert the end of the cold connection tube into the outlet of the flow sensor/control valve. See connection point “D” on page 70 (shown in two places).
- 12.4 Install the fasteners:
 - One 16A fastener. See item 459 on p. 70, which secures the inlet of the flow sensor/control valve to the inlet water connection. “16A” is marked on the end of this clip.

Install the clip as shown in Figure 38.

Figure 38.

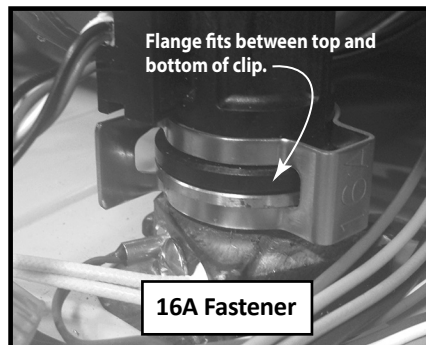

- Two 14-22 fasteners. (“14-22” is marked on the end of each clip.)

See both instances of item 458 on page 70. These fasteners secure the cold connection tube at each end. Install as described in Figure 32, page 40.

See also connection points “B” and “D” on page 70. The cold connection tube’s brass rings must be fully inserted at each connection point.

- 12.5 Verify that all of the fasteners on the water tubing are installed properly.
- 12.6 Install the cold water inlet filter. Refer to the water heater’s manual, if needed.
- 12.7 Test for leaks by slightly opening the water supply to the water heater. Check the water tube connections for any drips or leaks. If any appear, turn off the water, drain the water heater, dry the components that got wet, and fix the leak.

13. Verify that the following pipe heaters are installed. See the pipe heaters on page 70: item 413 (three instances), item 414 (two instances), and item 418 (one instance).

- 13.1 Install the long pipe heater to the bottom of the secondary heat exchanger. It will span the front, left-hand side of the primary heat exchanger as shown in Figure 24, page 35. See also item 413, page 70.

- 13.2 Install pipe heaters just below connection points "A" and "B." (See page 70.) Secure each one with a clip (item 451).
- 13.3 Install a pipe heater just above connection point "C." (See page 70.) Secure it with item 451.
- 13.4 Install a pipe heater to the left of connection point "D." (See page 70.) Secure it with item 451.

14. Install the fuse box at the location shown in Figure 42, page 45. (See also items 703 & 120, p. 68.) Secure it by hand-tightening both mounting screws.

15. Hook up the freeze protection heater wiring:

- 15.1 At the top of the fuse box location, connect two plugs and receptacles as described in Figure 39.

NOTE: All connectors with yellow wires are connected to the same circuit, so the order in which you connect them does not matter.

- 15.2 Below the fuse box location, connect three plugs and receptacles as shown in Figure 40.

Secure these wires with the cable clamp on the left side of the cabinet.

16. Install the computer board (PCB):

- Small feet at the bottom must fit into the corresponding holes in the case.
- Insert the screw at the top of the computer board, then hand-tighten it to secure the board

Figure 39.

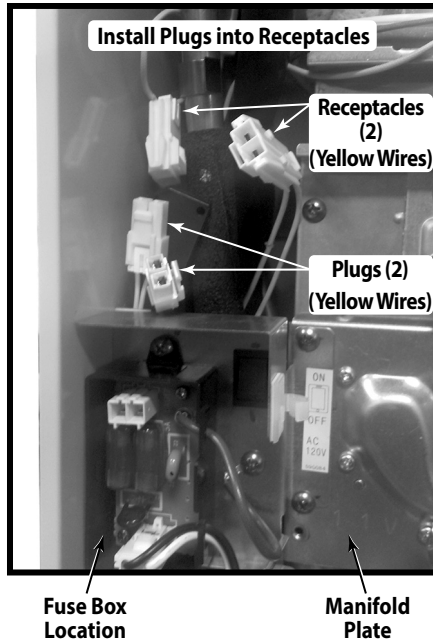

to the fuse box assembly. See Figure 42.

- 16.1 Connect all of the wires to the computer board. All of the wire connectors are uniquely sized and shaped to fit only in the correct connector on the board. **If necessary, refer to the schematic on page 22.**

NOTE:

- There are two (2) receptacles on the computer board that will be open. See Figure 41, page 44.
- Item "1" in the schematic (p. 22) uses a separate wiring assembly which includes three wires: yellow, green, and orange.) Install it as shown in the schematic.
- Install the connector with four white wires

Figure 40.

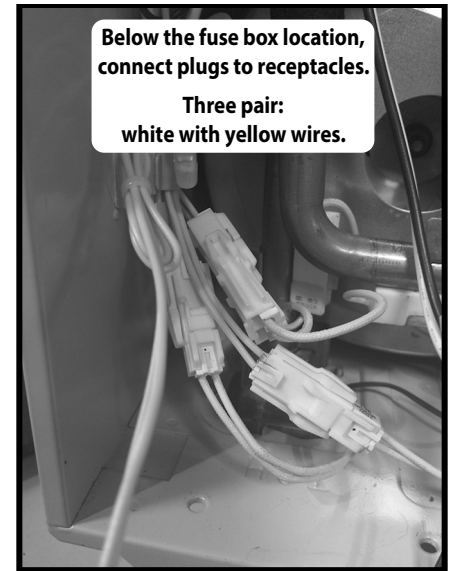

into the computer board. (See checkpoints K1/K2 in the schematic on page 22.)

Figure 41. Open Receptacles (2)

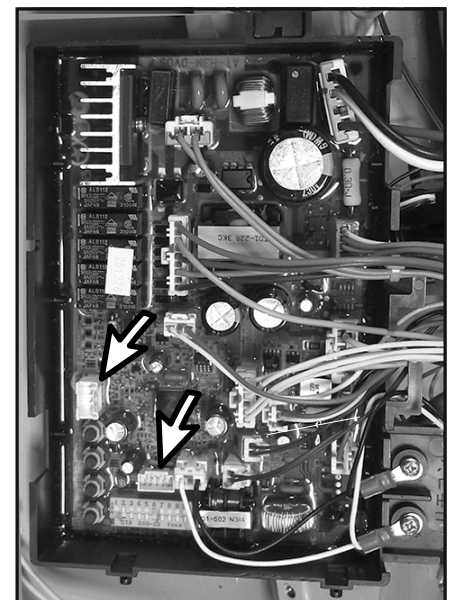

- 16.2 Insert the connector from the power supply cable to the top port on the fuse box. See Figure 43.
- 16.3 Use screws to secure three (3) green wires to the bottom, center of the manifold plate. See “Ground Connections” in Figure 24, page 35. (There are two mounting holes for these wires.) The three green wires can be identified as follows:
- One green wire comes from the power cord.
 - Two green wires come from connectors on the computer board.

17. Complete the wiring connections inside the cabinet:

- Locate the plug and receptacle with **blue** wires. Plug them together at the right-hand side of the cabinet.
 - Locate the plug and receptacle with **yellow** wires. Plug them together at the top, right-hand corner of the cabinet.
 - Plug in the flame rod wire connectors (2). See “Flame Rod & AFR Wire Connections” in Figure 24, page 35.
 - Plug in the high limit switch and exhaust thermistor connectors. See Figure 24, page 35 (top).
- 18. Plug the wires from the temperature controller (item 721, p. 67) to the matching wires from the computer board. (These wires are black and white).**

Figure 42.

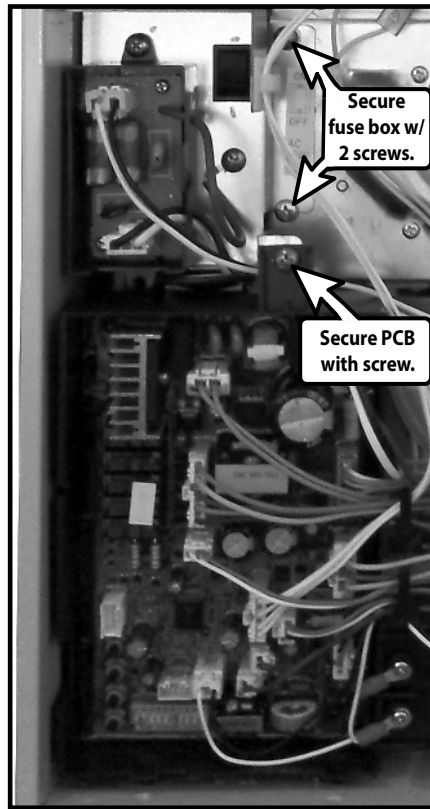

19. Verify that all water connections are tight and that there are no parts left over.

20. Restore power to the water heater.

21. Open the gas valve slowly and check for leaks. If any gas leaks appear, shut off the gas and disconnect power to the water heater.

22. Turn on water to the heater and test for proper operation.

23. Verify that there are no water or gas leaks.

Figure 43



24. Insert the temperature controller into the opening of the front cover, then reinstall the front cover.

If you have any questions, please contact technical support.

Replacing the Heat Exchanger (Outdoor Models)

Tools:

#2 Phillips Screw Driver
(a magnetic tip is helpful)

⚠ WARNING!

- Disconnect power by opening the circuit breaker or removing the fuses before installing or servicing.**
- Use a non-contact circuit tester to confirm that power is off before working on or near any electrical parts.**
- Ensure that the gas supply is shut off at the manual gas shutoff valve.**
- Replace the front cover after servicing.**

Consider removing the following sections from this manual for easy reference:

- **“Component Diagrams/Item Numbers” (starting on page 67).**
- **Figure 25, page 36, which shows the location of basic components.**

This will allow you to lay the loose pages beside this manual for easier reference.

Also, screw sizes vary. We recommend bagging and labeling screws as you remove them, or reinstall them in their proper places as you proceed with disassembly. This will make reassembly easier.

Removing Heat Exchanger Components (Outdoor Models)

1. Shut the unit down as follows:

- 1.1 Shut Off power and gas supply as follows:
 - 1.1.1 Shut off Power by disconnecting the power cord or shutting off the power disconnect.
 - 1.1.2 Shut off the gas supply to the water heater at the manual gas shutoff valve.
- 1.2 Drain the water from the heater as follows:
 - 1.2.1 Close the shutoff valves on the hot and cold side of the heater.
 - 1.2.2 IF isolation valves are installed: open up the drain ports.
 - 1.2.3 IF isolation valves are not installed: remove the filter (item 405, page 70) and open the pressure relief valve.

2. Remove the computer board as follows (item 701, page 68; see also Figure 25 on page 36):

CAUTION:

- During the next steps, consider taking a digital photo to aid in reassembly.
- Do not touch the circuit board components. Doing so may cause damage by electrostatic discharge.

- 2.1 Disconnect all wire connectors from the computer board.
- 2.2 Remove the screw at the top of the computer board assembly, then remove the board (Figure, p. 36).

3. Remove the fuse box assembly (items 703, 120; page 46):

- 3.1 Disconnect the connector at the top port which comes from the main power supply.
- 3.2 Disconnect the freeze protection heater wires. There are 5 sets of white connectors with yellow wires (two above the assembly and three below the assembly).
- 3.3 Remove the screw that secures the fuse box and lift the fuse box away.

4. Remove the flow sensor/control valve (item 402, page 70; see also Figure 25, page 36):

- 4.1 Remove fasteners 16A and 14-22 (items 458 and 459, page 70).
- 4.2 Pull the cold connection tube (item 462, p. 70) from the outlet of the flow sensor/control valve and lift the valve off of the inlet connection. You may have to twist the valve off of the inlet connection.

5. Remove the cold connection tube (item 462, page 70) as follows:

- 5.1 Disconnect fastener 14-22 (item 458, page 70).

Flame Rod Wire Connector:
To remove, pinch flat sides at end with your finger nails, then slide connector off the spade.

Figure 44.

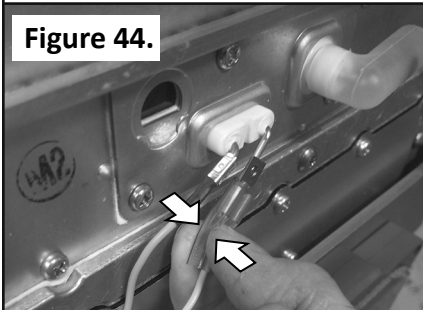

- 5.2 Remove two heaters and clips (located at top and bottom of tube):
- Items 413 & 451, p. 70.
 - Items 414 & 451, p. 70.

See also Figure 47.

- 5.3 Slide the cold connection tube downward and remove it.

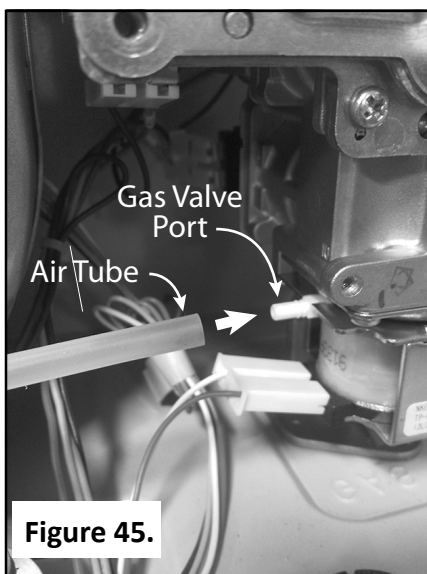

Figure 45.

6. Remove the igniter assembly:

- 6.1 Remove the screw that secures the igniter assembly (Figure 25, page 36).
- 6.2 Disconnect the igniter wire at the igniter rod wire connection (Figure 25, page 36).

7. Disconnect the blue wires from the high limit switch. See "High Limit Switch (Heat Exchanger)," Figure 25, page 36.

The wires are locked onto the connectors. Pinch the flat sides of each connector to release it.

8. Remove the Gas Valve and Manifold Plate Assembly:

- 8.1 Unplug wire connectors from the air/fuel ratio rod (AFR), flame rod, and igniter. See Figure 44.
- 8.2 Remove the screws that secure the green ground wires to the manifold plate.

Manifold Screws:

- **DO NOT** remove the screws shown below (indicated by white, crossed-out circles).
- **Remove the remaining screws along the outside edge (except as indicated).**

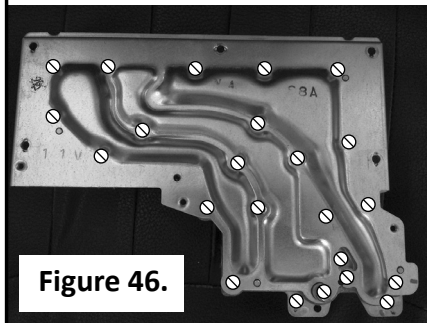

Figure 46.

Example:
Freeze Protection Heaters with Clips

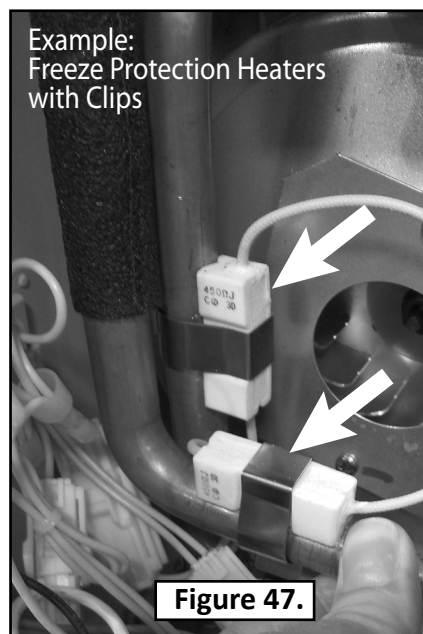

Figure 47.

- 8.3 Remove the screws that secure the manifold plate (Figure 46).

IMPORTANT: Remove only the screws along the outside edges of the manifold plate.

- **DO NOT** remove the screws securing the manifold plate to the gas valve.
- **DO NOT** remove the screws along the interior of the manifold plate.

- 8.4 Remove the screw on the left side of the gas valve that secures the power cord.
- 8.5 Disconnect the air tube off the left side of the gas valve (Figure 45).
- 8.6 Disconnect the connector on the right side (blue wires) which goes to the overheat cutoff fuse (Figure 25, page 36).

8.7 Remove the brass screw securing the gas valve to the gas connection. The screw is located at the bottom, right-hand side of the gas valve. See Figure 24, page 35.

8.8 Lift the manifold plate/gas valve assembly upward to remove it from the gas inlet connection. (The gas valve and manifold are still connected together.)

You may need to twist the gas valve/manifold assembly slightly.

8.9 Unplug the wire connectors at the solenoid valve (SV3); the solenoid valve is attached to the corner of the manifold plate. See Figure 49.

8.10 Disconnect the solenoid connectors (Item 707, p. 69) from the gas valve. (There are three connectors.)

8.11 Disconnect the proportional gas valve connector (item 711, p. 69) from the assembly.

8.12 Inspect the gaskets on the manifold plate for any tears. If compromised, replace with part number 319143-044 (item 113) and/or 319143-045 (item 114). See page 69.

8.13 Inspect the o-ring (item 151, p. 69) and gas inlet ring (item 119, p. 69) on the gas connection for cuts or breaks.

If damaged, replace with part number 319143-057

(item 151) and/or 319143-049 (item 119). See page 69.

9. Remove the burner from the combustion chamber:

9.1 Remove two screws below the burner, at the back. (See Figure 48.)

9.2 Remove three screws across the front of the burner. (Figure 48.) Do not remove the screws around the flame sensor/AFR and igniter rods.

9.3 Slide the burner out toward you. You may need to use a small set of pliers to loosen the burner on the sides and then pull from the middle portion of the inlet holes.

9.4 Check the gaskets on the burner for any tears. If there are, replace the gasket with part number 319143-032.

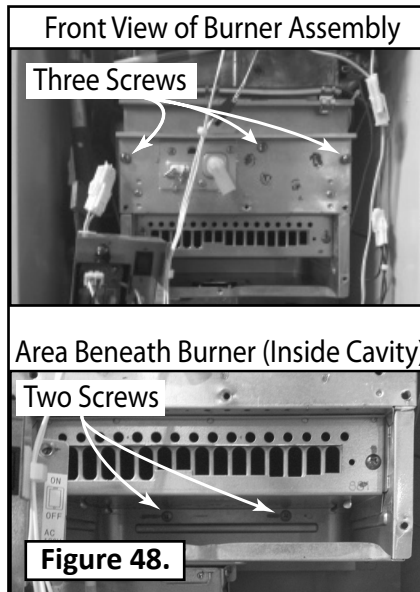

10. Disconnect and remove the following items:

10.1 Disconnect the condensate drain line (item 415, page 70) from the secondary heat exchanger assembly by pulling down. Do not remove the drain line from the outlet connection at the bottom of the cabinet.

10.2 Remove fastener 16-25 (item 460, page 70) from the outlet tubing and outlet water connection.

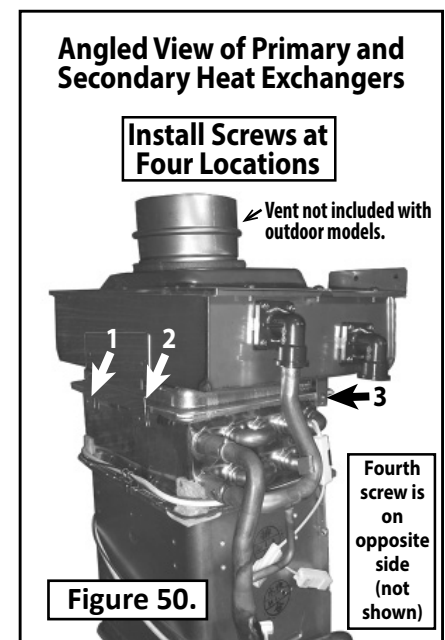
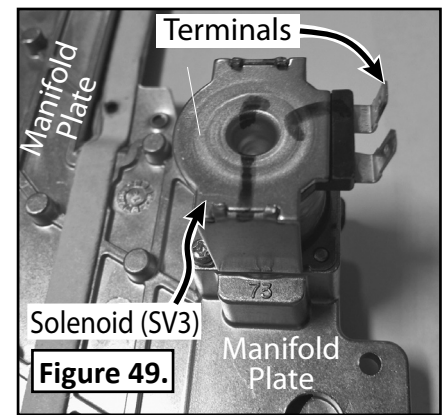

Three Screws Securing the Secondary Heat Exchanger

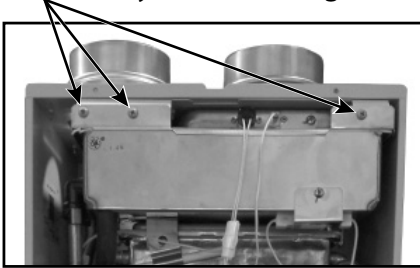

Figure 51.

- 10.3 Slide the outlet tube up and out of the outlet water connection. Remove the tube.
- 10.4 Remove the three screws at the top of the secondary heat exchanger that are securing it to the case. Refer to Figure 51.

11. Separate the heat exchangers:

- 11.1 Lift the heat exchangers out of the cabinet.
- 11.2 Separate the primary and secondary heat exchangers.
 - 11.2.1 Remove fastener 14-22 (item 458, p. 70) from the tube on the left-hand side. (This tube connects the primary heat exchanger to the secondary heat exchanger.)
 - 11.2.2 Remove the four screws that connect the primary and secondary heat exchangers (Figure 50).
- 11.3 IF you are replacing the primary heat exchanger assembly, go to “Preparing the New Primary Heat Exchanger for Installation (Outdoor Models).”

IF you are replacing the

secondary heat exchanger assembly, go to “Preparing the New Secondary Heat Exchanger for Installation (Outdoor Models).”

Preparing the New PRIMARY Heat Exchanger for Installation (Outdoor Models)

The primary heat exchanger is the same assembly for both indoor and outdoor models. It comes with:

- A combustion chamber attached to the bottom of the heat exchanger. See “Combustion Chamber,” page 70.
- A plate attached at the top with a gasket surrounding the flue gas connection to the secondary heat exchanger. See “Heat Exchanger (Primary)” on page 70.

1. Make sure the gasket on top of the primary heat exchanger is not compromised. If it is, contact technical support.

2. Remove the following items from the primary heat exchanger and INSTALL THEM IN THE SAME LOCATIONS ON THE NEW HEAT EXCHANGER:

- High limit switch on the right side (item 411, p. 70). See also Figure 25 on page 36.
- Over-heat Cutoff Fuse (OHCF) (item 412, p. 70) and its five clips. (Four clips are attached to the primary heat exchanger and one is attached to the outlet tube.) See also Figure 25 on page 36.

- Air tube and its connector/nipple on the bottom of the combustion chamber (Figure 52).
- Two (2) freeze protection heaters and clips; one is located on the outlet tube near the bottom and the other is located on the connection tube from the secondary heat exchanger. (See items 413 and 414 on page 70. See also Figure 47, page 47.)
- O-Rings on the connection tubes: Item 455 (p. 70) is attached to the connection tube from the secondary heat exchanger. Item 457 (p. 70) is attached where the outlet water tube connects to the outlet water connection. (See connection points “A” and “C,” p. 70).

CAUTION: These o-rings are different sizes, so label them and keep them separated.

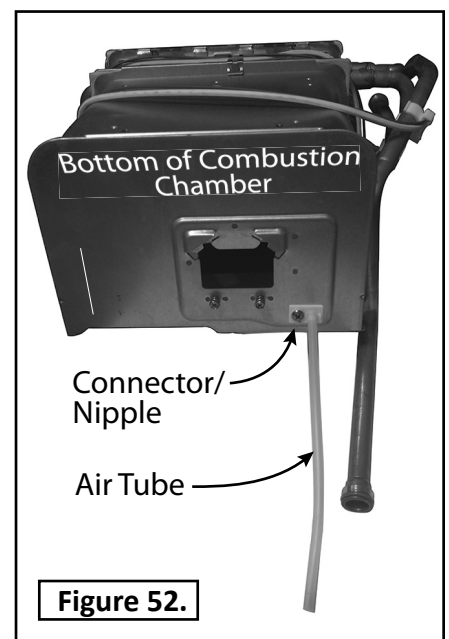

Figure 52.

3. Disconnect and remove the fan from the combustion chamber as follows:

- 3.1 Remove the 2 Phillips/hex head screws pointing down from the fan using a #2 Phillips head screw driver.
- 3.2 Slide the fan toward you to remove it from the slots that hold it in place.
- 3.3 Complete the steps in "Preparing the New Secondary Heat Exchanger for Installation (Outdoor Models)."

Preparing the New SECONDARY Heat Exchanger for Installation (Outdoor Models)

NOTICE: Assembly of the secondary heat exchanger is different for the indoor and outdoor models.

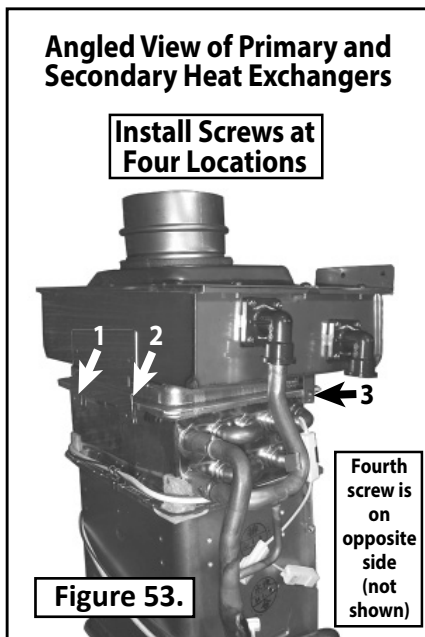

1. Remove the following items from the secondary heat exchanger, then INSTALL THEM IN THE SAME LOCATIONS ON THE NEW HEAT EXCHANGER:

- Flue gasket (item 152, p. 70) which is located around the exhaust.
- Flue exhaust port (item 153, p. 70), which is secured by four screws.

2. Complete the steps in "Installing the Heat Exchanger (Outdoor Models)."

Installing the Heat Exchanger (Outdoor Models)

1. Connect the primary and secondary heat exchangers, making sure that the flange on top of the primary heat exchanger (male connector) goes into the connection on the bottom of the secondary heat exchanger. The tube

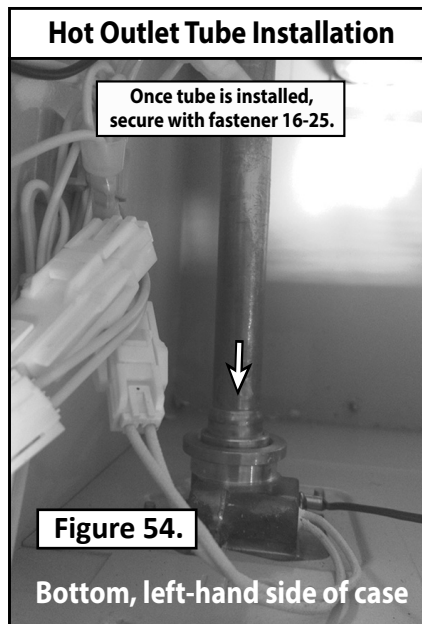

Angled View of Primary and Secondary Heat Exchangers

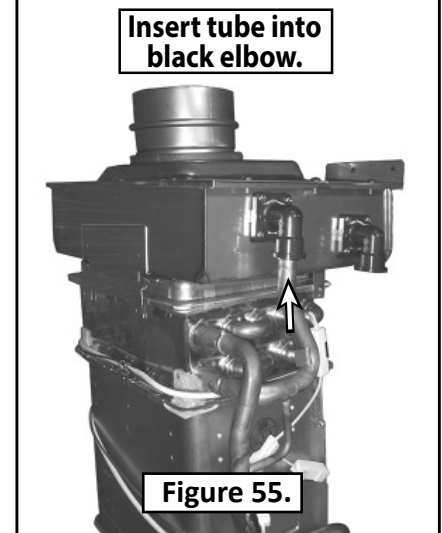

from the primary heater will insert into the back elbow on the secondary heat exchanger. (Figure 55.)

2. Make sure that the screw holes on the sides and back line up properly. Insert and hand-tighten all four (4) mounting screws. See Figure 53.
3. Attach fastener 14-22 (item 458, page 70) where the connection tube from the primary heat exchanger and the back elbow on the secondary heat exchanger meet. (Figure 60, page 52.)

("14-22" is marked on the end of this clip; all such clips are marked on the end in the same manner.)
4. Install the fan with the air inlet facing toward the front.
 - 4.1 Slide the fan discharge into the slots on the bottom of the combustion chamber.

4.2 Line up the holes, then insert and hand-tighten two (2) hex head screws (item 54). See page 69.

5. Secure the heat exchangers to the case:

Insert and hand tighten three (3) mounting screws as shown in Figure 25, page 36. This will secure the heat exchanger assembly to the heater case.

6. Install the burner into the combustion chamber. (See page 70.) There are grooves on the sides of the combustion chamber; the bottom of the burner will slide along the grooves.

6.1 Insert and hand tighten two (2) screws below the burner, at the back. (See Figure 48, page 48.) These screws will secure to the back of the cabinet. You may need to push the assembly up some in order to line up the holes.

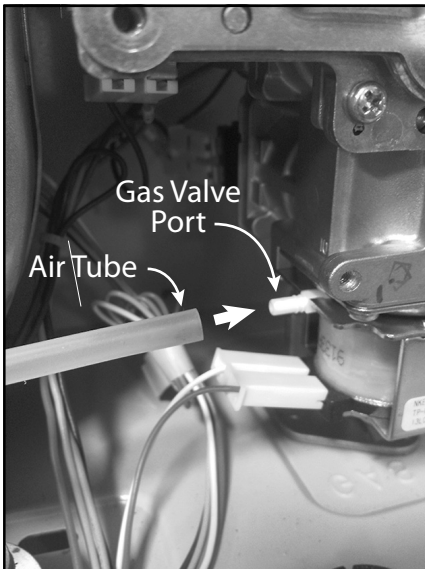

Figure 56.

6.2 Insert and hand tighten three (3) screws along the top, front portion of the burner. See Figure 48, page 48.

7. Insert the outlet tubing into the water outlet connection, making sure that the brass ring on the tube goes all the way in and is flush with the top of the outlet connection. (Figure 54.) Install fastener 16-25 (stamped on the end of the fastener). See also item 460 on page 70.

8. Attach the top of the condensate drain tube to the port on the bottom of the secondary heat exchanger. See Item 415 and connection point "E" on p. 70.

9. Install the manifold plate/gas valve assembly (item 102, p. 69) to the combustion chamber:

9.1 Make sure the screen on the inlet to the gas valve is still in place.

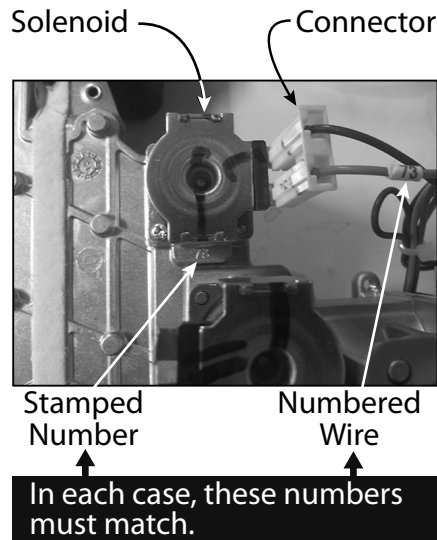

Figure 57. Gas Valve Wiring

9.2 Attach the wire connectors to each of the solenoid valves.

- Each connector has a dark blue wire, except for the proportional valve. The other wire colors will vary.
- Each set of wires has a tag with a number on it. Each solenoid valve has a number stamped next to it. During installation, each wire number must match its solenoid valve number. See Figure 57.
- Install each connector to the solenoid valve with the matching number.
- The proportional valve does not have a number and is located at the bottom of the assembly. Wire colors: red & white.

9.3 Slide the gas valve/manifold plate assembly onto the gas inlet connection. You may need to rotate the gas valve while sliding down for an easier fit. The tab on the gas valve connection should line up behind the tab on the gas inlet connection.

9.4 Secure the gas valve to the gas inlet by installing the brass screw (with washer) through both tabs at the connection. **Hand-tighten only.** See Figure 25, page 36.

9.5 Attach the air tube from the bottom of the combustion chamber to the port on the left side of the gas valve. (See Figure 56 and Figure 52, page 49.)

- 9.6 Secure the power cord to the gas valve as shown in Figure 25, page 36. (See the “Power Cord Mounting Tab” callout.) **Hand-tighten only.**
- Use the mounting tab and the M4X10 screw.
 - The mounting hole is located on the left side of the gas valve.

- 9.7 Line up the manifold plate with the holes on the burner and combustion box. Insert and hand tighten the top center screw on the manifold plate. (See “Manifold Plate,” page 36.)

- 9.8 Hand tighten the remaining manifold plate screws. Do not overtighten.

NOTE: Leave the fuse box mounting holes open (left side of plate). The fuse box will be mounted later.

10. Install the igniter assembly to the lower, right-hand corner of the manifold plate. (See “Igniter Assembly” and “Igniter Rod Wire Connection” on page 36; see also item 709 on page 69 .)

Figure 58.

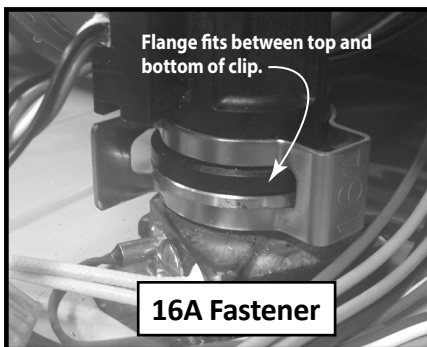

Figure 59.

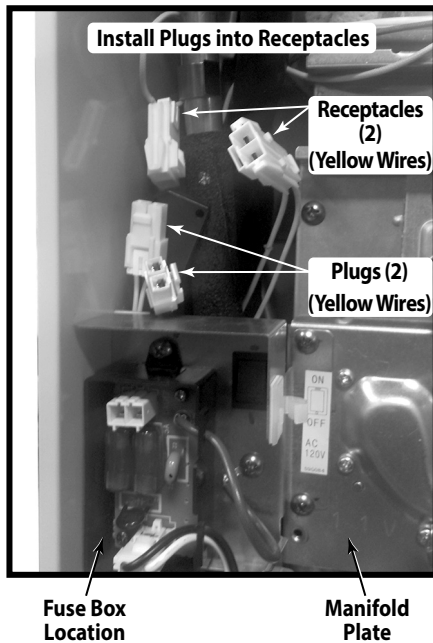
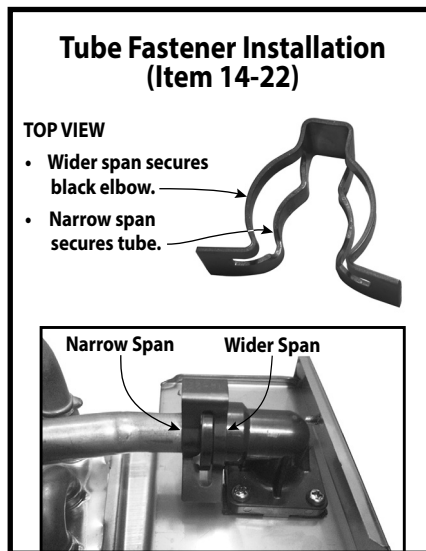

Figure 60.



- 10.1 Insert and hand tighten the screw.
- 10.2 Slide the black igniter wire onto the igniter rod. (Figure 25, page 36).

Figure 61.

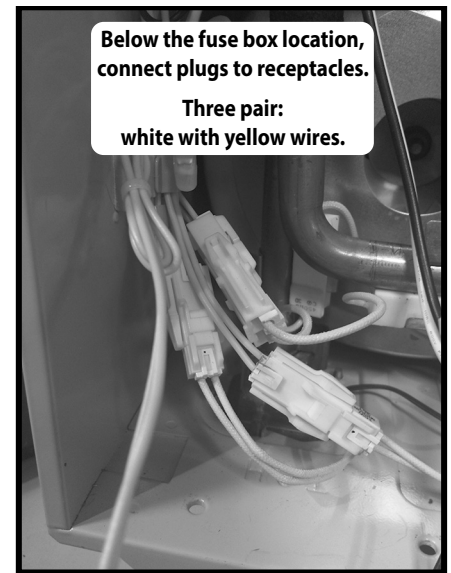
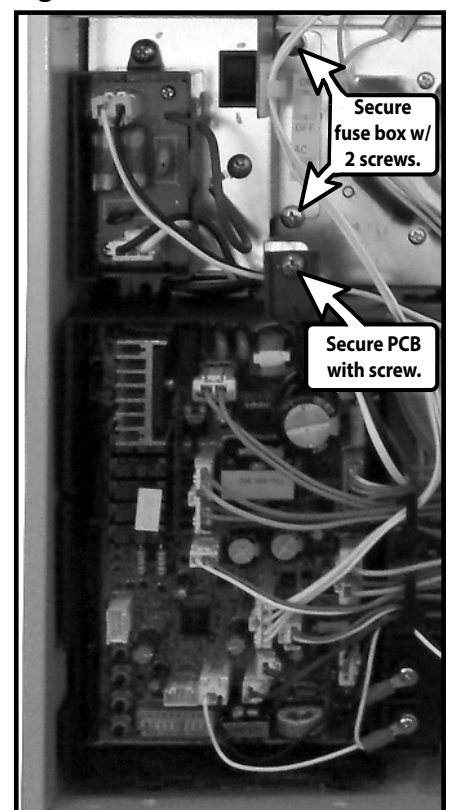

Figure 62.



11. Install the flow sensor/control valve (item 402, p. 70) and cold connection tube (item 462, p. 70) as follows:

- 11.1 Insert the long, straight end of the cold connection tube into the elbow on the secondary heat exchanger. See connection point "B" on page 70 (shown in two places).
- 11.2 Install the flow sensor/control valve onto the inlet water connection (Figure 25, page 36).
- 11.3 Insert the end of the cold connection tube into the outlet of the flow sensor/control valve. See connection point "D" on page 70 (shown in two places).
- 11.4 Install the fasteners:
 - One 16A fastener. See item 459 on p. 70, which secures the inlet of the flow sensor/control valve to the inlet water connection. "16A" is marked on the end of this clip.

Install the clip as shown in Figure 58.
 - Two 14-22 fasteners. ("14-22" is marked on the end of each clip.)

See both instances of item 458 on page 70. These fasteners secure the cold connection tube at each end. Install as described in Figure 60.

See also connection points "B" and "D" on page 70. The cold connection tube's brass rings must be

fully inserted at each connection point.

- 11.5 Verify that all of the fasteners on the water tubing are installed properly
- 11.6 Install the cold water inlet filter. (Refer to the water heater's manual, if needed.)
- 11.7 Test for leaks by turning on the water supply to the water heater. Check the water tube connections for any drips or leaks. If any appear, turn off the water, drain the water heater, dry the components that got wet, and fix the leak.

12. Verify that the following pipe heaters are installed. See the following pipe heaters on page 70: item 413 (three instances) and item 414 (two instances).

If installation is still needed,

- 12.1 Install the long pipe heater to the bottom of the secondary heat exchanger. (It will span the front, left-hand side of the primary heat exchanger as shown in Figure 25, page 36. See also item 413, page 70.
- 12.2 Install pipe heaters just below connection points "A" and "B." (See page 70.) Secure each one with a clip (item 451).
- 12.3 Install a pipe heater just above connection point "C." (See page 70.) Secure it with item 451.
- 12.4 Install a pipe heater to the left of connection point "D." (See page 70.) Secure it with item 451.

13. Install the fuse box assembly on the left side of the manifold plate. (See items 703 & 120, page 68;

see also Figure 62.) Hand tighten two screws to secure it to the manifold plate.

14. Hook up the freeze protection heater wiring:

14.4.1 At the top of the fuse box location, connect two plugs and receptacles as described in Figure 59.

NOTE: All connectors with yellow wires are connected to the same circuit, so the order in which you connect them does not matter.

14.4.2 Below the fuse box location, connect three plugs and receptacles as shown in Figure 61.

Secure these wires with the cable clamp on the left side of the cabinet.

15. Install the computer board (PCB):

- Small feet at the bottom must fit into the corresponding holes in the case.
- Insert the screw at the top of the computer board, then hand-tighten it to secure the board to the fuse box assembly. See Figure 62.

15.1 Connect all of the wires to the computer board. All of the wire connectors are uniquely sized and shaped to fit only in the correct connector on the board. **If necessary, refer to the schematic on page 22.**

NOTE:

- There are three (3) receptacles on the computer board that will be open. See Figure 63.

- Item “I” in the schematic (p. 22) uses a separate wiring assembly which includes three wires: yellow, green, and orange.) Install it as shown in the schematic.

15.2 Insert the connector from the power supply cable to the top port on the fuse box. See Figure 64.

16. Complete the wiring connections inside the cabinet:

- Locate the plug and receptacle with **blue** wires. (They are at the mid-center of the cabinet, on the right-hand side.) Plug them together.
- Use screws to secure three (3) green wires to the bottom, center of the manifold plate. See “Ground Connections” in Figure 25, page 36. (There are two mounting holes for these wires.) The three green wires can be identified as follows:
 - One green wire comes from the power cord.
 - Two green wires come from connectors on the computer board.
- Plug in the flame rod wire connectors (2). See “Flame Rod & AFR Wire Connections” in Figure 25, page 36.

17. Verify that all water connections are tight and that there are no parts left over.

18. Restore power to the water heater.

19. Open the gas valve slowly and check for leaks. If any gas leaks appear, shut off the gas and disconnect power to the water heater.

20. Turn on water to the heater and test for proper operation.

21. Verify that there are no water or gas leaks.

If you have any questions, please contact technical support.

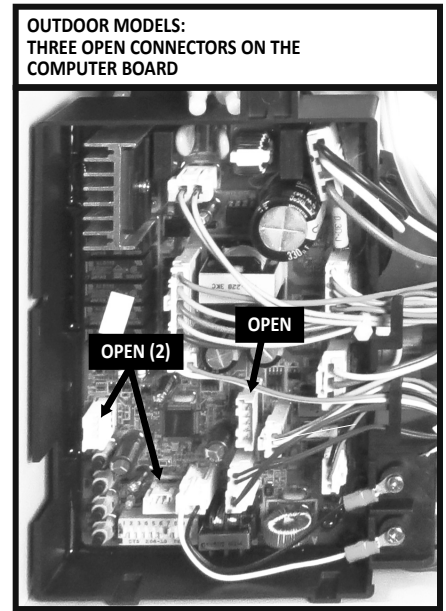

Figure 63.



Figure 64.

Flow Sensor/ Control Valve Removal and Installation

Tools:

#2 Phillips Screw Driver

See also Checking the Flow Sensor, page 27.

Removal

1. **Shut off power by disconnecting the power cord or shutting off the power disconnect.**
2. **Shut off the gas supply to the water heater.**
3. **Drain the water from the water heater.**
 - 3.1 Close the shutoff valves on the hot and cold side of the heater.
 - 3.2 If isolation valves are installed, open the drain ports.
 - 3.3 If isolation valves are not installed, remove the filter (item 405, p. 70) and open the pressure relief valve.
4. **FOR INDOOR MODEL ONLY: Remove the Temperature Controller (item 721, p. 67) by disconnecting it at the white connectors that go to the computer board.**

5. **Remove the computer board (PCB). See Item 701, p. 68; see also Figure 41.**
 - 5.1 Disconnect all wires from the PCB.
 - 5.2 Remove the screw at the top and remove the board.
6. **Remove the flow sensor/control valve (item 402, p. 70) as follows:**
 - 6.1 Remove fasteners 16A and 14-22 (items 458, 459)
 - 6.2 Pull the cold connection tube (item 462, p. 70) from the outlet of the flow sensor/control valve, then lift the valve off the inlet connection. You may have to twist the valve off inlet connection.
7. **Inspect the o-rings on the inlet water connection and the cold connection tube for cuts or wear. Replace as needed.**
 - O-ring on inlet water connection: part no. 319143-083.
 - O-ring on cold connection tube: part no. 319143-100.

Installation

1. **Install the flow sensor/control valve (item 402, p. 70) onto the inlet water connection.**
2. **Connect the cold water connection tube (item 462, page 70) to the outlet of the flow sensor/control valve.**
3. **Install the fasteners:**
 - One 16A fastener. See item

459 on p. 70, which secures the inlet of the flow sensor/control valve to the inlet water connection. "16A" is marked on the end of this clip.

- Two 14-22 fasteners. ("14-22" is marked on the end of each clip.)

See both instances of item 458 on page 70. These fasteners secure the cold connection tube at each end. Install as described in Figure 60, page 52.

See also connection points "B" and "D" on page 70. The cold connection tube's brass rings must be fully inserted at each connection point.

4. **Turn on the water and verify that there are no leaks at the connections. If there are leaks, shut off the water, drain the water heater, and fix the leak.**

5. Install the computer board (PCB):

- Small feet at the bottom must fit into the corresponding holes in the case.
- Insert the screw at the top of the computer board, then hand-tighten it to secure the board to the fuse box assembly. (Figure 62, page 52.)

5.1 Connect all of the wires to the computer board. All of the wire connectors are uniquely sized and shaped to fit only in the correct connector on the board. Refer to the schematic on page 22.

- Indoor Models:
There are two (2) receptacles on the computer board that will be open (Figure 65).

- Outdoor Models: There are three (3) receptacles on the computer board that will be open (Figure 65).
- Item “I” in the schematic (p. 22) uses a separate wiring assembly which includes three wires: yellow, green, and orange.) Install it as shown in the schematic.

5.2 Use screws to secure three (3) green wires to the bottom, center of the manifold plate. See “Ground Connections” in Figure 25, page 36. (There are two mounting holes for these wires.) The three green wires can be identified as follows:

- One green wire comes from the power cord.
- Two green wires come from connectors on the computer board.

5.3 If necessary, complete the wiring connections inside the cabinet:

- Locate the plug and receptacle with **blue** wires. (They are at the mid-center of the cabinet, on the right-hand side.) Plug them together.
- FOR INDOOR MODEL ONLY: Locate the plug and receptacle with **yellow** wires. Plug them together.

5.4 FOR INDOOR MODEL ONLY: Plug the wires from the temperature controller (item 721, p. 67) to the matching

wires from the computer board. (These wires are black and white).

6. Restore power to the water heater.
7. Open the gas valve slowly, checking for leaks. If gas leaks appear, shut off the gas supply and disconnect power to the water heater.
8. Turn on water to the heater and test for proper operation.
9. Verify that there are no water or gas leaks. Correct any leaks that are found.
10. Reinstall the front cover. (If yours is an indoor model, install the front cover *after* inserting the temperature controller into its opening first.)

If you have any questions, please contact technical support.

Burner Removal and Installation

Tools:

- #2 Phillips Screw Driver

Removal

1. Shut off Power by disconnecting the power cord or shutting off the power disconnect.
2. Shut off the gas supply to the heater.

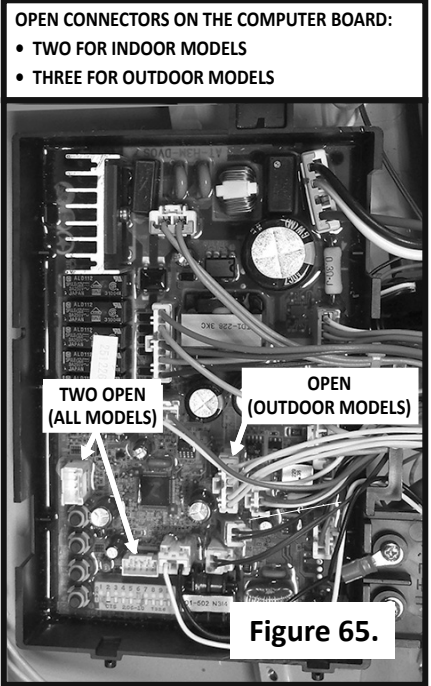

Figure 65.

3. FOR INDOOR MODELS ONLY: Remove the Temperature Controller (item 721, p. 67) by disconnecting it at the white connector.
4. Remove the computer board (PCB). See item 701, p. 68). See also Figure 24, page 35.
 - 4.1 Disconnect all of the wires from the PCB.
 - 4.2 Remove the screw at the top, then remove the board. (If necessary, refer to Figure 62, page 52).
5. Remove the fuse box assembly (items 703 & 120; page 68):
 - 5.1 Disconnect the connector at the top port which comes from the main power supply.

- 5.2 Disconnect the freeze protection heater wires. INDOOR MODELS have 6 sets of white connectors with yellow wires (two above the assembly, three below the assembly, and one below the secondary heat exchanger on the right side). OUTDOOR MODELS have 5 sets of white connectors with yellow wires (two above the assembly, and three below the assembly).
- 5.3 Remove the screw that secures the fuse box and lift the fuse box away. (The last one is not installed on outside models.)

6. Remove the igniter assembly (item 709, p. 69) from the right-hand side. See Figure 24, page 35.
7. Slide the black igniter tube off of the igniter rod. (See "Igniter Rod Wire Connection" in Figure 24, page 35.)

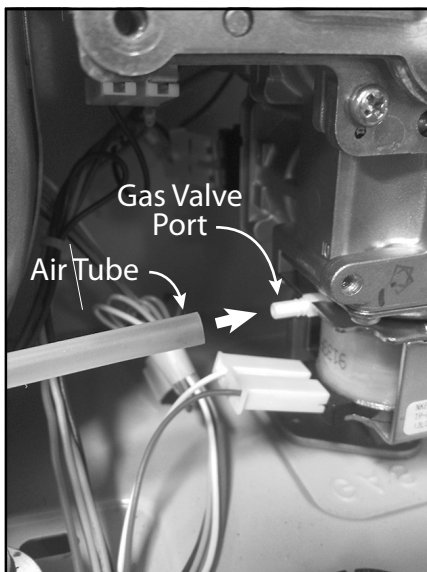

Figure 66.

8. Remove the Gas Valve and Manifold Plate Assembly:

- 8.1 Unplug wire connectors from the air/fuel ratio rod (AFR), flame rod, and igniter. See Figure 68.
- 8.2 Remove the screws that secure the green ground wires to the manifold plate.
- 8.3 Remove the screws that secure the manifold plate (Figure 70).

IMPORTANT: Remove only the screws along the outside edges of the manifold plate.

- DO NOT remove the screws securing the manifold plate to the gas valve.
 - DO NOT remove the screws along the interior of the manifold plate.
- 8.4 Remove the screw on the left side of the gas valve that secures the power cord.
- 8.5 Disconnect the clear air tube off the left side of the gas valve. (See Figure 66.)
- 8.6 Disconnect the connector on the right side (blue wires) which goes to the overheat cutoff fuse (Figure 24, page 35).
- 8.7 Remove the screw securing the gas valve to the gas connection. The screw is located at the bottom, right-hand side of the gas valve; see Figure 24, page 35.
- 8.8 Lift the manifold plate/gas valve assembly upward to remove it from the gas

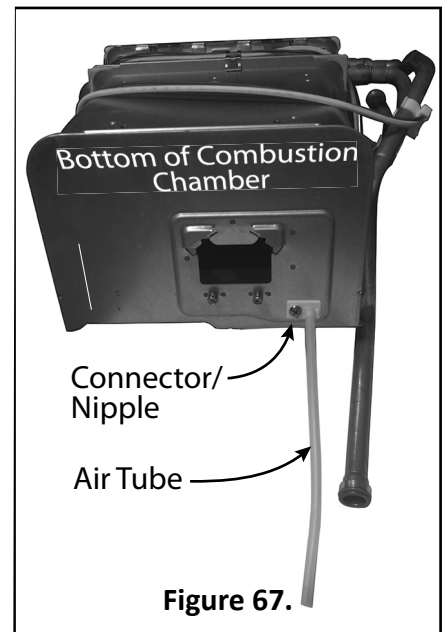

Figure 67.

inlet connection. (The gas valve and manifold are still connected together.)

You may need to twist the gas valve/manifold assembly slightly.

- 8.9 Unplug the wire connectors at the solenoid valve (SV3); the solenoid valve is attached to the corner of the manifold plate. If necessary, refer to Figure 72.

Flame Rod Wire Connector:
To remove, pinch flat sides at end with your finger nails, then slide connector off the spade.

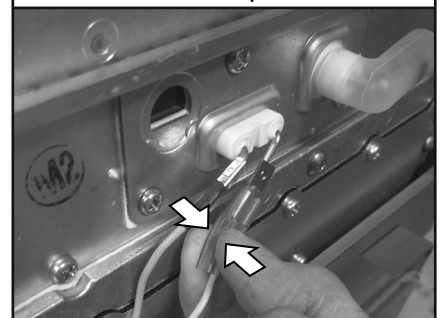
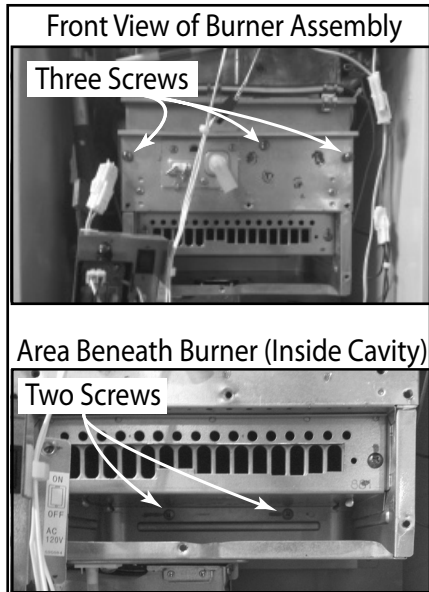

Figure 68.

Figure 69.



- 8.10 Disconnect the solenoid connectors (Item 707, p. 69) from the gas valve. (There are three connectors.)
- 8.11 Inspect the gaskets on the manifold plate for any tears. If compromised, replace with

Manifold Screws:

- **DO NOT** remove the screws shown below (indicated by white, crossed-out circles).
- Remove the remaining screws along the outside edge (except as indicated).

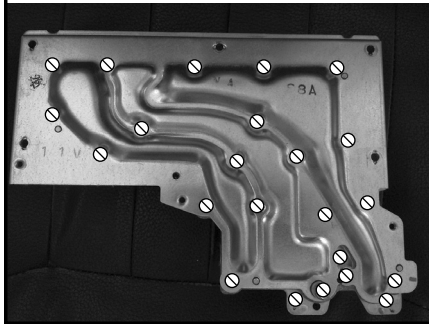

Figure 70.

part number 319143-044 (item 113) and/or 319143-045 (item 114). See page 69.

- 8.12 Inspect the o-ring (item 151, p. 69) and gas inlet ring (item 119, p. 69) on the gas connection for cuts or breaks.

If damaged, replace with part number 319143-057 (item 151) and/or 319143-049 (item 119). See page 69.

9. Remove the burner from the combustion chamber:

- 9.1 Remove three screws across the front of the burner (Figure 69). **DO NOT** remove the screws around the flame sensor/AFR and igniter rods.
- 9.2 Remove two screws below the burner, at the back (Figure 69).
- 9.3 Slide the burner out toward you. If it is difficult to remove, try the following:
 - 1.) Grasp an oval air vent on the front of the burner (at the edge on either side).
 - 2.) Pull firmly while pushing on the bottom of the combustion chamber to provide leverage.
 - 3.) Repeat on the opposite side.
 - 4.) Pull from the center. It should slide out easily.
- 9.4 Check the gaskets on the burner for tears. If the gaskets are compromised, replace with part number 319143-032.

Figure 71.

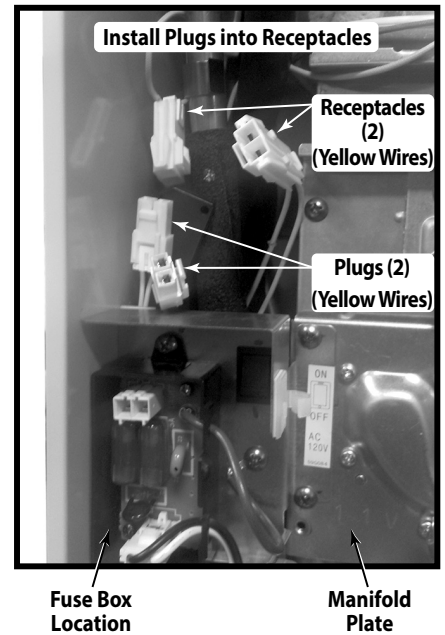
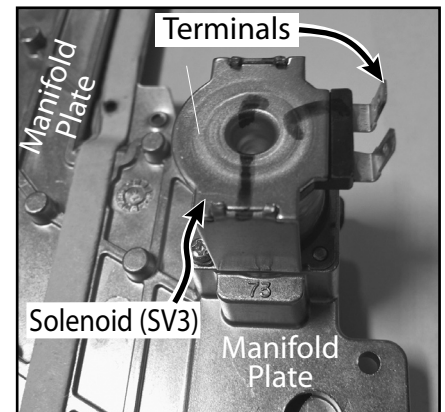

Figure 72.



Installation

1. If a new burner is being installed, then you must complete one of the following steps:

Transfer the burner damper (item 112, p. 69) from the original burner to the new burner. Remove two (2) screws (one on each end), then hand tighten them on the new burner.

-OR-

Install a new burner damper if one is needed (item 112, p. 69). They are different for indoor and outdoor models, although the burner assembly (item 102, p. 69) is the same.

- INDOOR Model: part no. 320273-359. It has **881** stamped on the lower, right-hand corner.
- OUTDOOR Model: part no. 320273-360. It has **882** stamped on the lower, right-hand corner.

2. Install the burner into the combustion chamber. There are grooves on the sides of the combustion chamber to slide the bottom of the burner in between:

- 2.1 Insert and hand tighten two screws below the burner, at the back (Figure 69, p. 58). These screws will secure to the back of the cabinet. You may need to push the assembly up some in order to line up the holes.
- 2.2 Insert three screws along the top portion of the burner, then hand tighten them. See Figure 69, page 58.

3. Install the manifold plate/gas valve assembly (item 102, p. 69) to the combustion chamber:

- 3.1 Attach the white wire connector (blue & red wires) to the solenoid on the back of the manifold plate (Figure 72).
- 3.2 Line up the manifold plate with the holes on the burner and combustion box.
- 3.3 Insert and hand tighten the top center screw on the manifold plate. **Do not overtighten.**
- 3.4 Secure the manifold plate by hand tightening the remaining screws around the outside edge of the plate. **Do not overtighten.**

If necessary, refer back to Figure 70, page 58.
- 3.5 Attach the clear air tube from the bottom of the combustion chamber to the port on the left side of the gas valve. (See Figure 66)

4. Install the igniter assembly (item 709, p. 69) to the lower, right-hand corner of the manifold plate. See Figure 24, page 35.

- 4.1 Insert the screw, then hand tighten it.
- 4.2 Slide the black igniter wire onto the igniter rod. (See "Igniter Rod Wire Connection" in Figure 24, page 35).

5. Hand-tighten a screw at the bottommost hole of the manifold plate (left side). This hole is just below the location at which the

fuse box will be installed. (If needed, refer to Figure 74, page 60).

6. Hook up the freeze protection heater wiring:

- 6.1 At the top of the fuse box location, connect two plugs and receptacles as described in Figure 71, p. 58.

NOTE: All connectors with yellow wires are connected to the same circuit, so the order in which you connect them does not matter.

- 6.2 Below the fuse box location, connect three plugs and receptacles as shown in Figure 73.
- 6.3 Locate the one remaining plug/receptacle pair (yellow wires). Plug them together.

Secure these wires with the cable clamp on the left side of the cabinet.

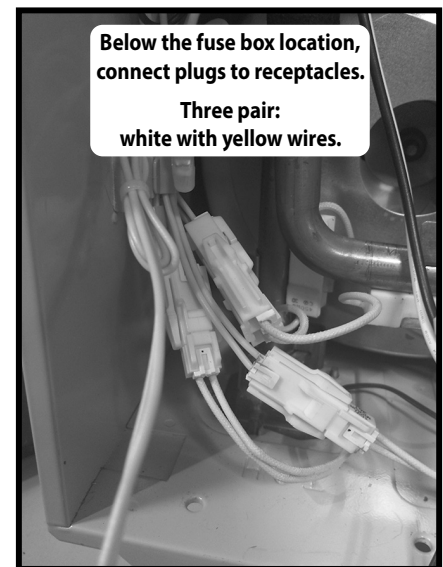

Figure 73.

7. Install the fuse box assembly to the left side of the manifold plate. (See items 709 & 120, page 69.) Hand tighten two screws to secure it to the manifold plate.

8. Install the computer board (PCB):

- 8.1 Small feet at the bottom must fit into the corresponding holes in the case.
- 8.2 Insert and hand tighten the screw at the top of the computer board to secure it to the fuse box.
- 8.3 Connect all of the wires to the computer board. All of the wire connectors are uniquely sized and shaped to fit only in the correct connector on the board. **Refer to the schematic on page 22.**

NOTE:

- Outdoor models have three open connectors on the computer board. Indoor models have two open connectors on the board. See Figure 76.

Prior to fuse box installation, hand-tighten a screw at the bottommost hole (left side).

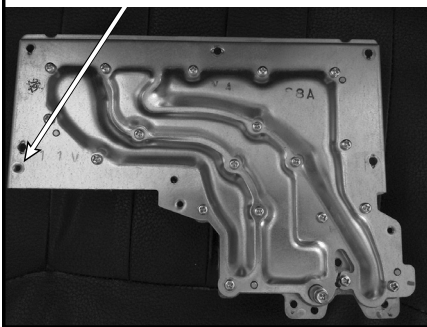

Figure 74.

- Indoor models: One connector will be unused (black and white wires). This connector will be used later to connect the temperature controller to the computer board.

9. Verify that all manifold screws have been reinstalled and hand tightened.

10. Complete the wiring:

- Reinstall all three ground wires. (See "Ground Connections" on page 35.)
- Insert the connector from the power supply cable to the top port on the fuse box. See Figure 75.
- Reinstall the flame rod/AFR wires. (See "Flame Rod & AFR Wire



Figure 75.

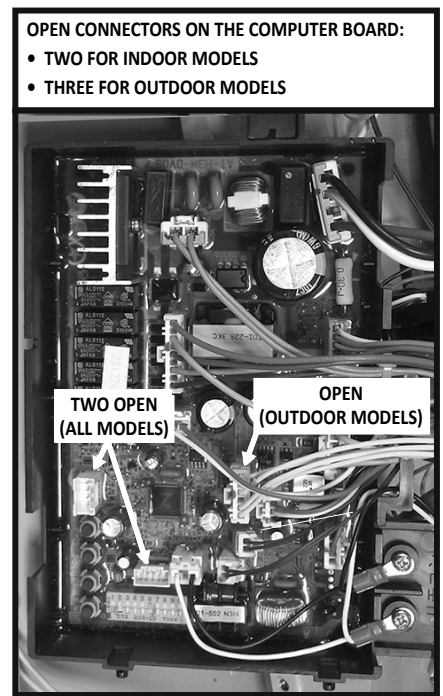

Figure 76.

Connections" on page 35.)

- Locate the unconnected blue wires, then plug them together. (One set of blue wires terminates with a plug; the other terminates with a receptacle.) Wire color: black/white.

11. For Indoor Models: connect the wires from the temperature controller (item 721, page 67) to the wires from the computer board.

12. Verify that all water connections are tight and that there are no parts left over.

13. Restore power to the heater.

14. Slowly open the gas valve and check for leaks. If any gas leaks appear, shut off the gas and turn off power to the heater.
15. Turn on water to the heater and test for proper operation.
16. Verify that there are no water or gas leaks.
17. Outdoor models:
Reinstall the front cover.

Indoor Models:

Insert the temperature controller into the opening of the front cover, then reinstall the front cover.

If there are any questions, please contact technical support.

Manifold Screws:

- DO NOT remove the screws shown below (indicated by white, crossed-out circles).
- Remove the remaining screws along the outside edge (except as indicated).

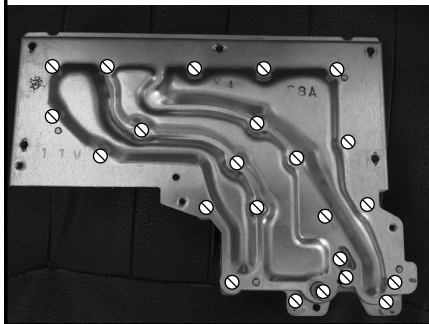

Figure 77.

Gas Valve/ Manifold Plate: Removal and Installation

Tools:

- #2 Phillips Screw Driver
- Gas Manometer

Removal

1. Shut off power by disconnecting the power cord or shutting off the power disconnect.
2. Shut off the gas supply to the water heater.
3. Drain the water from the heater.
 - 3.1 Close the shutoff valves on the hot and cold sides of the water heater.
 - 3.2 If isolation valves are installed, open the drain ports.
 - 3.3 If isolation valves are not installed, remove the filter (item 405, page 70) and open the pressure relief valve.
4. FOR INDOOR MODELS: Remove the Temperature Controller (item 721, page 67) by disconnecting the white connectors that go to the computer board.
5. Remove the computer board as follows. (See Figure 24, page 35.)

- 5.1 Disconnect all of the wires from the computer board.
- 5.2 Remove the screw at the top, then remove the board.

6. Remove the fuse box assembly (items 703 & 120, 703,120, page 68):

- 6.1 Disconnect the connector at the top port which comes from the main power supply.
- 6.2 Disconnect the freeze protection heater wires (yellow) by unlatching each connector.

Inside models have 6 sets of white connectors with yellow wires. (Outside models have 5 sets.) Two sets are located above the assembly, three are located below the assembly, and one is located below the secondary heat exchanger on the right side. (The last one is not installed on outside models.)

7. Remove the igniter assembly from the right-hand side, then slide the black igniter tube off of the igniter rod. (See "Igniter Assembly" and "Igniter Rod Wire Connection" in Figure 24, page 35.)

8. Remove the Gas Valve and Manifold Plate Assembly:

- 8.1 Unplug wire connectors from the air/fuel ratio rod (AFR), igniter, and flame rod.

Remove the screws that secure the manifold plate (Figure 24, page 35).

IMPORTANT: Refer to Figure 77 before you begin.

IMPORTANT: Remove only the screws along the outside edges of the manifold plate.

- DO NOT remove the screws securing the manifold plate to the gas valve.
- **DO NOT remove the screws along the interior of the manifold plate.**

- 8.2 Remove the screw securing the gas valve to the gas connection. The screw is located at the bottom, right-hand side of the gas valve; see Figure 24, page 35.
- 8.3 Lift the manifold plate/gas valve assembly upward to remove it from the gas inlet connection. (The gas valve and manifold plate are still connected together.)

You may need to twist the gas valve/manifold assembly slightly.

Figure 78.

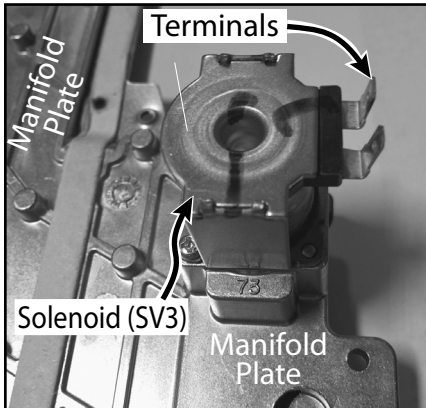

- 8.4 Unplug the wire connectors at the solenoid valve (SV3); the solenoid valve is attached to the corner of the manifold plate. See Figure 78.
- 8.5 Disconnect the air tube off the left side of the gas valve.
- 8.6 Remove the screw on the left side of the gas valve that secures the power cord.
- 8.7 Disconnect the connector on the right side (blue wires) which goes to the overheat cutoff fuse (Figure 24, page 35).
- 8.8 Disconnect the solenoid connectors (Item 707, p. 69) from the gas valve. (There are three connectors.)
- 8.9 Disconnect the blue wires from the high limit switch. See “High Limit Switch (Heat Exchanger)” in Figure 24, page 35.

The wires are locked onto the connectors. **Pinch the sides of each connector to release it.**

- 8.10 Lift the gas valve upward to remove it from the gas inlet connection. You may need to twist the gas valve/manifold assembly slightly.
- 8.11 Remove the wire connectors from all of the solenoid valves on the gas valve.
- 8.12 Inspect the gaskets on the manifold plate for tears. If damaged, replace with part number 319143-044 (item 113) and/or 319143-045 (item 114). See page 69.
- 8.13 Inspect the o-ring (item 151) and gas inlet ring (item 119) on the gas connection for cuts or breaks.

If compromised, replace with part number 319143-057 (item 151) and/or 319143-049 (item 119). See page 69.

Installation

9. Install the gas valve/manifold assembly. (See item 102, p. 69.)

- 9.1 Make sure that the screen on the inlet to the gas valve is still in place.
- 9.2 Attach the wire connectors to each of the solenoid valves.
- Each connector has a dark blue wire, except for the proportional valve. The other wire colors will vary.
 - Each set of wires has a tag with a number on it. Each solenoid valve has a number stamped next to it. During installation, each wire number must match its solenoid valve number. See Figure 79.

Figure 79. Gas Valve Wiring

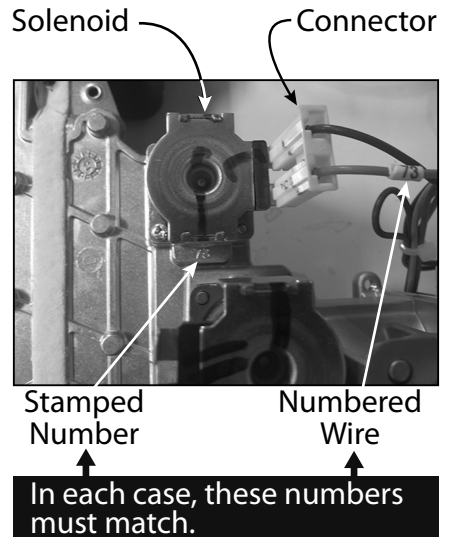

- Install each connector to the solenoid valve with the matching number.
- The proportional valve does not have a number and is located at the bottom of the assembly. It has a red and a white wire.

- 9.3 Slide the gas valve/manifold plate onto the gas inlet connection. You may need to rotate the gas valve while sliding it down for an easier fit. The tab on the gas valve connection should line up behind the tab on the gas inlet connection.
- 9.4 Secure the gas valve to the gas inlet by installing a screw through both tabs at the connection (hand-tight only). See Figure 24 on page 35.

Figure 80.

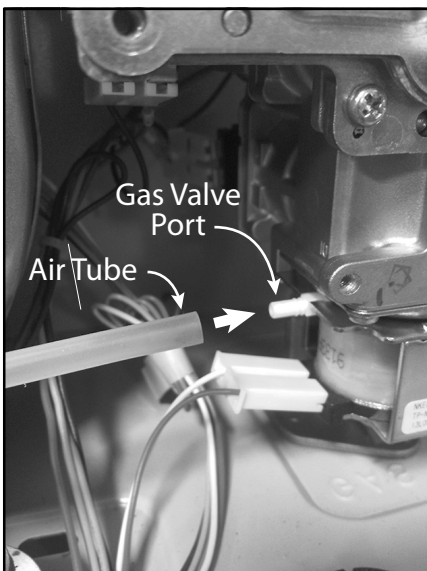

- 9.5 Attach the air tube from the bottom of the combustion chamber to the port on the left side of the gas valve (Figure 80).
- 9.6 Secure the power cord to the gas valve as shown in Figure 24 on page 35. (See the “Power Cord Mounting Tab” callout.) **Hand-tighten only.**
- Use the mounting tab and the M4X10 screw.
 - The mounting hole is located on the left side of the gas valve.
- 9.7 Line up the manifold plate with the holes on the burner and combustion box. Insert and hand tighten the top center screw on the manifold plate. (See “Manifold Plate,” page 35.)
- 9.8 Hand tighten the remaining manifold plate screws. **Do not overtighten.**

10. Install the igniter assembly (item 709, p. 69) to the lower, right-hand corner of the manifold plate.

- 10.1 Insert the screw and hand tighten it.
- 10.2 Slide the black igniter wire onto the igniter rod.

11. Install the fuse box. (See items 703 & 120, page 68. See also).

12. Hook up the freeze protection heater wiring:

- 12.2.1 At the top of the fuse box location, connect two plugs and receptacles as described in Figure 81.

NOTE: All connectors with yellow wires are connected to the same circuit, so the order in which you connect them does not matter.

- 12.2.2 Below the fuse box location, connect three plugs and receptacles as shown in Figure 82.

Figure 81.

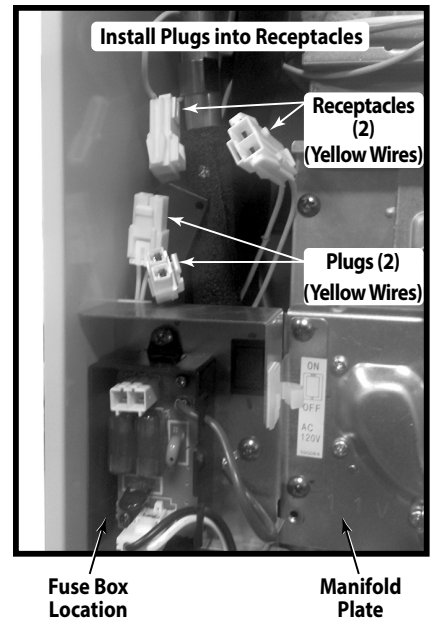
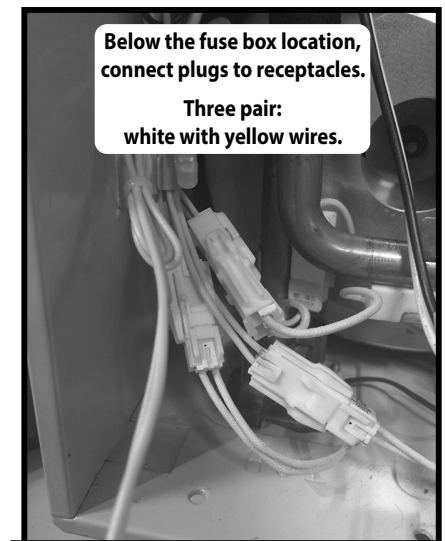

Figure 82.



Secure these wires with the cable clamp on the left side of the cabinet.

- 12.1 Install the fuse box assembly on the left side of the manifold plate. (See items 703 & 120, page 68.) Hand tighten two screws to secure it to the manifold plate.

13. Install the computer board (PCB):

- Small feet at the bottom must fit into the corresponding holes in the case.
- Insert the screw at the top of the computer board, then hand-tighten it to secure the board to the fuse box assembly. See item 701, page 68.

- 13.1 Connect all of the wires to the computer board. All of the wire connectors are uniquely sized and shaped to fit only in the correct connector on the board. **Refer to the schematic on page 22.**

NOTE:

- Indoor Models: There are two (2) receptacles on the computer board that will be open (Figure 83).

Outdoor Models: There are three (3) receptacles on the computer board that will be open (Figure 83).

- Item "I" in the schematic (p. 22) uses a separate wiring assembly which includes three wires: yellow, green, and orange.) Install it as shown in the schematic.

- 13.2 Insert the connector from the power supply cable to the top port on the fuse box. If needed, refer to Figure 75, page 60.

- 13.3 Use screws to secure three (3) green wires to the bottom, center of the manifold plate. See "Ground Connections" in Figure 24, page 35. (There are two mounting holes for these wires.)

The three green wires can be identified as follows:

- One green wire comes from the power cord.
- Two green wires come from connectors on the computer board.

14. Complete the wiring connections inside the cabinet:

- Locate the plug and receptacle with **blue** wires. Plug them together.
- Locate the plug and receptacle with **yellow** wires. Plug them together.

15. INDOOR MODELS ONLY: Plug the wires from the temperature controller (item 721, p. 67) to the matching wires from the computer board. (These wires are black and white).

16. Verify that all water connections are tight and that there are no parts left over.

17. Restore power to the water heater.

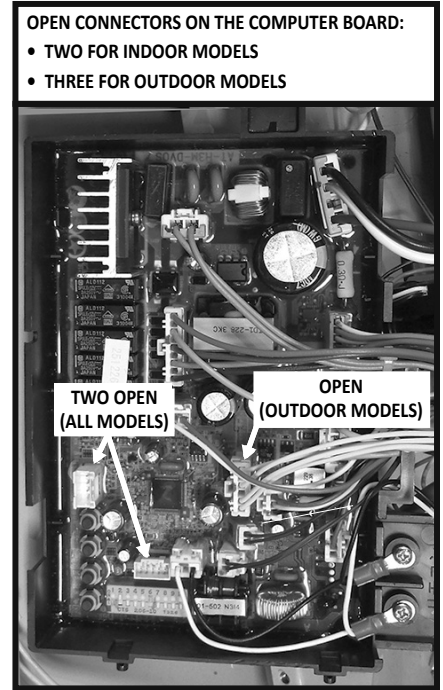

Figure 83.

18. Open the gas valve slowly and check for leaks. If any gas leaks appear, shut off the gas and disconnect power to the water heater.

19. Turn on water to the heater and test for proper operation.

20. Verify that there are no water or gas leaks.

21. INDOOR MODELS: Insert the temperature controller into the opening of the front cover, then reinstall the front cover.

OUTDOOR MODELS: Reinstall the front cover.

If you have any questions, please contact technical support.

This page is intentionally left blank. The Components section begins on the following pages.

This page is intentionally left blank. The Components section begins on the following page.

COMPONENT DIAGRAMS/ITEM NUMBERS

Case assembly

Indoor model

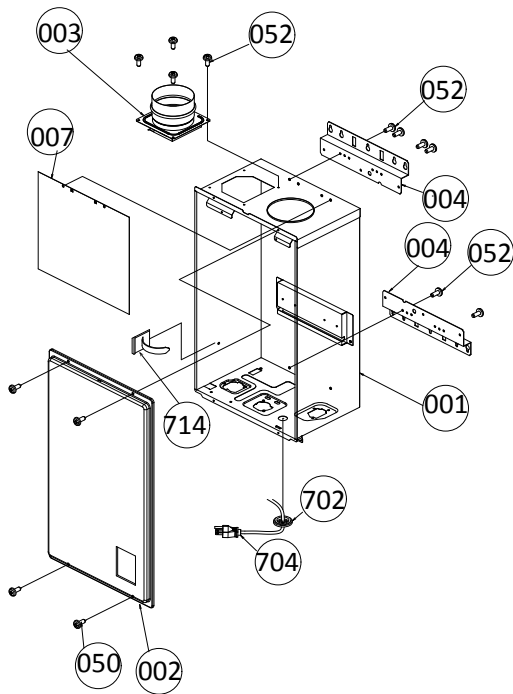

Outdoor model

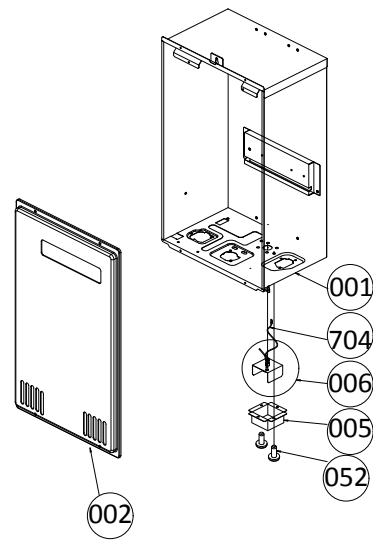

Temperature remote controller

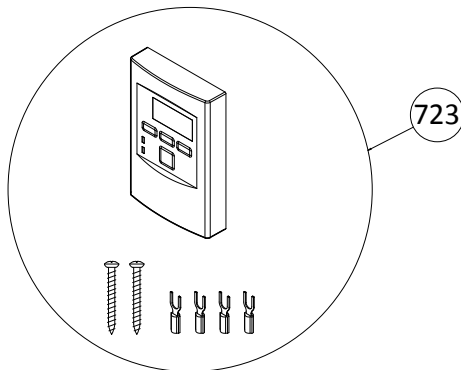

Temperature controller

Indoor model

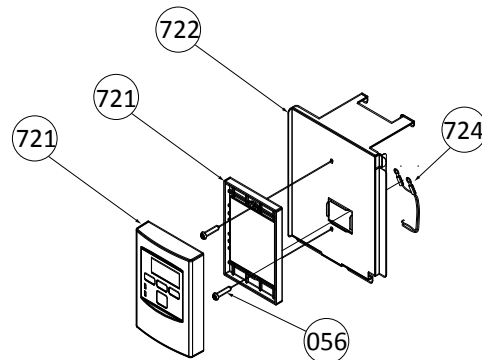

COMPONENT DIAGRAMS/ITEM NUMBERS

Computer board assembly

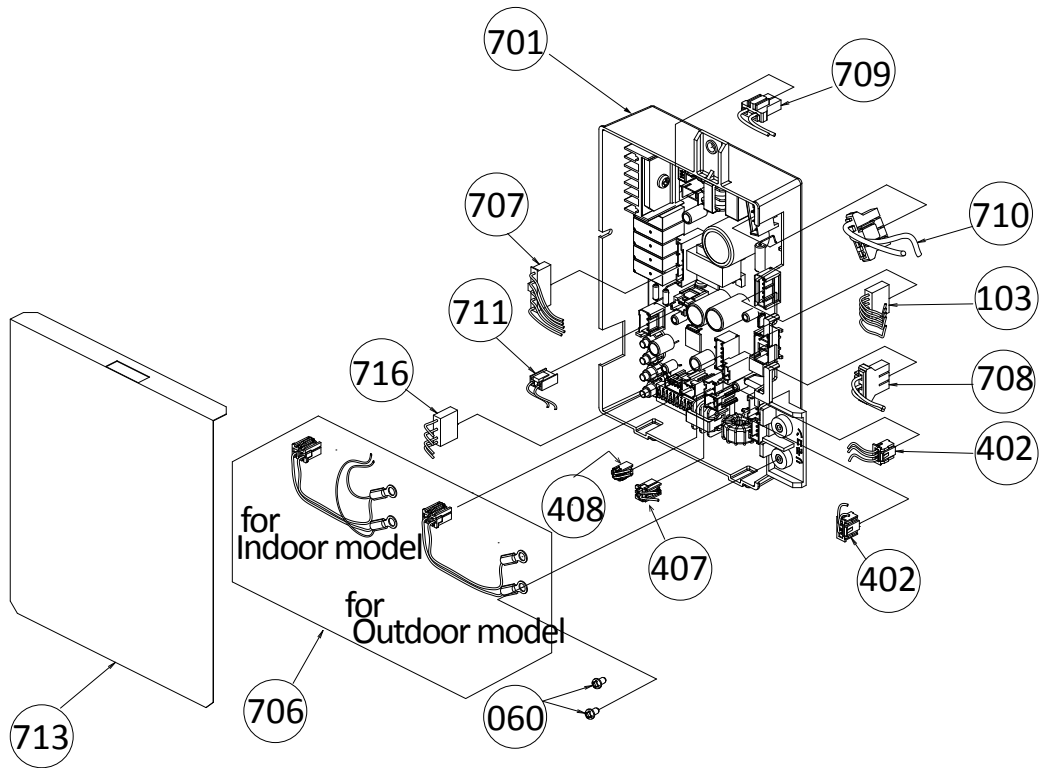

Fuse box assembly

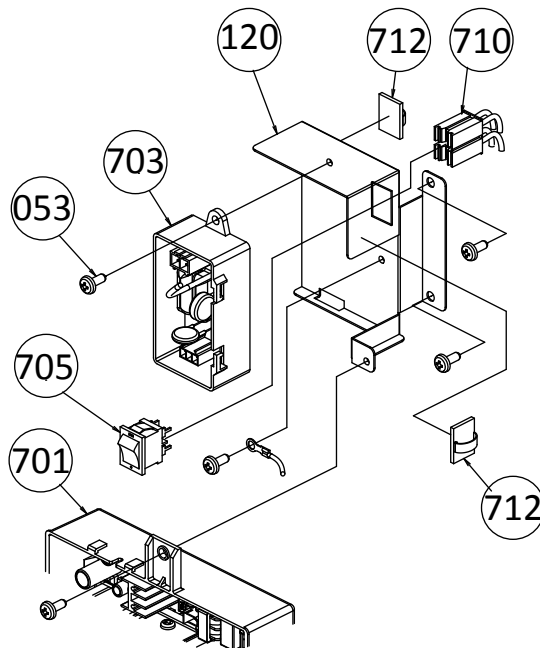

COMPONENT DIAGRAMS/ITEM NUMBERS

Burner assembly

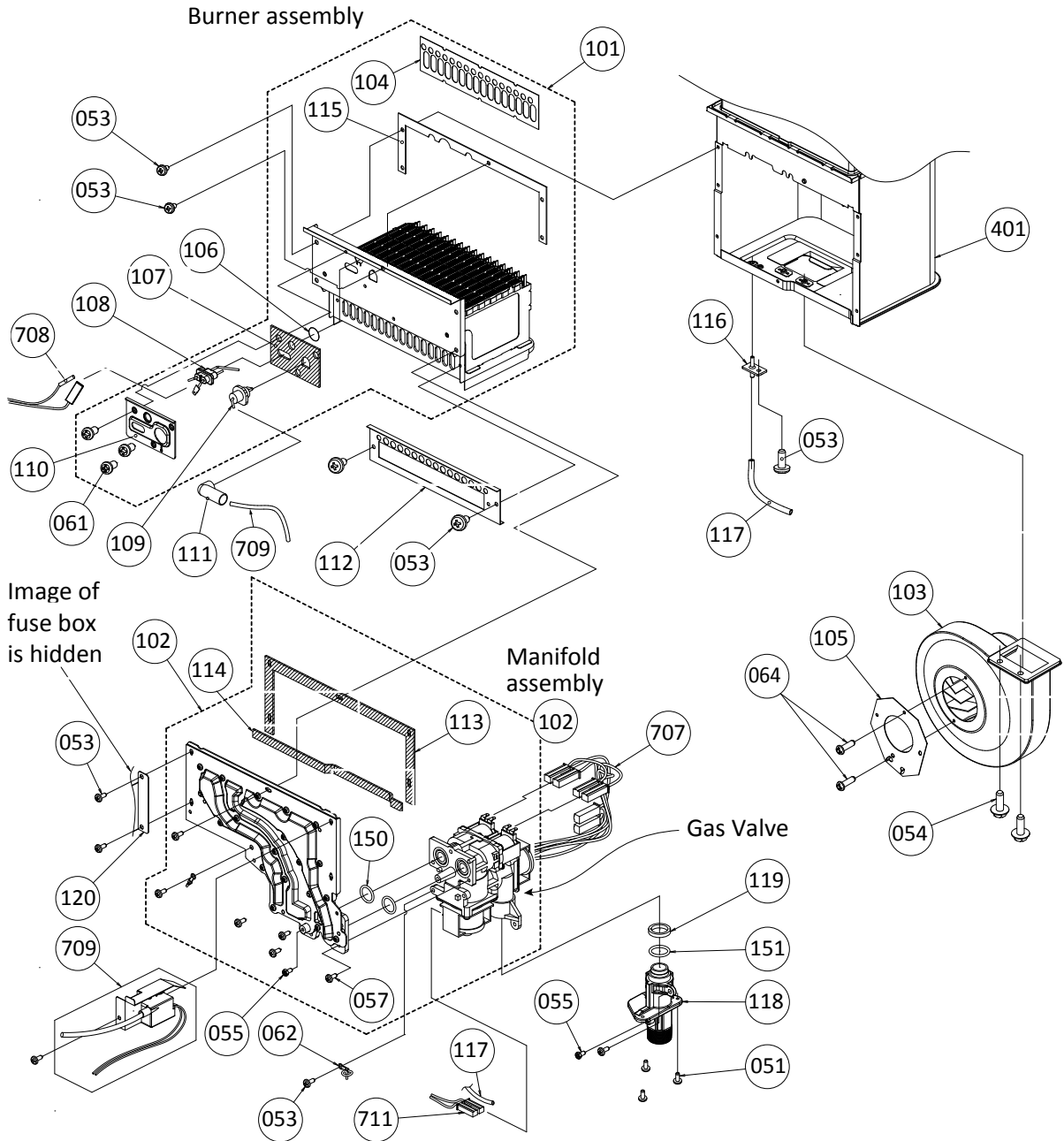

COMPONENT DIAGRAMS/ITEM NUMBERS

Waterway Assembly

Indoor Model

Outdoor Model

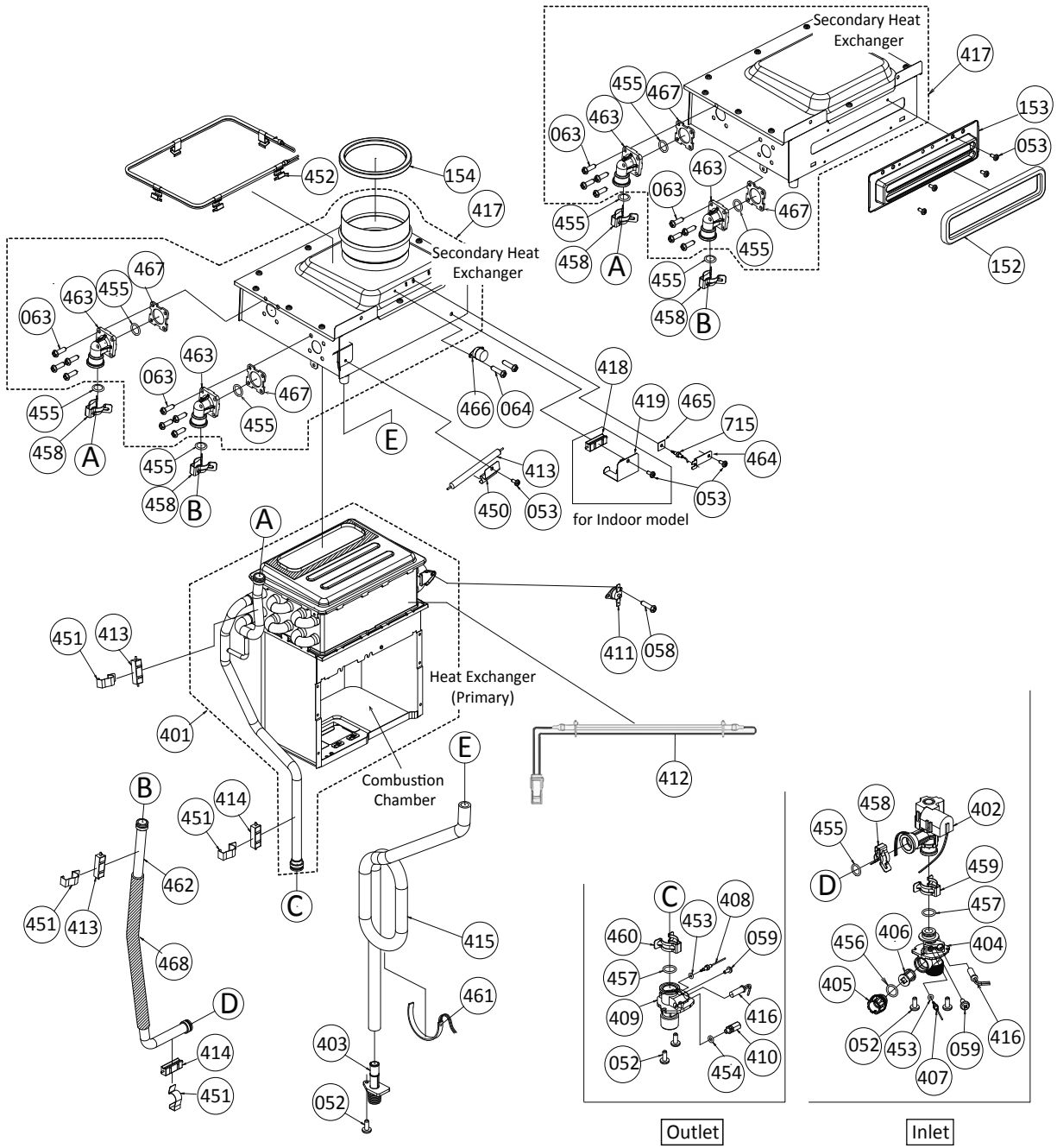

COMPONENTS



COMPONENT ITEM NUMBERS

Table 10: Component Descriptions and Part Numbers

Item Number	Description	Part Number	
		140 Model	T-H3M Model
001	Case assembly for Indoor model	N/A	EK450
	Case assembly for Outdoor model	N/A	EK451
002	Front cover for Indoor	N/A	EK452
	Front cover for Outdoor	N/A	EK453
003	Intake air port assembly	320273-350	EK454
004	Bracket	N/A	EK455
005	Junction box	319143-510	EK190
006	Power supply cord assembly	320273-352	EK456
007	Back guard panel	N/A	EK457
050	Screw M4×12 (W/ Washer)	319143-025	EW000
051	Screw M4×10 (W/ Washer)	319143-325	EW001
052	Screw M4×10 (Coated)	319143-026	EW002
053	Screw M4x10	319143-060	EW003
054	Hex head screw M4×12 (W/Washer)	319143-326	EW004
055	Hex head screw M4x8	319143-063	EW005
056	Pan screw M4X20	N/A	EW018
057	Tap tight screw M4x12 FEZN	319143-201	EKK31
058	Screw M3x6 SUS	319143-087	EW00A
059	Screw M4x6	319143-328	EW009
060	Screw M3x6	N/A	EK191
061	Pan screw M4x8	319143-059	EW00D
062	Wire clamp 60	319143-048	EM167
063	Screw M4x10	320273-497	EW00P
064	Screw M3x6 SUS3	319143-330	EW00B
101	Burner assembly	320273-353	EK458
102	Manifold with gas valve assembly LP	320273-354	EK459
	Manifold with gas valve assembly NA	320273-356	EK460

COMPONENT ITEM NUMBERS

Table 10: Component Descriptions and Part Numbers

Item Number	Description	Part Number	
		140 Model	T-H3M Model
103	Fan motor for Indoor model	319143-443	EK109
	Fan motor for Outdoor model	319143-043	EKK25
104	Burner gasket	319143-031	EKK2X
105	Fan damper for Indoor model	320273-557	EK491
	Fan damper for Outdoor model	319143-282	EM381
106	Burner window	319143-033	EKK2V
107	Rod holder gasket	319143-034	EKK2W
108	Flame rod	319143-517	EK193
109	Igniter rod	320273-357	EK461
110	Rod holder	319143-036	EKK32
111	Rod cap	320273-358	EK462
112	Burner damper Indoor	320273-359	EK463
	Burner damper Outdoor	320273-360	EK464
113	Manifold gasket A	319143-044	EKK2Y
114	Manifold gasket B	319143-045	EKK2K
115	Burner holder gasket	319143-032	EKK0G
116	Pressure port	319143-042	EKK2D
117	Combustion chamber tube	319143-344	EX019
118	Gas inlet	320273-362	EK465
119	Gas inlet ring	319143-049	EKK2Z
120	Surge box plate	N/A	EK466
150	O-ring P18 NBR (Black)	319143-350	EZP18
151	O-ring P20 NBR (Black)	319143-057	EK042
152	Silicon ring for Outdoor model	319143-370	EK442
153	Exhaust port for Outdoor model	319143-121	EX13J
154	Silicon ring	319143-065	EKN50
401	Heat exchanger assembly for 140 Indoor and Outdoor	320273-556	EK467

COMPONENT ITEM NUMBERS

Table 10: Component Descriptions and Part Numbers

Item Number	Description	Part Number	
		140 Model	T-H3M Model
402	Flow Sensor/ Control Valve	319143-463	EK129
403	Condensate drain port	319143-018	EKH23
404	Water inlet	319143-193	EKK1U
405	Inlet drain plug	319143-197	EKK2B
406	Inlet water filter	319143-198	EKK2C
407	Inlet thermistor	319143-214	EKK4J
408	Outlet thermistor	319143-529	EK207
409	Water outlet	319143-466	EK104
410	Outlet drain plug	319143-199	EKK2E
411	High Limit switch	319143-228	EM212
412	Overheat-cut-off fuse	319143-067	EX02A
413	Pipe heater	320273-364	EK468
414	Inlet heater	320273-365	EK469
415	Drain tube	320273-366	EK470
416	Inlet heater	319143-468	EK105
417	Secondary heat exchanger for Indoor model	320273-553	EK471
	Secondary heat exchanger for Outdoor model	320273-554	EK472
418	Secondary heat exchanger heater	320273-367	EK473
419	Heater fixing plate	N/A	EK474
450	Pipe heater fixing plate	N/A	EK475
451	Heater fixing plate 16	319143-125	EK031
452	Fuse fixing plate	N/A	EK476
453	O-ring P4 FKM	319143-082	EZF04
454	O-ring P6 FKM	319143-080	EZF06
455	O-ring P14 FKM	319143-100	EZF14
456	O-ring P15 FKM	319143-091	EZF15
457	O-ring P16 FKM	319143-083	EZF16
458	Fastener "14-22"	319143-105	EKK24
459	Fastener "16A"	319143-226	EM192
460	Fastener "16-25A"	319143-205	EKK39

COMPONENT ITEM NUMBERS

Table 10: Component Descriptions and Part Numbers

Item Number	Description	Part Number	
		140 Model	T-H3M Model
461	Flat heater	319143-535	EK217
462	Cold pipe for 140 model	320273-555	EK477
463	Header connection	320273-368	EK478
464	Thermistor fixing plate	319143-106	EX13H
465	Exhaust thermistor gasket	319143-111	EX13L
466	High limit switch for exhaust	319143-104	EKH6G
467	Gasket	319143-542	EK229
468	Inlet pipe packing	320273-558	EK479
701	Computer board	320273-369	EK480
702	Rubber grommet	319143-426	EX148
703	Surge box	320273-128	EK280
704	120 VAC wire for Indoor model	319143-427	EK146
	120 VAC wire for Outdoor model	319143-546	EK143
705	120 VAC Power ON-OFF switch	319143-141	EKK4V
706	Remote controller wire for Indoor model	320273-376	EK481
	Remote controller wire for Outdoor model	319143-473	EK138
707	Gas valve wire	320273-379	EK482
708	Flame rod wire	320273-380	EK483
709	Igniter assembly	320273-381	EK484
710	Freeze protection thermostat	319143-185	EKJ59
711	Proportional gas valve wire	319143-481	EK112
712	Nylon clamp FC6	N/A	EX004
713	Computer board cover	319143-191	EKK1M
714	Cable clamp for Indoor model	319143-500	EX13C
715	Exhaust thermistor for Indoor model	319143-131	EKH6E

COMPONENT ITEM NUMBERS

Table 10: Component Descriptions and Part Numbers

Item Number	Description	Part Number	
		140 Model	T-H3M Model
716	Exhaust high limit switch wire	319143-501	EK180
721	Temperature controller for Indoor model	320273-684	EK487
722	Fixing plate	N/A	EK490
723	Temperature remote controller	319143-485	TM-RE40
724	Remote controller connection wire	320273-512	EK489

