



# Residential / Commercial Gas Tankless Water Heaters

## Tankless Non-Condensing Water Heaters

Fully modulating, gas fired, tankless water heater specifically designed for residential and commercial applications. Supplies hot water to domestic hot water systems and can be used with water storage tanks, recirculation systems, and/or combined domestic & heating applications.

### FEATURES:

**MAXIMUM FLOW RATES UP TO 10.0 GPM**

**AVAILABLE IN NATURAL GAS OR PROPANE (LP)**

**OUTDOOR MODELS INCLUDE REMOTE CONTROL AS A STANDARD FEATURE**

**INDOOR MODELS INCLUDE BOTH A REMOTE CONTROL AND POWER CORD AS STANDARD FEATURES**

**LOW NO<sub>x</sub> EMISSIONS**

**COMPLIES WITH LEAD FREE STANDARDS**

**HEAT EXCHANGER (T-D2 MODELS) IS CONSTRUCTED OF COMMERCIAL GRADE COPPER**

### SAFETY FEATURES:

- Built in Freeze Protection
- Manual Reset Hi-Limit
- Overheat Cutoff Fuse
- Inlet and Outlet Thermistors for Constant Temperature Monitoring
- Flame Sensor

**EASY-LINK UP TO 4 UNITS (T-D2 MODELS):**

- With no additional parts or accessories needed

### VENTING AND COMBUSTION

- 4" Category III Vent
- Vertical or Horizontal Installation
- 50' Max Length, 5 Elbows max (90° elbows = 5' equivalent length)
- Power Vent Power Vent or Power Direct Vent
- Electronic Ignition - No Pilot Light
- 3" Combustion Air Intake (with optional kit)

### OPTIONAL ACCESSORIES

- Complete Line of Category III Venting
- Recess Box (outdoor models)
- Pipe Cover
- Direct Vent Conversion Kit (indoor models)
- Isolation Valve Kits
- Backflow Preventer
- Concentric Termination Kits

### WARRANTY

- 15-year limited warranty on heat exchanger in residential applications
- 6-year limited warranty on heat exchanger in commercial applications
- 5-year limited warranty on all parts

### INDOOR MODELS

TKJR2-IN, TK4-IN, TD2-IN



### OUTDOOR MODELS

TKJR2-OS, TK4-OS, TD2-OS



ANSI Z21.10

MODEL NUMBER	TYPE	GAS CONSUMPTION INPUT		INLET GAS PRESSURE		ENERGY FACTOR (EF)	MAXIMUM GPM*	HOT/COLD CONNECTIONS	GAS CONNECTION	DIMENSIONS IN INCHES			UNIT WEIGHT (LBS)
		MINIMUM BTU/H	MAXIMUM BTU/H	MINIMUM IN. W.C.	MAXIMUM IN. W.C.					HEIGHT	WIDTH	DEPTH	
<b>Indoor Models</b>													
<b>T-KJr2-IN-NG</b>	Natural	19,500	140,000	4.0	10.5	0.82	6.6	3/4" NPT	3/4" NPT	20-1/4	13-3/4	7-3/4	33
<b>T-KJr2-IN-LP</b>	Propane	19,500	140,000	8.0	14.0	0.82	6.6	3/4" NPT	3/4" NPT	20-1/4	13-3/4	7-3/4	33
<b>T-K4-IN-NG</b>	Natural	11,000	190,000	4.0	10.5	0.82	8	3/4" NPT	3/4" NPT	20-1/4	13-3/4	9-1/2	38
<b>T-K4-IN-LP</b>	Propane	11,000	190,000	8.0	14.0	0.82	8	3/4" NPT	3/4" NPT	20-1/4	13-3/4	9-1/2	38
<b>T-D2-IN-NG**</b>	Natural	11,000	199,000	4.0	10.5	0.82	10	3/4" NPT	3/4" NPT	20-1/4	13-3/4	9-1/2	39
<b>T-D2-IN-LP**</b>	Propane	11,000	199,000	8.0	14.0	0.82	10	3/4" NPT	3/4" NPT	20-1/4	13-3/4	9-1/2	39
<b>Outdoor Models</b>													
<b>T-KJr2-OS-NG</b>	Natural	19,500	140,000	4.0	10.5	0.82	6.6	3/4" NPT	3/4" NPT	20-1/4	13-3/4	7-3/4	33
<b>T-KJr2-OS-LP</b>	Propane	19,500	140,000	8.0	14.0	0.82	6.6	3/4" NPT	3/4" NPT	20-1/4	13-3/4	7-3/4	33
<b>T-K4-OS-NG</b>	Natural	11,000	190,000	4.0	10.5	0.82	8	3/4" NPT	3/4" NPT	20-1/4	13-3/4	9-1/2	38
<b>T-K4-OS-LP</b>	Propane	11,000	190,000	8.0	14.0	0.82	8	3/4" NPT	3/4" NPT	20-1/4	13-3/4	9-1/2	38
<b>T-D2-OS-NG**</b>	Natural	11,000	199,000	4.0	10.5	0.82	10	3/4" NPT	3/4" NPT	20-1/4	13-3/4	9-1/2	39
<b>T-D2-OS-LP**</b>	Propane	11,000	199,000	8.0	14.0	0.82	10	3/4" NPT	3/4" NPT	20-1/4	13-3/4	9-1/2	39

1.5-150 PSI water pressure. 40 PSI or above recommended for maximum flow.

\*Current numbers based on factory testing, 0.5 GPM required for activation, 0.4 GPM required for continuous fire after initial ignition.

\*\* Suitable for commercial applications.

Indoor models are certified from sea level to 6,000 ft. elevation. Outdoor models are certified from sea level to 6,000 ft. elevation.

### T-KJR2 INDOOR DIMENSIONS

**CLEARANCES:** TOP 12", BOTTOM 12", FRONT 24", BACK 1", SIDES 3"

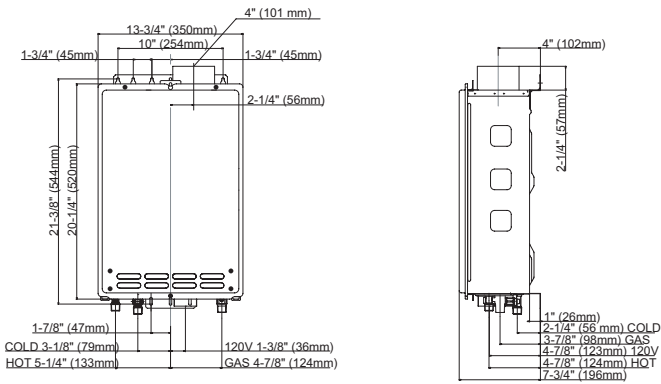

### T-KJR2 OUTDOOR DIMENSIONS

**CLEARANCES:** TOP 36", BOTTOM 12", FRONT 24", BACK 1", SIDES 3"

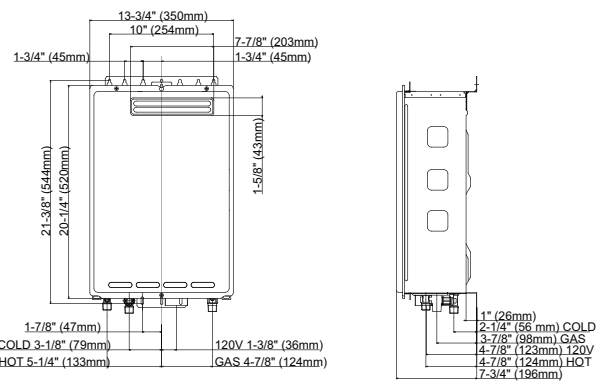

### T-K4 AND T-D2 INDOOR DIMENSIONS

**CLEARANCES:** TOP 12", BOTTOM 12", FRONT 24", BACK 1", SIDES 3"

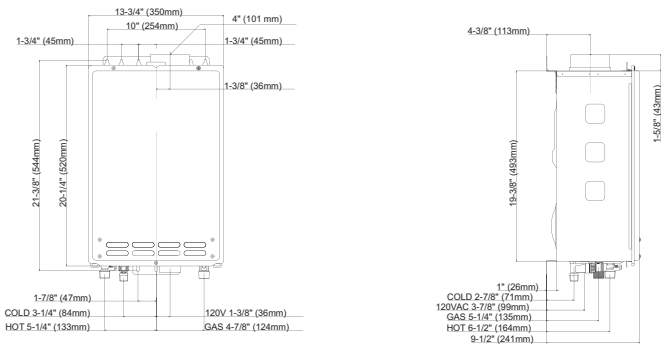

### T-K4 AND T-D2 OUTDOOR DIMENSIONS

**CLEARANCES:** TOP 36", BOTTOM 12", FRONT 24", BACK 1", SIDES 3"

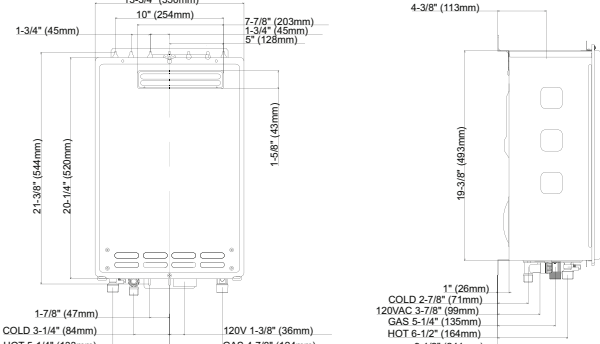

# Residential / Commercial Gas Tankless Water Heaters

## T-KJR2 MODELS

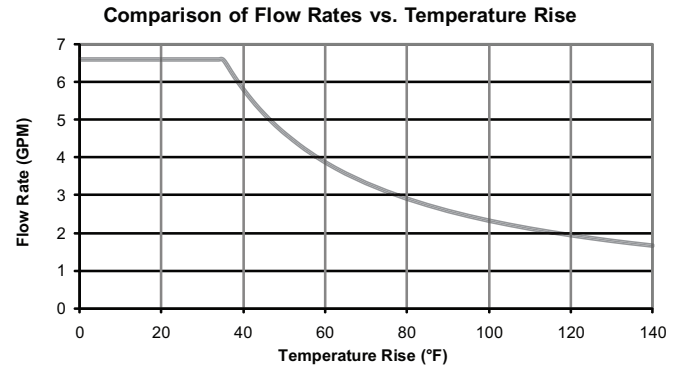
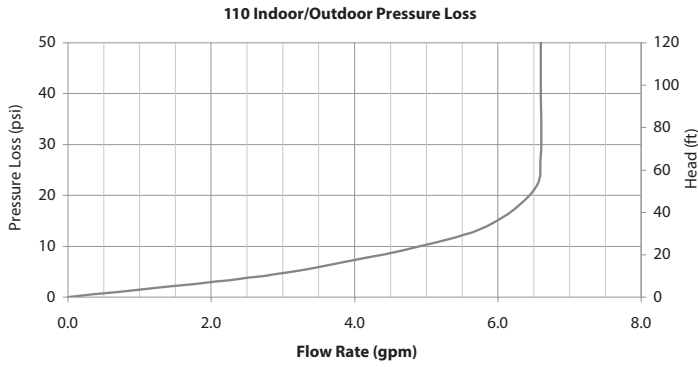

## T-K4 MODELS

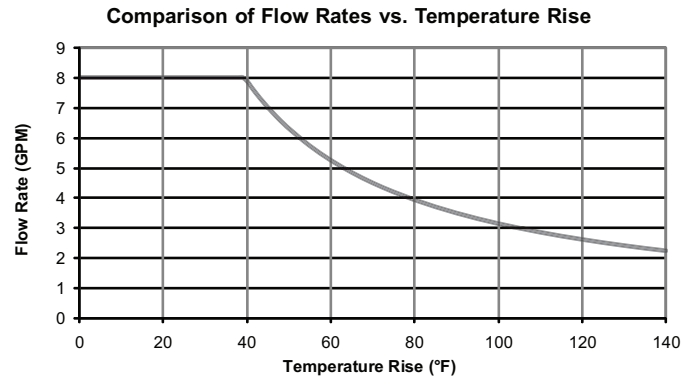
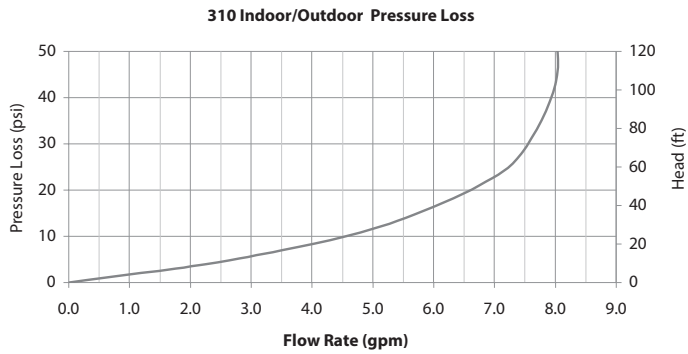

## T-D2 MODELS

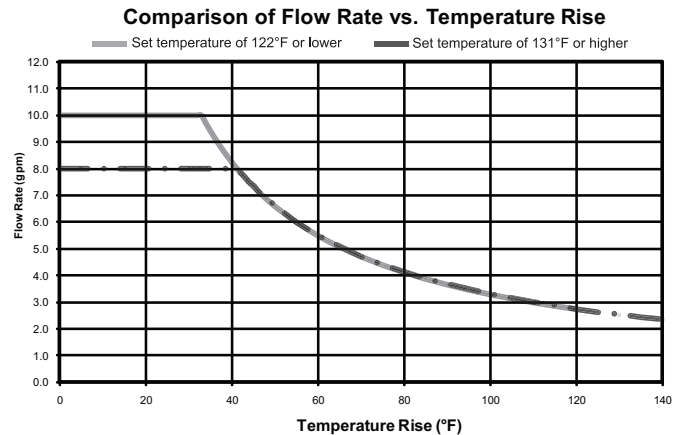
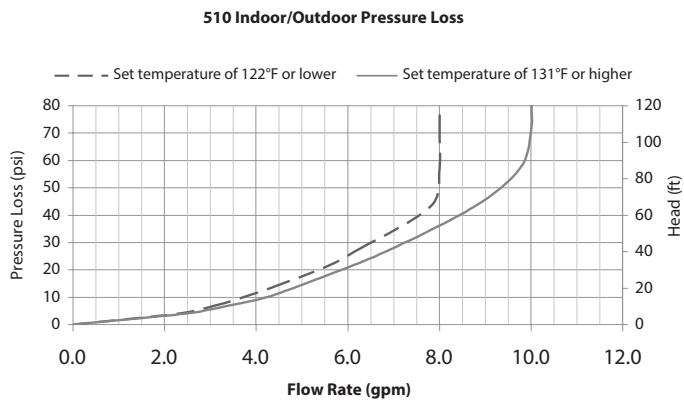



## Residential / Commercial Gas Tankless Water Heaters

### Specification for the T-D2-IN or T-D2-OS

The fully modulating, on-demand, gas fired tankless water heater shall be Takagi Tankless Water Heater model TD2-IN or TD2-OS, having a maximum input rating of 199,000 Btu/h and available in NG or LP. The heater shall have  $\frac{3}{4}$  in. male NPT water and gas connections. The inlet gas supply pressures shall be 4.0 in. WC (min.) up to 10.5 in. WC (max) for NG and 8.0 in. WC (min.) up to 14 in. WC (max.) for LP. The heater shall be supplied with a temperature remote, 9007603005, that can be installed up to 400 ft. from the heater using 20 gauge (minimum) control wire. The temperature remote shall provide diagnostic information, fault history, and heater set temperature. The heater shall operate using 120 V / 60 Hz power source. The indoor heater will incorporate a factory installed power cord.

The indoor heater shall be vented with 4" diameter Category III vent pipe with a length not to exceed 50 ft. (equivalent), terminating horizontally or vertically. The indoor heater can be direct vented with optional direct vent conversion kit, 9007667005, using 3" diameter air intake pipe. The intake pipe may use material such as PVC, ABS, aluminum, or Category III pipe and cannot exceed 50 ft. (equivalent) length. The outdoor heater shall be constructed with an integral exhaust vent on the front of the heater.

The water heater shall use a commercial grade copper alloy, fin tube heat exchanger with quick release brass or bronze waterways. The heater shall be controlled by an onboard solid-state printed circuit board which uses the following factory installed components: thermistors to monitor inlet and outlet water temperature; a flow sensor to measure flow rate; a flame sensor to monitor combustion; an Air-Fuel Ratio Rod to measure and adjust operation in order to maintain optimal combustion efficiency. The heater also consists of inline fusing and surge absorbers for electrical surge protection, an electronic spark igniter, aluminized stainless steel burners, a hi-limit temperature switch, modulating gas valve, an overheat cutoff fuse, ceramic heating blocks to protect the heat exchanger and water piping. The indoor heater shall incorporate auto-fire system for additional freeze protection.

The heater can manifold to Easy-Link up to 4 heaters to provide additional capacity. The Easy-Link controls shall be built onto the onboard solid-state printed circuit board and does not require external controls. The linking control wire shall be supplied with the heater. The Easy-Link control shall modulate the system for the most efficient performance. The Easy-Link control shall rotate the priority heater every 12 hours of operation time or 100 starts for balanced duty/cycle operation.

The heater shall be design certified by CSA according to ANSI Z21.10.3, approved for sale in the United States, have a minimum energy factor of 0.82, meets the energy efficiency requirements of the U. S. Department of Energy and ASHRAE 90.1, complies with Low NOx emissions of 40 ng/J or 55 ppm, and shall be certified by NSF to NSF/ANSI 5 Standard.