



Product Preservers® Anti-Scale System Chemical-Free, Salt-Free Scale Prevention

Flow Rates: From 0.25 gpm to 10 gpm (1.0 - 38 lpm)

The Product Preservers® Anti-Scale System provides protection from scale formation on internal and external plumbing surfaces. The Product Preservers® system is a single cartridge based system that must be installed on a cold water line prior to a single water-heating device (water heater or tankless water heater).

Product Preservers® prevents scale by transforming dissolved hardness minerals into harmless, inactive microscopic crystal particles through Template Assisted Crystallization (TAC). These crystals stay suspended in the water and are passed to drain. The system requires very little maintenance, no backwashing, no salt, and no electricity. Typical hardness problems, especially buildup of scale in heating elements, pipes, water heaters, boilers, and on fixtures, are no longer a concern.

Product Preservers® is not a water softener. It does not add chemicals. It is a scale prevention device with proven third party laboratory test data and years of successful commercial, residential, and food service applications. Product Preservers® is the intelligent scale solution and is a great alternative to water softening (ion-exchange) or scale sequestering devices.

Features

- Models available to cover flow rates from 0.25 gpm to 10 gpm (1.0 - 38 lpm)
- Chemical-free scale prevention and protection — converts hardness minerals to harmless, inactive microscopic crystals making Product Preservers® an effective alternative to ion-exchange water softeners for the prevention of scale due to water hardness
- Virtually maintenance free — No salt bags or other chemicals to constantly add or maintain
- No control valve, no electricity, and no wastewater
- Uses environmentally friendly "green" technology
- Improves efficiency of all water heating devices and downstream plumbing components
- Simple sizing & installation — standard 3/4" connections
- Perfect system for restaurants, cafeterias, coffee shops, and homes where multiple or single equipment protection is desired for longer equipment life and reduced energy consumption
- Inlet ball valve for easy isolation shutoff and filter changes
- Product Preservers® cartridge based systems are easily maintained; change the cartridge once every two years
- Easily installed mounting bracket included w/filter wrench to allow cartridge change-outs when necessary

*The wetted surface of this product contacted by consumable water contains less than one quarter of one percent (0.25%) of lead by weight.

*Not for use on closed loop systems.



Models

Model	Part Number	Peak Flow Rate	Connection Size
SM1.0L	323631-002	6 gpm (23 lpm)	3/4" (20mm)
LG1.5L	323631-000	10 gpm (38 lpm)	FNPT

Replacement Cartridge

Model	Replacement Cartridge	Part Number	Replacement Schedule
SM1.0L	SM1.0L-RM	323631-003	Every 2 years
LG1.5L	LG1.5L-RM	323631-001	

Capacity: Product Preservers® cartridge does not have a grain removal capacity, however, other contaminants present in the water will gradually degrade the effectiveness of this cartridge. Change the Product Preservers® cartridge at least once every two years.

Specifications

A Product Preservers® Anti-Scale System shall be installed on the cold water service line to condition the tap water just prior to the service line feeding the equipment it is designed to protect. The unit will be sized for maximum or peak flow rate based on the specification of said equipment. A Product Preservers® system may also be installed to protect multiple pieces of equipment from the ill-effects of hard water scale provided the aggregate peak flow rate for each piece of equipment it is protecting has been considered. The system shall be plumbed with a bypass valve to allow isolation of filter housing to allow the bypass of untreated water in the event that service or cartridge replacement be necessary. The installation area should be suitable in size for the housing to be serviced without encumbrance and the system should be installed per the Installation, Operation, and Maintenance manual as provided with each system.

The Product Preservers® system must not require additional wastewater to backwash, flush, or regenerate once put into service. The system shall not require any chemical additives and shall not require electricity for operation.

Note: Copper oxide from new copper pipes can foul Product Preservers® media and leave system unprotected. If using new copper lines in installation, run system for **4 WEEKS WITHOUT CARTRIDGE INSTALLED** to allow lines to passivate.

System Specifications

Model	SM1.0L	LG1.5L
Peak Flow Rate	6 gpm (23 lpm)	10 gpm (38 lpm)
Service Flow Rate	0.25 - 4 gpm (1 - 15 lpm)	0.5 - 10 gpm (1.9 - 38 lpm)
Gallon Rating for Cartridge	Up to 4 gpm, 24/7/235 for 2 years	Up to 6 gpm, 24/7/365 for 2 years
Maximum Pressure	90 psi (6.2 bar)	
Temperature	35°F - 100°F (2°C - 38°C)	
Inlet/Outlet Connections	3/4" FNPT	

Water Chemistry & Limitations

pH	6.5 to 8.5
Hardness (maximum)	75 grains (1300 ppm CaCO ₃)
Chlorine	<3 ppm
Iron (maximum)	0.3 mg/l
Manganese (maximum)	0.05 mg/l
Copper	none allowed
Oil & H ₂ S	none allowed
Polyphosphate	none allowed
Silica (maximum)	10 ppm

Standards

Independent scientific testing has confirmed that Template Assisted Crystallization (TAC) technology provides scale reduction of over 95+%.

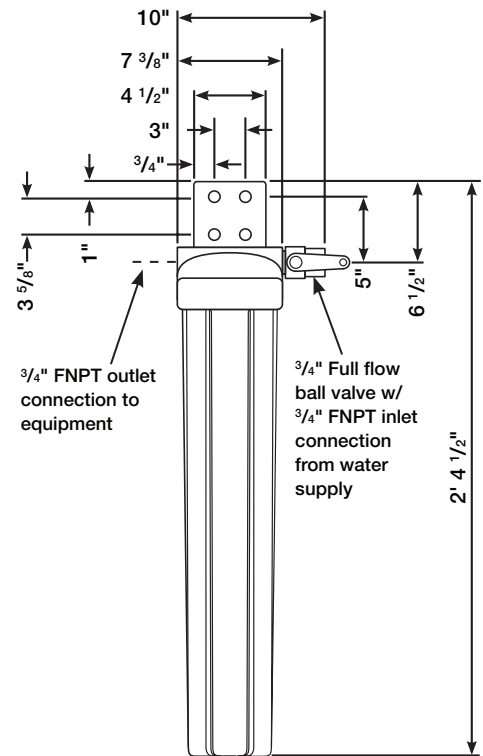
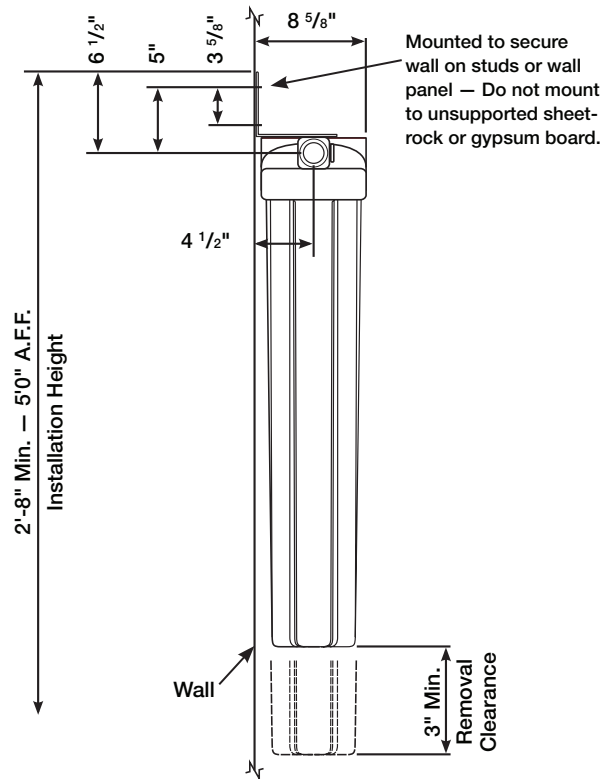

Model	Sump Color	Weight
SM1.0L	Blue	15 lbs (6.8 kg)
LG1.5L	White	19 lbs (8.6 kg)

*Note: Both models have same external dimensions.

USA: 500 Tennessee Waltz Parkway, Ashland City, TN 37015