

13. Components diagrams

Case assembly

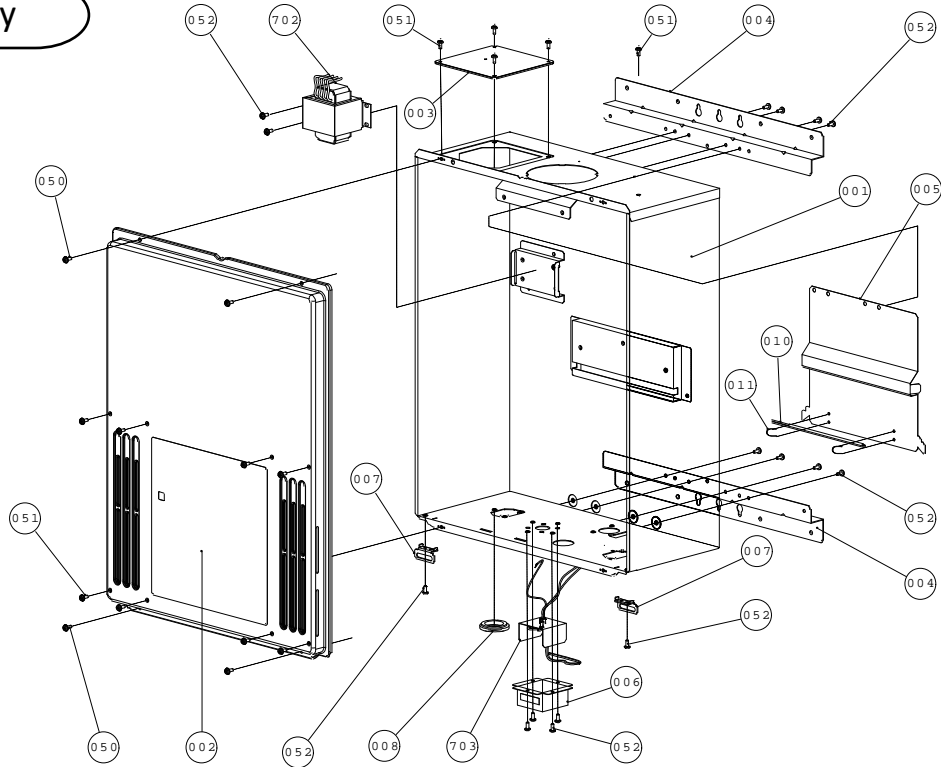

Computer board assembly

Other than Part# 706, the T-M32 and the T-M32 ASME share the same components.

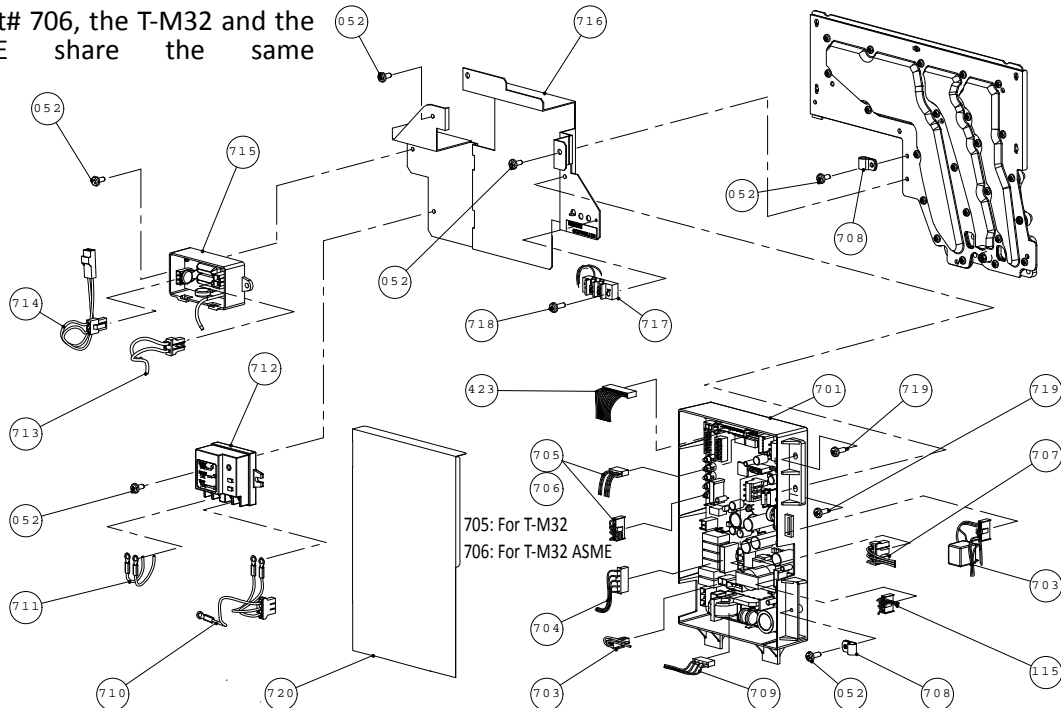

Water way assembly

Other than Part# 211, Part#439, Part#440 and Part# 441, the T-M32 and the T-M32 ASME share the same components.

T-M32

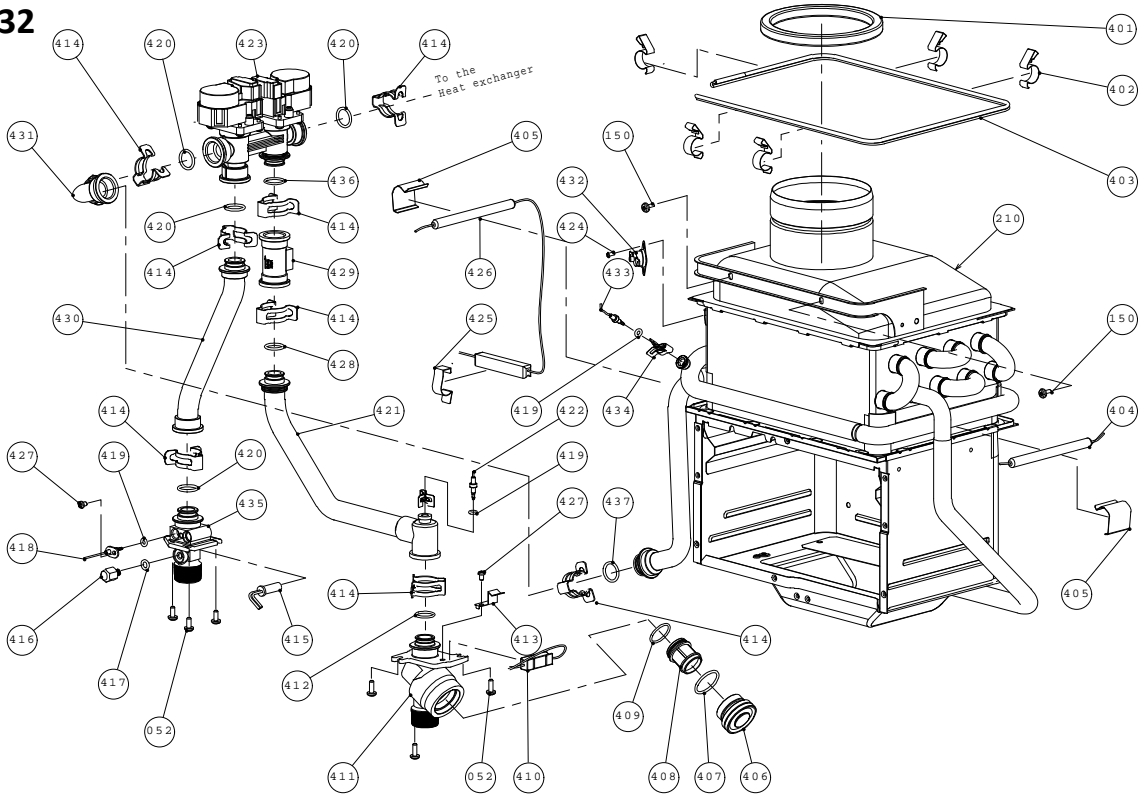

T-M32 ASME

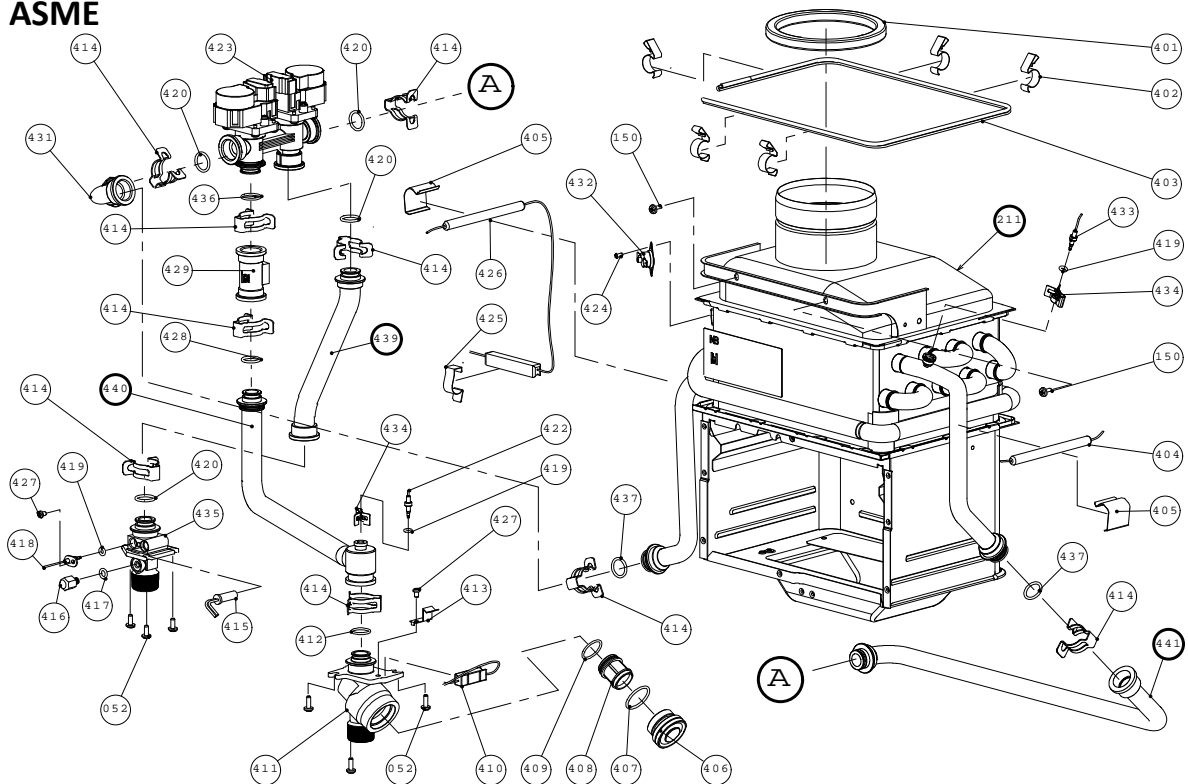

14. Parts list

Item #	Part #	Description	Common parts for other models
1	EM389	Case assembly	
2	EM431	Front cover	
3	EM386	Air blockage plate	
4	EM104	Bracket	
5	EM384	Back guard panel	
6	EKJ64	Junction box	T-K3, T-K3-Pro, T-K3-SP/OS, T-H2-DV/OS, T-KJr2-IN/OS, T-K4-IN/OS, T-D2-IN/OS, T-M50
7	EX00E	Fixing plate	
8	EX00B	Rubber bush	T-M50
10	EM484	Overheat-cut-off-fuse for combustion chamber	T-H2-DV/OS
11	EKK22	Fastener	T-H2-DV/OS
51	EW001	Screw M4×10 (W/Washer)	*
52	EW002	Screw M4×10 (Coated)	*
101	EM410	Burner assembly	
102	EM411	Burner gasket	
103	EM412	Guide plate gasket	
104	EKK2V	Burner window	T-K3, T-K3-Pro, T-K3-SP/OS, T-H2-DV/OS, T-KJr2-IN/OS, T-K4-IN/OS, T-D2-IN/OS, T-M50
105	EKK2W	Rod holder gasket	T-K3, T-K3-Pro, T-K3-SP/OS, T-H2-DV/OS, T-KJr2-IN/OS, T-K4-IN/OS, T-D2-IN/OS, T-M50
106	EKK0E	Flame rod	T-K3, T-K3-Pro, T-K3-SP/OS, T-H2-DV/OS, T-K4-IN/OS, T-D2-IN/OS, T-M50
107	EKK32	Rod holder	T-K3, T-K3-Pro, T-K3-SP/OS, T-H2-DV/OS, T-K4-IN/OS, T-D2-IN/OS, T-M50
108	EKK0F	Igniter rod	T-K3, T-K3-Pro, T-K3-SP/OS, T-H2-DV/OS, T-K4-IN/OS, T-D2-IN/OS, T-M50
109	EKN61	Rod cap	T-K3, T-K3-Pro, T-K3-SP/OS, T-H2-DV/OS, T-KJr2-IN/OS, T-K4-IN/OS, T-D2-IN/OS, T-M50
110	EX01Z	High voltage ignite cable	

Item #	Part #	Description	Common parts for other models
110	EX01Z	High voltage ignite cable	
111	EM409	Damper	
112	EX02C	Urethane tube	
113	EKK2D	Pressure port	T-K3, T-K3-Pro, T-K3-SP, T-H2-DV/OS, T-K4-IN/OS, T-D2-IN/OS, T-M50
114	EM379	Fan motor fixing plate	
115	EKK25	Fan motor	T-K3, T-K3-Pro, T-K3-SP, T-H2-DV/OS, T-K4-IN/OS, T-D2-IN/OS, T-M50
116	EM381	Fan damper	
117	EKJ59	Freeze protection thermostat	T-K3, T-K3-Pro, T-K3-SP, T-KJr2-IN/OS, T-K4-IN/OS, T-D2-IN/OS
118	EM435	Manifold gasket A	
119	EX00F	Manifold gasket B	
120	EM440	Manifold assembly with gas valve assembly LP	
	EM441	Manifold assembly with gas valve assembly NA	
121	EM167	Wire cramp 60	T-K3, T-K3-Pro, T-K3-SP/OS, T-H2-DV/OS, T-KJr2-IN/OS, T-K4-IN/OS, T-D2-IN/OS, T-M50
122	EX00D	Gas inlet ring	
123	EM442	Gas inlet	
124	EKK1B	Igniter plate	T-K3, T-K3-Pro, T-K3-SP/OS, T-H2-DV/OS, T-KJr2-IN/OS, T-K4-IN/OS, T-D2-IN/OS, T-M50
125	EKN74	Igniter	T-K3, T-K3-Pro, T-K3-SP/OS, T-H2-DV/OS, T-KJr2-IN/OS, T-K4-IN/OS, T-D2-IN/OS, T-M50
151	EW00D	Pan screw M4×8	*
152	EW003	Screw M4×10	*
153	EW00H	Pan screw M4×12 (W/Washer)	*
154	EW00B	Screw M3×6	*
155	EW008	Screw M3×10	*
156	EZP26	O-ring P26 NBR (Black)	
157	EW006	Pan screw M4×10	*

Item #	Part #	Description	Common parts for other models
158	EW001	Screw M4×10 (W/Washer)	*
159	EW005	Hex head screw M4×8	*
160	EW00L	Pan screw M4×6 (W/Washer)	*
210	EM415	Heat exchanger assembly for T-M32	
211	EM45C	Heat exchanger assembly for T-M32 ASME	
401	EKN50	Silicon ring	T-K3, T-K3-Pro, T-K3-SP, T-H2-DV/OS, T-KJr2-IN/OS, T-K4-IN/OS, T-D2-IN/OS
402	EKK26	Fuse fixing plate 18	T-K3, T-K3-Pro, T-K3-SP/OS, T-H2-DV/OS, T-KJr2-IN/OS, T-K4-IN/OS, T-D2-IN/OS, T-M50
403	EM387	Overheat-cut-off-fuse	
404	EKN86	Pipe heater 122	T-M50
405	EKK27	Heater fixing plate	T-K3, T-K3-Pro, T-K3-SP/OS, T-H2-DV/OS, T-KJr2-IN/OS, T-K4-IN/OS, T-D2-IN/OS, T-M50
406	EM222	Filter plug	T-H2-DV/OS, T-M50
407	EZM25	O-ring P25 EPDM (Purple)	T-H2-DV/OS, T-M50
408	EX006	Water inlet filter	T-H2-DV/OS, T-M50
409	EZN21	O-ring JASO# 1021 EPDM (Purple)	T-H2-DV/OS, T-M50
410	EX002	Heater 101	T-H2-DV/OS, T-M50
411	EM404	Water inlet	T-H2-DV/OS
412	EZN16	O-ring JASO# 1016 EPDM (Purple)	T-H2-DV/OS
413	EX021	Heater plate	T-H2-DV/OS, T-M50
414	EX01H	Fastener "16AG"	T-H2-DV/OS, T-M50
415	EKK2P	Inlet heater	T-K3, T-K3-Pro, T-K3-SP/OS, T-H2-DV/OS, T-KJr2-IN/OS, T-K4-IN/OS, T-D2-IN/OS, T-M50
416	EK239	Outlet drain plug	T-H2-DV/OS
417	EZM06	O-ring P6 EPDM (Purple)	T-K3, T-K3-Pro, T-K3-SP/OS, T-H2-DV/OS, T-KJr2-IN/OS, T-K4-IN/OS, T-D2-IN/OS, T-M50
418	EX00H	Mixing thermistor	T-H2-DV/OS

Item #	Part #	Description	Common parts for other models
419	EZM04	O-ring P4 EPDM (Purple)	T-K3, T-K3-Pro, T-K3-SP/OS, T-H2-DV/OS, T-KJr2-IN/OS, T-K4-IN/OS, T-D2-IN/OS, T-M50
420	EZM16	O-ring P16 EPDM (Purple)	T-K3, T-K3-Pro, T-K3-SP/OS, T-H2-DV/OS, T-KJr2-IN/OS, T-K4-IN/OS, T-D2-IN/OS, T-M50
421	EM390	Cold pipe	
422	EKK38	Inlet thermistor	T-K3, T-K3-Pro, T-H2-DV/OS, T-D2-IN/OS, T-M50
423	EKH32	Water control valve	T-H2-DV/OS, T-M50
424	EW00A	Screw M3×6	*
425	EK031	Heater fixing plate 16	T-H2-DV/OS, T-KJr2-IN/OS, T-K4-IN/OS, T-D2-IN/OS, T-M50
426	EM45V	Pipe heater 212	
427	EW00L	Pan screw M4×6 (W/Washer)	
428	EZM15	O-ring P15 EPDM (Purple)	T-K3, T-K3-Pro, T-K3-SP/OS, T-H2-DV/OS, T-KJr2-IN/OS, T-K4-IN/OS, T-D2-IN/OS, T-M50
429	EKH33	Flow sensor	T-H2-DV/OS, T-M50
430	EM391	Hot pipe	
431	EM45G	L joint	
432	EKN34	Hi-limit switch	T-K3, T-K3-Pro, T-K3-SP/OS, T-H2-DV/OS, T-D2-IN/OS, T-M50
433	EKK2T	Output thermistor	T-K3, T-K3-Pro, T-H2-DV/OS, T-D2-IN/OS, T-M50
434	EKH30	Fastener "4-11"	T-K3, T-K3-Pro, T-H2-DV/OS, T-D2-IN/OS, T-M50
435	EKJ02	Water outlet	T-H2-DV/OS
436	EZN17	O-ring JASO# 1017 EPDM (Purple)	T-H2-DV/OS
437	EZM18	O-ring P18 EPDM (Purple)	T-M50
439	EM45E	Hot pipe for T-M32 ASME	
440	EM45D	Cold pipe for T-M32 ASME	
441	EM45F	Connection pipe for T-M32 ASME	
701	EM376	T-M32 PCB	
702	EM454	Transformer	
703	EM463	Junction box inner plate	
704	EM392	Gas valve wire	

Item #	Part #	Description	Common parts for other models
705	EM396	"Flow sensor, Gas proportional valve connection and Thermistors" wire	
706	EM479	"Flow sensor, Gas proportional valve connection and Thermistors" wire for T-M32 ASME	
707	EM395	Flame rod wire	
708	EC00X	Nylon clamp	T-K3, T-K3-Pro, T-K3-SP/OS, T-H2-DV/OS, T-KJr2-IN/OS, T-K4-IN/OS, T-D2-IN/OS
709	EM45T	Igniter & Freeze protection wire	
710	EM393	AC100V wire	
711	EM403	AC100V Transformer connecting wire	T-H2-DV/OS
712	EM207	Ground fault circuit interrupter	T-M50
713	EM400	Power supply code assembly	
714	EM399	AC120V Transformer connecting wire	
715	EM385	Surge box	T-M50
716	EM377	PCB fixing plate	
717	EM398	Remote controller terminal	
718	EW00X	Screw M3×12	
719	EX013	Screw M4×12	T-M50
720	EM478	PCB cover	