

13. Components diagrams

Case assembly

Other than the case assembly (No.15) and front cover (No.16), all of the T-H2-OS's parts are the same as the T-H2-DV. The T-H2-OS doesn't have fan motor for exhaust (No.124).

T-H2-DV

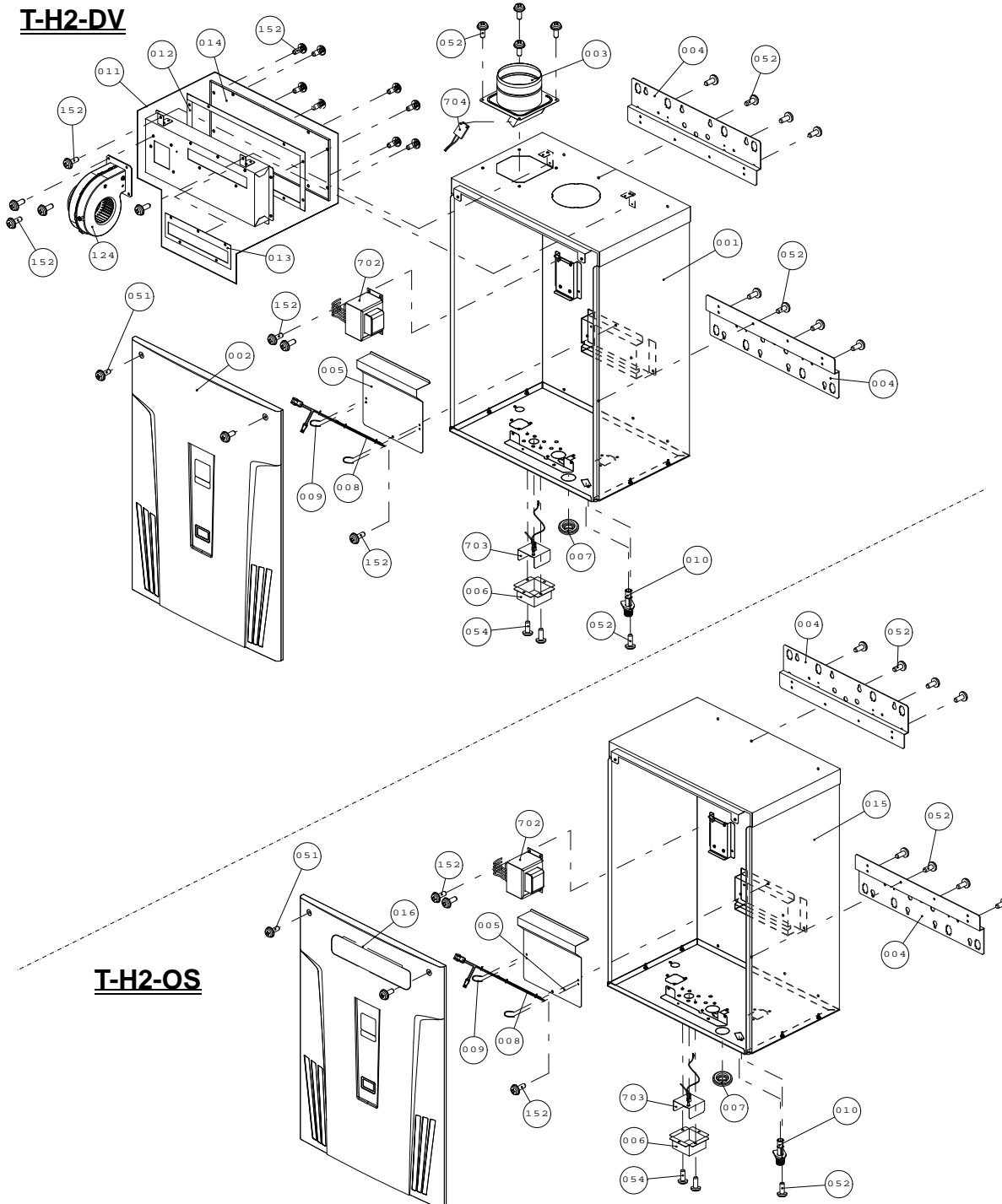

T-H2-OS

Computer board assembly

Other than Part# 719, the T-H2-DV and the T-H2-OS share the same components. The T-H2-OS doesn't have exhaust thermistor assembly (No.716) and exhaust fan motor wire (No.720).

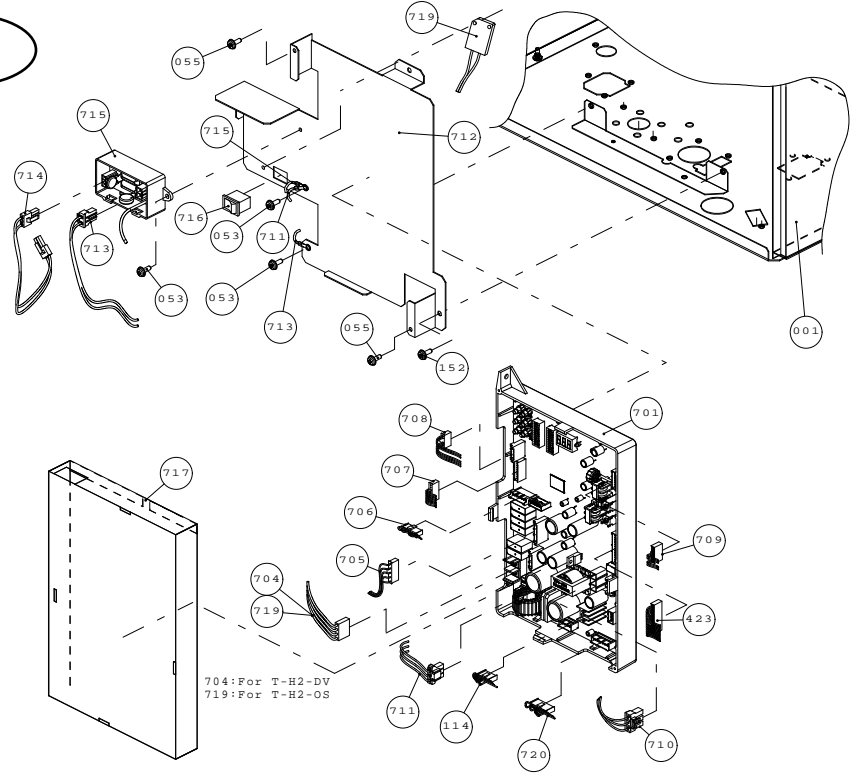

Burner assembly

The T-H2-DV and the T-H2-OS share the same components.

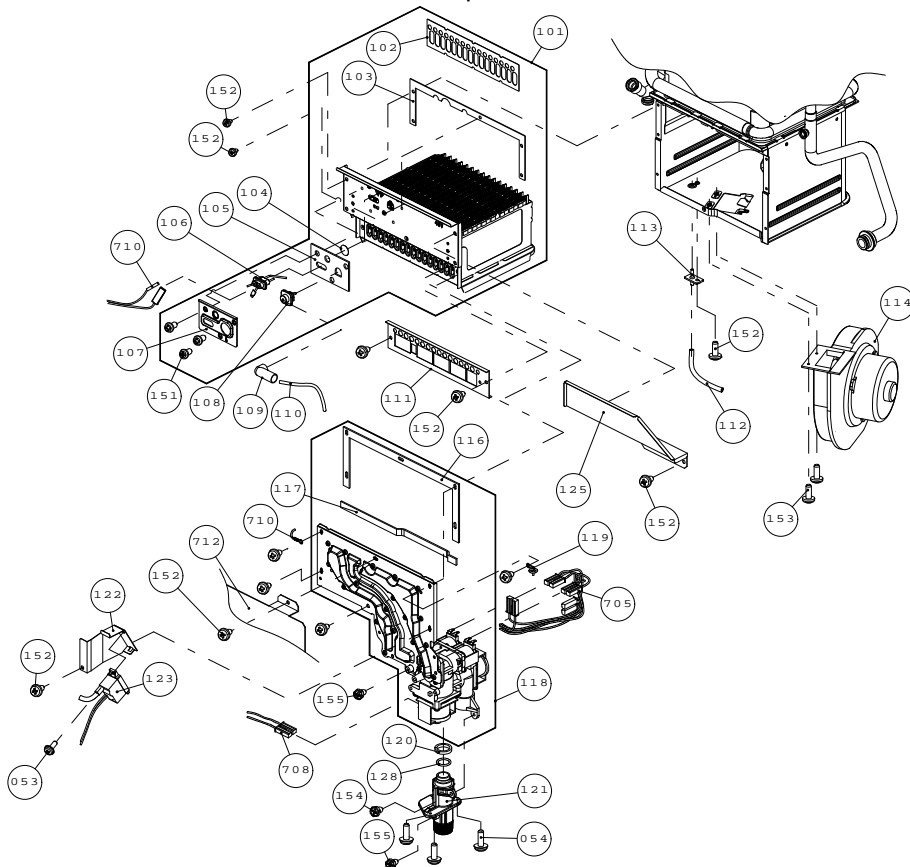

14. Parts list

Item #	Part #	Description	Common parts for other models
001	EKH5B	Case assembly (DV)	
002	EKH5M	Front cover (DV)	
003	EV00K	Intake air port assembly	
004	EM335	Brackets	T-M50
005	EKH5D	Back guard panel	
006	EKJ64	Junction box	T-K3, T-K3-Pro, T-K3-SP/OS, T-KJr2-IN/OS, T-K4-IN/OS, T-D2-IN/OS, T-M50, T-M32
007	EX13M	Rubber bush	
008	EM484	Overheat-cut off-fuse for combustion chamber	T-M32
009	EKK22	Fastener	T-M32
010	EKH23	Condensate drain port	
011	EKH5K	Duct	
012	EKH4G	Duct gasket A	
013	EKH4K	Duct gasket B	
014	EKH73	Duct cover plate	
015	EKH5C	Case assembly (OS)	
016	EKH61	Front cover (OS)	
051	EW000	Screw M4×12 (W/Washer)	*
052	EW002	Screw M4×10 (Coated)	*
053	EX010	Pan screw M4×10	*
054	EW02B	Screw M4×10	*
055	EW023	Pan screw M3×10	*
101	EKH5W	Burner assembly	T-K4-IN/OS, T-D2-IN/OS
102	EKK2X	Burner gasket	T-K3, T-K3-Pro, T-K3-SP/OS, T-KJr2-IN/OS, T-K4-IN/OS, T-D2-IN/OS
103	EKK0G	Burner holder gasket	T-K3, T-K3-Pro, T-K3-SP/OS, T-K4-IN/OS, T-D2-IN/OS, T-M50
104	EKK2V	Burner window	T-K3, T-K3-Pro, T-K3-SP/OS, T-KJr2-IN/OS, T-K4-IN/OS, T-D2-IN/OS, T-M50, T-M32

Item #	Part #	Description	Common parts for other models
105	EKK2W	Rod holder gasket	T-K3, T-K3-Pro, T-K3-SP/OS, T-KJr2-IN/OS, T-K4-IN/OS, T-D2-IN/OS, T-M50, T-M32
106	EKK0E	Flame rod	T-K3, T-K3-Pro, T-K3-SP/OS, T-K4-IN/OS, T-D2-IN/OS, T-M50, T-M32
107	EKK32	Rod holder	T-K3, T-K3-Pro, T-K3-SP/OS, T-K4-IN/OS, T-D2-IN/OS, T-M50, T-M32
108	EKK0F	Igniter rod	T-K3, T-K3-Pro, T-K3-SP/OS, T-K4-IN/OS, T-D2-IN/OS, T-M50, T-M32
109	EKN61	Rod cap	T-K3, T-K3-Pro, T-K3-SP/OS, T-KJr2-IN/OS, T-K4-IN/OS, T-D2-IN/OS, T-M50, T-M32
110	EKK2M	High voltage ignite cable	T-K3, T-K3-Pro, T-K3-SP/OS, T-KJr2-IN/OS, T-K4-IN/OS, T-D2-IN/OS, T-M50
111	EKH5G	Damper	
112	EKK2N	Urethane tube	T-K3, T-K3-Pro, T-K3-SP, T-K4-IN/OS, T-D2-IN/OS
113	EKK2D	Pressure port	T-K3, T-K3-Pro, T-K3-SP, T-K4-IN/OS, T-D2-IN/OS, T-M50, T-M32
114	EKK25	Fan motor	T-K3, T-K3-Pro, T-K3-SP, T-K4-IN, T-D2-IN, T-M50, T-M32
116	EKK2Y	Manifold gasket A	T-K3, T-K3-Pro, T-K3-SP/OS, T-KJr2-IN/OS, T-K4-IN/OS, T-D2-IN/OS, T-M50
117	EKK2K	Manifold gasket B	T-K3, T-K3-Pro, T-K3-SP/OS, T-KJr2-IN/OS, T-K4-IN/OS, T-D2-IN/OS, T-M50
118	EKH6T	Manifold assembly with gas valve assembly LP	T-K4-IN/OS, T-D2-IN/OS
	EKH6U	Manifold assembly with gas valve assembly NA	
119	EM167	Wire clamp 60	T-K3, T-K3-Pro, T-K3-SP/OS, T-KJr2-IN/OS, T-K4-IN/OS, T-D2-IN/OS, T-M50, T-M32
120	EKK2Z	Gas inlet ring	T-K3, T-K3-Pro, T-K3-SP/OS, T-KJr2-IN/OS, T-K4-IN/OS, T-D2-IN/OS
121	EKK1E	Gas inlet	T-K3, T-K3-Pro, T-K3-SP/OS, T-KJr2-IN/OS, T-K4-IN/OS, T-D2-IN/OS

Item #	Part #	Description	Common parts for other models
122	EKK1B	Igniter plate	T-K3, T-K3-Pro, T-K3-SP/OS, T-KJr2-IN/OS, T-K4-IN/OS, T-D2-IN/OS, T-M50, T-M32
123	EKN74	Igniter	T-K3, T-K3-Pro, T-K3-SP/OS, T-KJr2-IN/OS, T-K4-IN/OS, T-D2-IN/OS, T-M50, T-M32
124	EKH5T	Fan motor for exhaust	
125	EX12X	Heat exchanger protection plate (Front)	
126	EX12Y	Heat exchanger protection plate (Right)	
127	EX12Z	Heat exchanger protection plate (Left)	
128	EK042	O-ring P20 NBR	T-K3, T-K3-Pro, T-K3-SP/OS, T-KJr2-IN/OS, T-K4-IN/OS, T-D2-IN/OS, T-M50
150	EW012	Screw M4×8	*
151	EW00D	Pan screw M4×8	*
152	EW003	Screw M4×10	*
153	EW00H	Pan screw M4×12 (W/Washer)	*
154	EW006	Pan screw M4×10	*
155	EW005	Hex head screw M4×8	*
156	EKH4V	Flange gasket for fan motor	
157	EKK3G	Silicon ring	T-K3-OS, T-M50
401	EKH5P	Heat exchanger assembly (DV)	
402	EKN50	Silicon ring	T-K3, T-K3-Pro, T-K3-SP, T-KJr2-IN/OS, T-K4-IN/OS, T-D2-IN/OS, T-M32
403	EKK26	Fuse fixing plate 18	T-K3, T-K3-Pro, T-K3-SP/OS, T-KJr2-IN/OS, T-K4-IN/OS, T-D2-IN/OS, T-M50, T-M32
404	EX02A	Overheat-cut-off fuse	
405	EX002	Heater 101	T-M50, T-M32
406	EKH40	Drain port	

Item #	Part #	Description	Common parts for other models
407	EM222	Filter plug	T-M50, T-M32
408	EZF25	O-ring P25 FKM	
409	EX006	Water inlet filter	T-M50, T-M32
410	EZH21	O-ring JASO# 1021 FKM	
411	EM404	Water inlet	T-M32
412	EZH16	O-ring JASO# 1016 FKM	
413	EX021	Heater plate	T-M50, T-M32
414	EX01H	Fastener "16AG"	T-M50, T-M32
415	EKK2P	Outlet heater	T-K3, T-K3-Pro, T-K3-SP/OS, T-KJr2-IN/OS, T-K4-IN/OS, T-D2-IN/OS, T-M32
416	EK239	Outlet drain plug	T-M32
417	EZF06	O-ring P6 FKM	
418	EX00H	Mixing thermistor	T-M32
419	EZF04	O-ring P4 FKM	
420	EZF16	O-ring P16 FKM	
421	EKH74	Cold pipe	
422	EKK38	Inlet thermistor	T-K3, T-K3-Pro, T-D2-IN/OS, T-M50, T-M32
423	EKH32	Water control valve	T-M50, T-M32
424	EW00A	Screw M3×6	
425	EKK27	Pipe heater fixing plate	T-K3, T-K3-Pro, T-K3-SP/OS, T-KJr2-IN/OS, T-K4-IN/OS, T-D2-IN/OS, T-M50, T-M32
426	EKJ47	Pipe heater 120	
427	EW00L	Pan screw M4×6 (W/Washer)	
428	EZF15	O-ring P15 FKM	
429	EKH33	Flow sensor	T-M50, T-M32
430	EKH75	Hot pipe	
431	EX137	Joint elbow	
432	EKN34	Hi-limit switch	T-K3, T-K3-Pro, T-K3-SP/OS, T-D2-IN/OS, T-M50, T-M32
433	EKK2T	Output thermistor	T-K3, T-K3-Pro, T-D2-IN/OS, T-M50, T-M32
434	EKH30	Fastener "4-11"	T-K3, T-K3-Pro, T-D2-IN/OS, , T-M50, T-M32

Item #	Part #	Description	Common parts for other models
435	EKJ02	Water outlet	T-M32
436	EZH17	O-ring JASO# 1017 FKM	
437	EZF14	O-ring P14 FKM	
438	EKH6H	Drain tube	
440	EKH4H	Secondary heat exchanger plate gasket A	
441	EKH4J	Secondary heat exchanger plate gasket B	
442	EKH6G	Hi-limit switch for exhaust	
443	EKK24	Fastener "14-22"	T-K3, T-K3-Pro, T-K3-SP/OS, T-KJr2-IN/OS, T-K4-IN/OS, T-D2-IN/OS
444	EX13H	Thermistor fixing plate	
445	EKH5N	Secondary heat exchanger plate	
446	EKH6X	Secondary heat exchanger	
447	EKH66	Drain pipe	
448	EKH78	Secondary heat exchanger out pipe	
449	EX13L	Exhaust thermistor gasket	
450	EX12K	Fastener "6-15"	
451	EKH1Y	Band B	
452	EX13B	Header	
453	EX13P	Flat heater	
454	EX13R	3 array heater	
455	EZF12	O-ring P12 FKM	
456	EKH63	Heat exchanger assembly (OS)	
457	EZF03	O-ring P3 FKM	
458	EX13A	Secondary heat exchanger drain plug	
459	EX13J	Exhaust port	

Item #	Part #	Description	Common parts for other models
460	EKH65	Exhaust chamber assembly	
461	EKH62	Secondary heat exchanger plate	
462	EKH38	Heater fixing plate 20	T-M50
463	EK031	Heater fixing plate 16	T-KJr2-IN/OS, T-K4-IN/OS, T-D2-IN/OS, T-M50, T-M32
701	EKH4E	PCB	
702	EM296	Transformer	T-M50
703	EKJ66	Junction box inner plate	T-K3, T-K3-Pro, T-K3-SP/OS, T-KJr2-IN/OS, T-K4-IN/OS, T-D2-IN/OS
704	EKH79	Freeze protection and EH-IG wire (DV)	
705	EKH6V	Gas valve wire	
706	EKH6E	Exhaust thermistor assembly	
707	EKH6J	Thermistors wire	
708	EKK12	Proportional gas valve wire	T-K3, T-K3-Pro, T-D2-IN/OS
709	EKH6F	Pump and multi-cable	
710	EKH69	Flame rod wire	
711	EKH6D	Switch wire	
712	EKH71	PCB fixing plate	
713	EKK3C	AC120V wire	T-K3-SP/OS, T-K4-IN/OS, T-D2-IN/OS
714	EKH6C	AC120V Transformer wire	
715	EKH67	Fuse box	
716	EKK4V	AC120V power ON-OFF switch	T-K3-SP/OS, T-KJr2-IN/OS, T-K4-IN/OS, T-D2-IN/OS
717	EKH68	PCB cover	
718	EC00X	Nylon clamp	T-K3, T-K3-Pro, T-K3-SP/OS, T-KJr2-IN/OS, T-K4-IN/OS, T-D2-IN/OS, T-M32
719	EKH7A	Freeze protection and EH-IG wire (OS)	
720	EKH6A	Exhaust fan motor wire	
721	EKH6B	Exhaust thermistor wire	