

### 13. Components diagrams

Case assembly

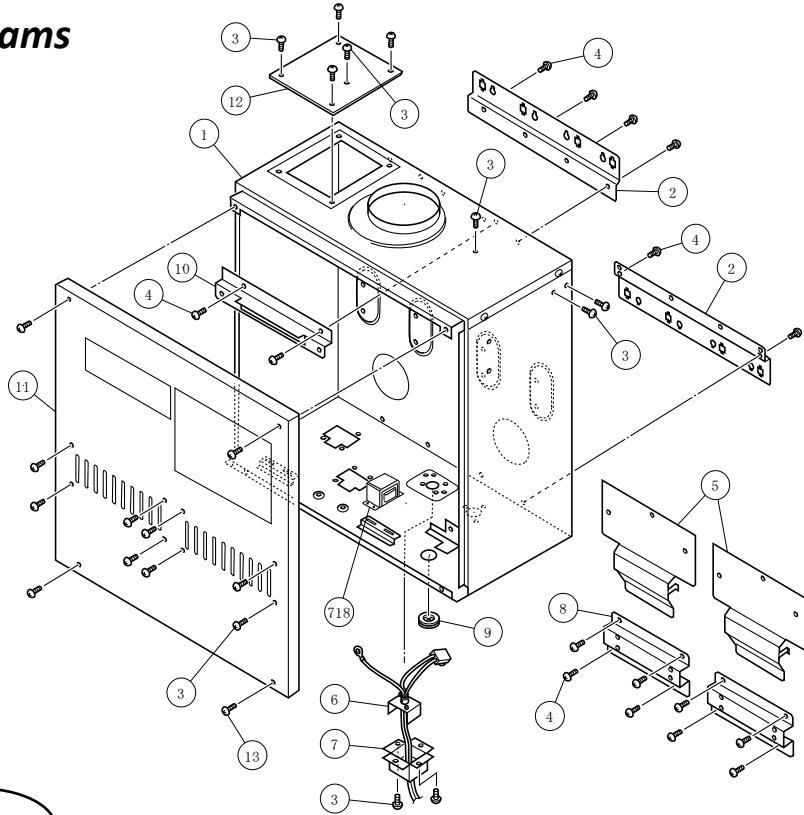

Computer board assembly

The T-M50 and the T-M50 ASME share the same components.

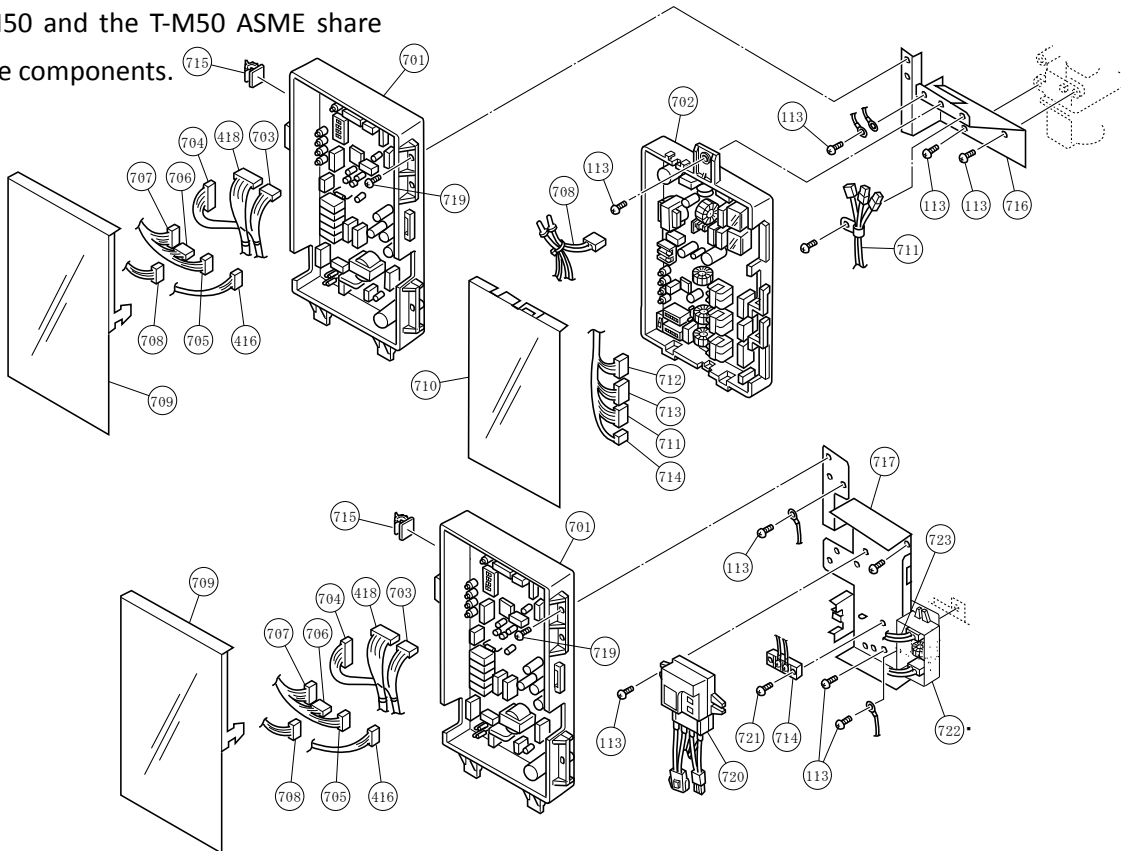

### Burner assembly

The T-M50 and the T-M50 ASME share the same components.

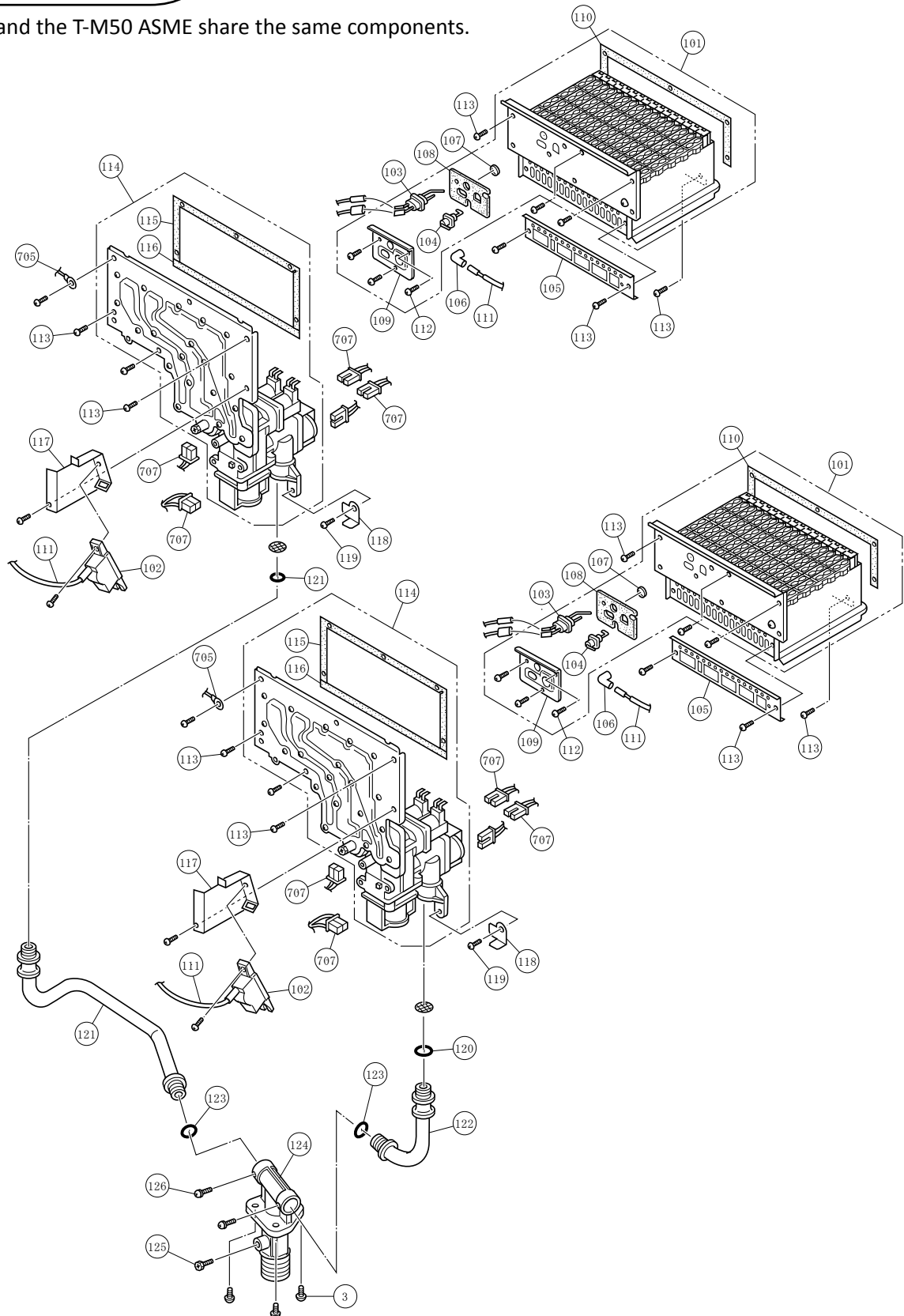

## Combustion and Exhaust assembly

Other than Part# 444, Part# 445, Part# 446 and Part# 447, the T-M50 and the T-M50 ASME share the same components.

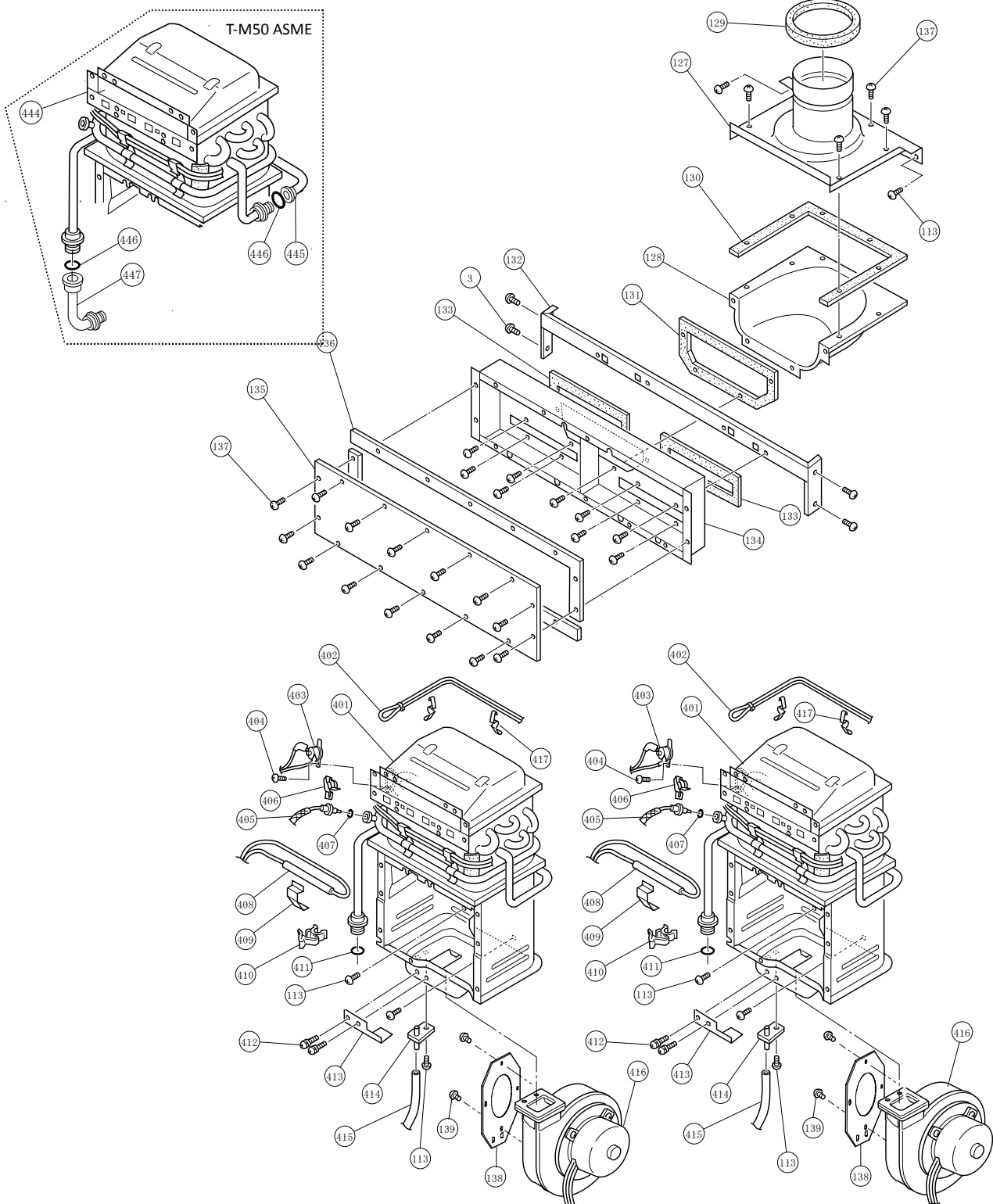

Water way assembly

**T-M50**

**T-M50 ASME**

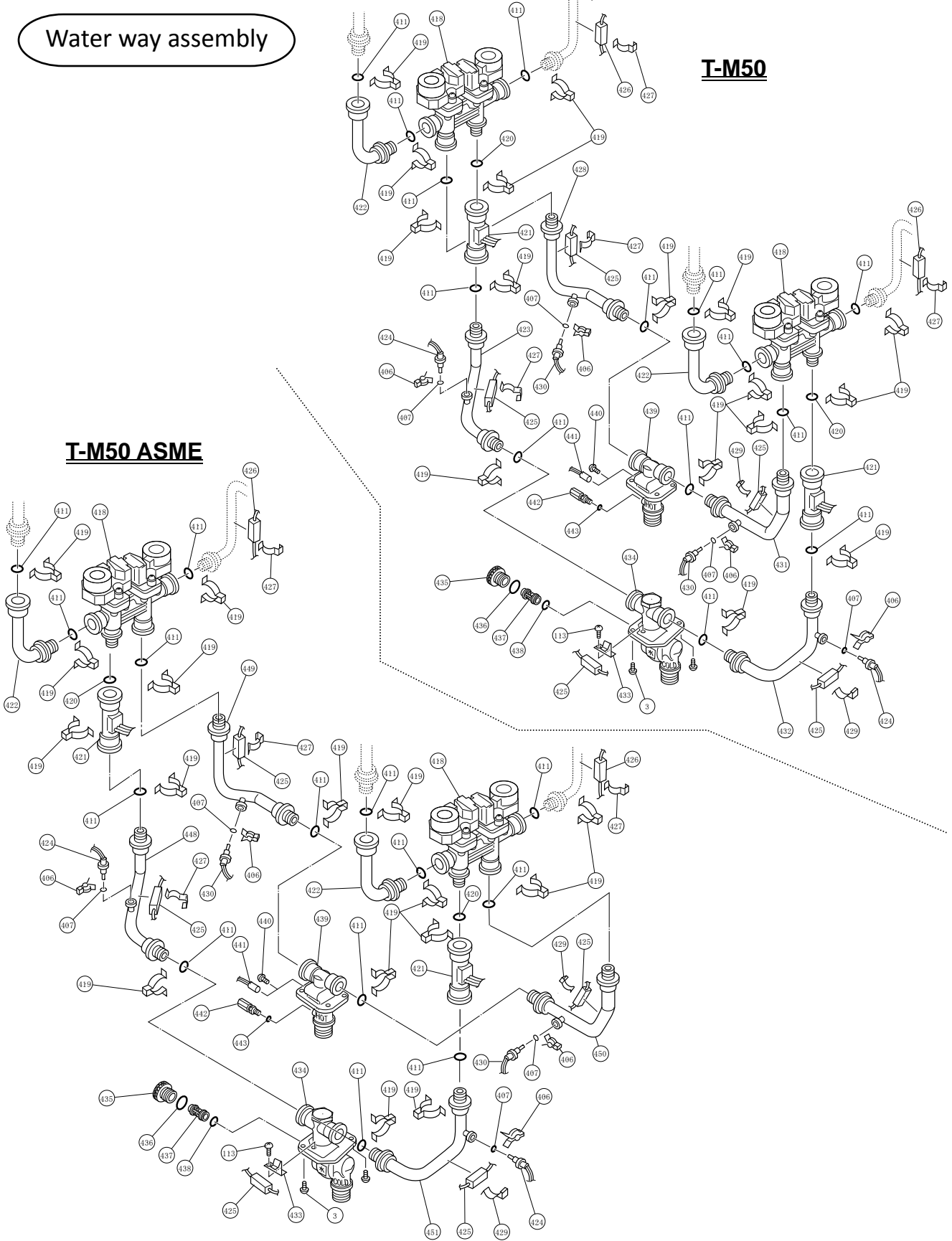

## 14. Parts list

Item #	Part #	Description	Common parts for other models
1	EM305	Case assembly	
2	EM335	Brackets	T-H2-DV/OS
3	EW001	Screw M4X10 (W/Washer)	*
4	EW002	Screw M4X10 (Coated)	*
5	EM264	Back guard panel	
6	EM333	Power supply code assembly	
7	EKJ64	Junction box	T-K3, T-K3-Pro, T-K3-SP/OS, T-H2-DV/OS, T-KJr2-IN/OS, T-K4-IN/OS, T-D2-IN/OS, T-M32
8	EM255	Chamber fixing plate	
9	EX00B	Rubber bush	T-M32
10	EM263	Exhaust fixing plate	
11	EM301	Front cover	
12	EM278	Air blockage plate	
13	EW000	Screw M4X12 (W/Washer)	*
101	EM445	Burner assembly	
102	EKN74	Igniter	T-K3, T-K3-Pro, T-K3-SP/OS, T-H2-DV/OS, T-KJr2-IN/OS, T-K4-IN/OS, T-D2-IN/OS, T-M32
103	EKK0E	Flame rod	T-K3, T-K3-Pro, T-K3-SP/OS, T-H2-DV/OS, T-K4-IN/OS, T-D2-IN/OS, T-M32
104	EKK0F	Igniter rod	T-K3, T-K3-Pro, T-K3-SP/OS, T-H2-DV/OS, T-K4-IN/OS, T-D2-IN/OS, T-M32
105	EKK1P	Damper	T-K3, T-K3-Pro, T-K3-SP
106	EKN61	Rod cap	T-K3, T-K3-Pro, T-K3-SP/OS, T-H2-DV/OS, T-KJr2-IN/OS, T-K4-IN/OS, T-D2-IN/OS, T-M32
107	EKK2V	Burner window	T-K3, T-K3-Pro, T-K3-SP/OS, T-H2-DV/OS, T-KJr2-IN/OS, T-K4-IN/OS, T-D2-IN/OS, T-M32
108	EKK2W	Rod holder gasket	T-K3, T-K3-Pro, T-K3-SP/OS, T-H2-DV/OS, T-KJr2-IN/OS, T-K4-IN/OS, T-D2-IN/OS, T-M32
109	EKK32	Rod holder	T-K3, T-K3-Pro, T-K3-SP/OS, T-H2-DV/OS, T-KJr2-IN/OS, T-K4-IN/OS, T-D2-IN/OS, T-M32

Item #	Part #	Description	Common parts for other models
110	EKK0G	Burner holder gasket	T-K3, T-K3-Pro, T-K3-SP/OS, T-H2-DV/OS, T-K4-IN/OS, T-D2-IN/OS
111	EKK2M	High voltage ignite cable	T-K3, T-K3-Pro, T-K3-SP/OS, T-H2-DV/OS, T-KJr2-IN/OS, T-K4-IN/OS, T-D2-IN/OS
112	EW00D	Pan screw M4X8	
113	EW003	Screw M4X10	*
114	EM302	Manifold assembly with gas valve assembly LP	
	EM303	Manifold assembly with gas valve assembly NA	
115	EKK2Y	Manifold gasket A	T-K3, T-K3-Pro, T-K3-SP/OS, T-H2-DV/OS, T-KJr2-IN/OS, T-K4-IN/OS, T-D2-IN/OS
116	EKK2K	Manifold gasket B	T-K3, T-K3-Pro, T-K3-SP/OS, T-H2-DV/OS, T-KJr2-IN/OS, T-K4-IN/OS, T-D2-IN/OS
117	EKK1B	Igniter plate	T-K3, T-K3-Pro, T-K3-SP/OS, T-H2-DV/OS, T-KJr2-IN/OS, T-K4-IN/OS, T-D2-IN/OS, T-M32
118	EX00J	Gas connection plate	
119	EW006	Pan screw M4X10	*
120	EK042	O-ring P20 NBR (Black)	T-K3, T-K3-Pro, T-K3-SP/OS, T-H2-DV/OS, T-KJr2-IN/OS, T-K4-IN/OS, T-D2-IN/OS
121	EM293	Gas pipe left	
122	EM289	Gas pipe right	
123	EZP18	O-ring P18 NBR (Black)	T-K3, T-K3-Pro, T-K3-SP/OS, T-KJr2-IN/OS, T-K4-IN/OS, T-D2-IN/OS
124	EM284	Gas inlet	
125	EW005	Hex head screw M4X8	
126	EW00L	Pan screw M4X6 (W/Washer)	
127	EM300	Exhaust connecter	
128	EM331	Exhaust combining box	
129	EKK3G	Silicon ring	T-K3-OS, T-H2-DV/OS, T-K4-IN/OS, T-D2-IN/OS
130	EM266	Exhaust gasket A	

Item #	Part #	Description	Common parts for other models
131	EM267	Exhaust gasket B	
132	EM282	Case beam	
133	EM330	Exhaust auxiliary gasket	
134	EM299	Duct	
135	EM294	Duct cover	
136	EM268	Duct gasket	
137	EW003	Screw M4X10	*
138	EK270	Fan damper	T-K3, T-K3-SP
139	EW00B	Screw M3X6	
140	EM286	Freeze protection thermostat	
401	EM308	Heat exchanger assembly	
402	EK333	Overheat-cut-off-fuse	T-K3, T-K3-Pro, T-K3-SP/OS, T-KJr2-IN/OS, T-K4-IN/OS, T-D2-IN/OS
403	EKN34	Hi-limit switch	T-K3, T-K3-Pro, T-K3-SP/OS, T-H2-IN/OS, T-D2-DV/OS, T-M32
404	EW00A	Screw M3X6	*
405	EKK2T	Output thermistor	T-K3, T-K3-Pro, T-H2-DV/OS, T-D2-IN/OS, T-M32
406	EKH30	Fastener "4-11"	T-K3, T-K3-Pro, T-H2-DV/OS, T-D2-IN/OS, T-M32
407	EZM04	O-ring P4 FKM	T-K3, T-K3-Pro, T-K3-SP/OS, T-H2-DV/OS, T-KJr2-IN/OS, T-K4-IN/OS, T-D2-IN/OS, T-M32
408	EKN86	Pipe heater 122	T-K3-Pro, T-M32
409	EKK27	Heater fixing plate	T-K3, T-K3-SP/OS, T-H2-DV/OS, T-KJr2-IN/OS, T-K4-IN/OS, T-D2-IN/OS, T-M32
411	EZM16	O-ring P16 FKM	T-K3, T-K3-Pro, T-K3-SP/OS, T-KJr2-IN/OS, T-K4-IN/OS, T-D2-IN/OS, T-M32
412	EW00H	Pan Screw M4X12 (W/Washer)	*
413	EM252	Fan motor fixing plate	
414	EKK2D	Pressure port	T-K3, T-K3-Pro, T-K3-SP, T-H2-DV/OS, T-K4-IN/OS, T-D2-IN/OS, T-M32
415	EX019	Urethane tube	T-K4-IN/OS, T-D2-IN/OS

Item #	Part #	Description	Common parts for other models
416	EKK25	Fan motor	T-K3, T-K3-Pro, T-K3-SP, T-H2-DV/OS, T-K4-IN/OS, T-D2-IN/OS, T-M32
417	EKK26	Fuse fixing plate 18	T-K3, T-K3-Pro, T-K3-SP/OS, T-H2-DV/OS, T-KJr2-IN/OS, T-K4-IN/OS, T-D2-IN/OS, T-M32
418	EKH32	Water control valve	T-H2-DV/OS, T-M32
419	EX01H	Fastener "16AG"	T-H2-DV/OS, T-M32
420	EZM15	O-ring P15 FKM	T-K3, T-K3-Pro, T-K3-SP/OS, T-KJr2-IN/OS, T-K4-IN/OS, T-D2-IN/OS, T-M32
421	EKH33	Flow sensor	T-H2-DV/OS, T-M32
422	EM285	Connecting pipe	
423	EM290	Left cold pipe for T-M50	
424	EKK38	Inlet thermistor	T-K3, T-K3-Pro, T-H2-DV/OS, T-D2-IN/OS, T-M32
425	EX001	Heater 502	
426	EX002	Heater 101	T-H2-DV/OS, T-M32
427	EK031	Heater fixing plate 16	T-H2-DV/OS, T-KJr2-IN/OS, T-K4-IN/OS, T-D2-IN/OS, T-M32
428	EM328	Left hot pipe for T-M50	
429	EKH38	Heater fixing plate 20	T-H2-DV/OS
430	EKK1A	Mixing thermistor	T-K3, T-K3-Pro, T-D2-IN/OS
431	EM292	Right hot pipe for T-M50	
432	EM291	Right cold pipe for T-M50	
433	EX021	Heater plate	T-H2-DV/OS, T-M32
434	EM295	Water inlet	
435	EM222	Filter plug	T-H2-DV/OS, T-M32
436	EZM25	O-ring P25 FKM	T-M32
437	EX006	Water inlet filter	T-H2-DV/OS, T-M32
438	EZN21	O-ring JASO#1021 FKM	T-M32
439	EM309	Water outlet	
440	EW009	Screw M4X6	



Item #	Part #	Description	Common parts for other models
441	EKN67	Heater 117	
442	EKK2E	Outlet drain plug	T-K3, T-K3-Pro, T-K3-SP/OS, T-Kjr2-IN/OS, T-K4-IN/OS, T-D2-IN/OS
443	EZM06	O-ring P6 FKM	T-K3, T-K3-Pro, T-K3-SP/OS, T-Kjr2-IN/OS, T-K4-IN/OS, T-D2-IN/OS, T-M32
444	EM323	Heat exchanger assembly for T-M50 ASME	
445	EM326	Connection pipe for T-M50 ASME	
446	EZM18	O-ring P18 FKM	T-M32
447	EM370	Connecting pipe for T-M50 ASME	
448	EM456	Left cold pipe for T-M50 ASME	
449	EM459	Left hot pipe for T-M50 ASME	
450	EM458	Right hot pipe for T-M50 ASME	
451	EM457	Right cold pipe for T-M50 ASME	
701	EM306	Left / Right Computer board	
702	EM307	Central computer board	
703	EM258	PV-FS wire	
704	EM260	Thermistor connecting wire	
705	EM271	Flame rod wire	
706	EM257	Igniter wire	
707	EM280	Gas valve wire	
708	EM277	AC 100V wire	
709	EKH43	Left / Right Computer board cover	
710	EM329	Central computer board cover	
711	EM279	Multi communication wire	
712	EM261	Left communication wire	

Item #	Part #	Description	Common parts for other models
713	EM262	Right communication wire	
714	EM273	Remote controller terminal	
715	EM167	Wire cramp 60	T-K3, T-K3-Pro, T-K3-SP/OS, T-H2-DV/OS, T-KJr2-IN/OS, T-K4-IN/OS, T-D2-IN/OS, T-M32
716	EM269	Left PCB fixing plate	
717	EM270	Right PCB fixing plate	
718	EM296	Transformer	T-H2-DV/OS
719	EX013	Screw M4X12	*
720	EM207	Ground fault circuit interrupter	T-M32
721	EW01A	Screw M3 X 12	
722	EM385	Surge box	T-M32
723	EKK4U	Surge connecting wire	