

**PRODUCT PRESERVERS®**  
ANTI-SCALE FILTER SYSTEM



## Installation Instructions

PP-AS20 Anti-Scale System

**THIS UNIT MUST BE INSTALLED BY A  
LICENSED PLUMBER TO VALIDATE THE WARRANTY.**

#### COMPONENTS

- PP-AS20 Filter Housing
- PP-AS20R Filter Cartridge
- Installation Instructions
- (1) Wrench
- (1) Bracket

#### PP-AS20 Specifications

Connection Size	3/4" NPT
Maximum Flow	7 gpm
Minimum Pressure	20 psi
Maximum Pressure	100 psi
Minimum Temperature	40° F
Maximum Temperature	100° F
Maximum Hardness	45 gpg
Maximum Chlorine	2.0 ppm

**Install on cold water lines only**

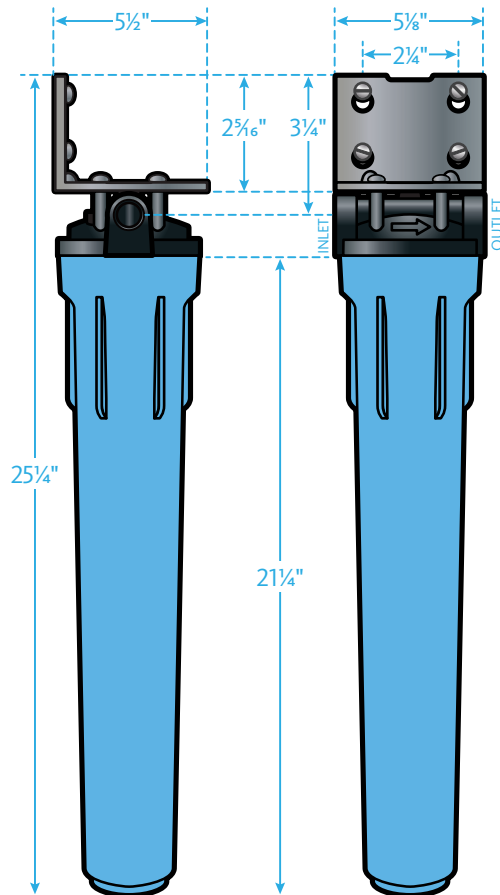

## Precautions

- Read all precautions, installation, and operating instructions carefully and completely before installing unit.
- Do not discard Owner's Manual.
- Install in accordance with all state and local plumbing codes.
- Do not install where line pressure may exceed 100 psi. Operating pressure range is 20-100 psi.
- Install on cold water lines only. Protect unit from freezing. Operating temperature range is 40-100° F.
- Install unit in a vertical, upright, and level position.
- Do not use liquid compounds for connection. Only use plumber's tape for connections.
- Allow a minimum of 3" under the system for cartridge replacements.
- Do not overtighten fittings.

## Installation

1. Consult and follow all applicable state and local plumbing codes.
2. Turn off all equipment to be fed by the PP-AS20.
3. Locate Water supply shutoff valve and turn off.
4. Locate suitable location for installation.
5. Mount unit to wall with included mounting bracket. (Ensure wall material is stable enough for mounting purposes.)
6. Run a suitable line from the incoming cold water line to the inlet (left) side of the left side of the Product Preservers system.  
**NOTE:** Do not over tighten connection fittings. Do not use pipe dope. Do not use more than seven layers of plumber's tape.
7. A bypass line is recommended to be installed. (Not included)
8. Select a suitable size tubing to run from the Product Preservers outlet to the tankless water heater. A drain valve (not included) is recommended to be installed after the filter for flushing and filter cartridge changes.  
**NOTE:** If not installing a drain valve, do not connect the tubing to the tankless water heater at this time. This line will be used to flush the system.
9. Once system is installed slowly apply pressure by slightly opening feed water valve. If drain valve is installed, open valve to purge any air that is in the line.
10. After system has fully pressurized inspect for any leaks.
11. Flush system by opening drain line valve. If no valve was installed, flush BEFORE connecting line to the tankless water heater. Flush for 2 minutes.
12. If there is not a pressure relief valve installed on the tankless water heater hot water outlet, install a brass tee on the tankless outlet. Install a pressure relief valve to one side of the tee. Connect the hot water line to the other side of the tee.
13. Note installation date for replacement element scheduling. Change the filter cartridge at least once every two years.

### Important:

Do not over tighten fittings as this may cause leakage and broken fittings. Do NOT use pipe dope. The use of pipe dope voids the warranty. You may use plumber's tape. Leave two-three threads exposed and do not exceed seven layers of plumber's tape. More than seven layers will cause the nipple to crack and leak.

## Installation

Basic with Bypass Loop and Optional PP-PRE-AS20 Pre-Filter

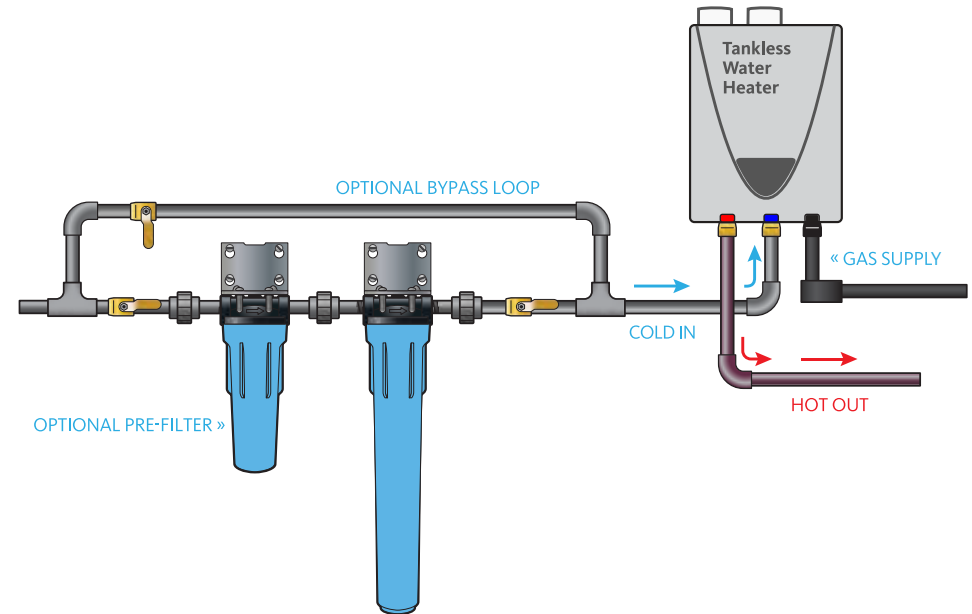

## Installation

Recirculation System

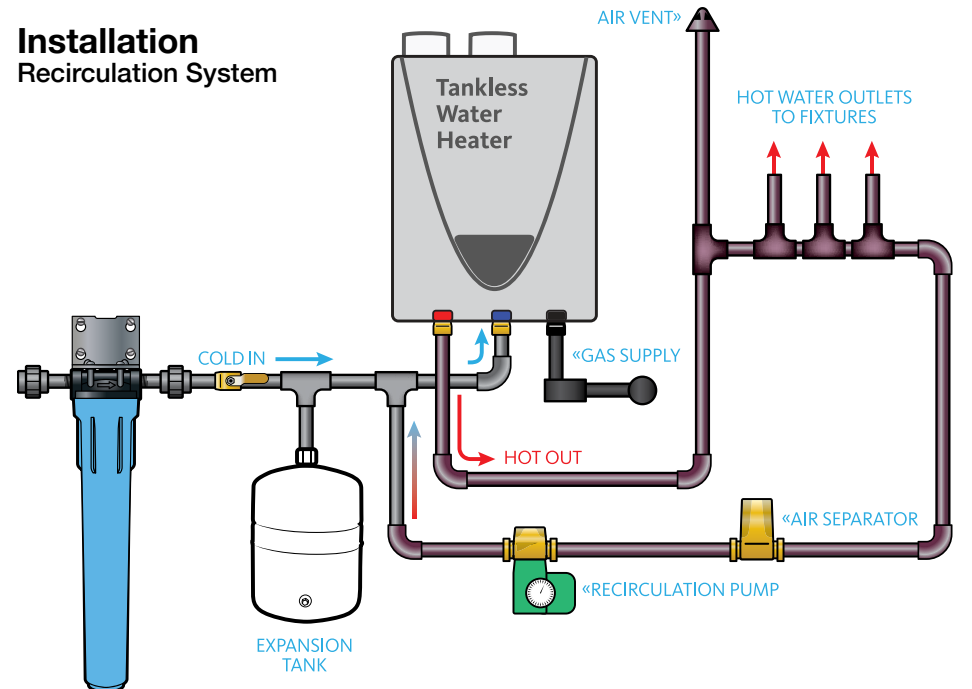

# PP-AS20 Replacement Instructions

- Determine if equipment connected to your Product Preservers System must be turned off before shutting off water.
- If bypass line is installed, bypass system during filter change. Open bypass valve, close unit inlet valve, and close unit outlet valve. *Figure A*
- If no bypass line is installed, turn off feed water.
- Release pressure to system by pressing red button on top of unit. *Figure B*
- Unscrew housing sump using included wrench if necessary. *Figure C*
- Discard old cartridge. Retain spacer. *Figure D*
- Insert new cartridge into sump. Re-use the spacer that was included with the original unit. *Figure D*
- Inspect O-ring for any damage and replace if necessary. *Figure E*
- Re-install filter housing sump. **HAND TIGHTEN ONLY.**
- Pressurize system by slightly opening feed valve. Once pressurized, open valve fully. Inspect seals for any leaks. If there is a leak, you may tighten the sump slightly more with the wrench.
- Flush system for 2 minutes with drain valve open. If no drain valve is installed disconnect from equipment for flush cycle.
- Turn on all equipment connected to system.
- Record filter change date for replacement element scheduling.

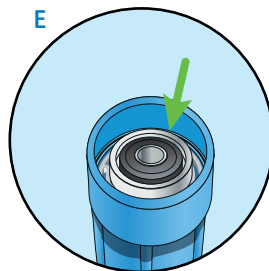
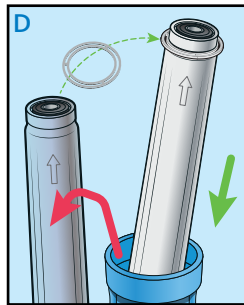
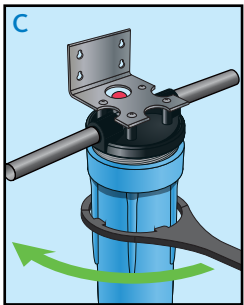
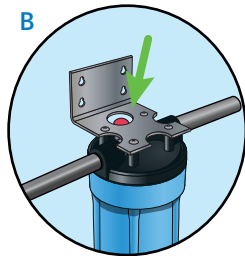
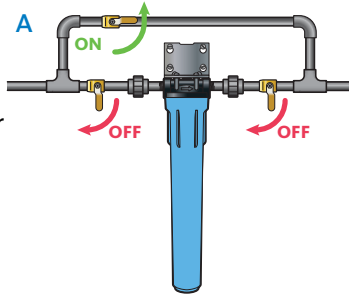

# PP-AS20 Maintenance History

CHANGE THE FILTER CARTRIDGE AT LEAST ONCE EVERY TWO YEARS.

Date	Service Performed	Initial

CUT HERE AND ATTACH TO SYSTEM

## CONDITIONS

- The Product Preservers® system must be installed in applications with municipally supplied water adhering to EPA guidelines.
- Any component failure must not result from abuse, fire, freezing or other acts of nature, violence, or improper installation.
- Equipment must be installed and operated in compliance with the local plumbing codes and on an approved water supply.
- Equipment is limited to use at water pressures and temperatures that do not exceed our published specifications.
- Water supply must not exceed 2.0 PPM chlorine. For water supply exceeding 2.0 PPM chlorine, pretreatment is required. (Please contact your water treatment specialist.)
- Information, including model number, serial number, and date of installation, must be provided for any claims pertaining to equipment in warranty.
- Defective parts are subject to inspection by the company or any authorized representative before final commitment of warranty adjustment is made.
- The company reserves the right to make changes or substitutions in parts or equipment with material of equal quality or value and of then current production.

## LIMITATIONS

Our obligation under this warranty with respect to the tank or valve is limited to furnishing a replacement for, or at our option, repairing any part or parts to our satisfaction that prove defective within the warranty period stated on the back cover. Such replacement parts will be delivered to the owner F.O.B. nearest factory, at no cost, excluding freight and local labor charges, if any.

Our obligation under this warranty with respect to the Product Preservers® media will be limited to furnishing a replacement for the media within two years from date of original installation. Such replacement media will be delivered to the owner F.O.B. nearest factory, at no cost, excluding freight and local labor charges, if any. Damage to the media due to chlorine, other oxidizers or fouling caused by local water conditions or any other operation outside of the limits shown under Specifications, is not covered by this warranty.

THE WARRANTY SET FORTH HEREIN IS GIVEN EXPRESSLY AND IS THE ONLY WARRANTY GIVEN BY A. O. SMITH WATER HEATERS WITH RESPECT TO THE PRODUCT. A. O. SMITH WATER HEATERS MAKES NO OTHER WARRANTIES, EXPRESS OR IMPLIED. A. O. SMITH WATER HEATERS HEREBY SPECIFICALLY DISCLAIMS ALL OTHER WARRANTIES, EXPRESS OR IMPLIED, INCLUDING BUT NOT LIMITED TO THE IMPLIED WARRANTIES OF MERCHANTABILITY AND FITNESS FOR A PARTICULAR PURPOSE.

The remedy described under this warranty shall constitute the sole and exclusive remedy for breach of warranty, and the company shall not be responsible for any incidental, special or consequential damages, including without limitation, freight, handling, lost profits or the cost of repairing or replacing other property which is damaged if this product does not work properly, other costs resulting from labor charges, delays, vandalism, negligence, fouling caused by foreign material, damage from adverse water conditions, chemical, or any other circumstances over which the company has no control. This warranty shall be invalidated by any abuse, misuse, misapplication or improper installation of the product.

Some states do not allow limitations on how long an implied warranty lasts, and some states do not allow the exclusion or limitation of incidental or consequential damages. Therefore the above limitations may not apply to you. This warranty gives you specific legal rights, and you may have other rights that vary from state to state. You should consult applicable state laws to determine your rights. SO FAR AS IS CONSISTENT WITH APPLICABLE STATE LAW, ANY IMPLIED WARRANTIES THAT MAY NOT BE DISCLAIMED, INCLUDING THE IMPLIED WARRANTIES OF MERCHANTABILITY AND FITNESS FOR A PARTICULAR PURPOSE, ARE LIMITED IN DURATION TO THE APPLICABLE WARRANTY PERIODS STATED ON BACK COVER.

Product Preservers® Anti-Scale System  
500 Tennessee Waltz Parkway  
Ashland City, TN 37015

### **Limited Warranty**

Company warrants its Product Preservers® Anti-Scale System as follows:

- The Product Preservers® cartridge system is warranted to be free of defects in materials and workmanship for two years from the date of original shipment.
- Product Preservers® filter cartridges are warranted for performance for a period of two years from the date of original installation when installed and operated in accordance with the instructions in the corresponding Installation and Operation Manual.

**This product is not intended for use with water that is microbiologically unsafe or of unknown quality without adequate disinfection before or after the unit.**