

E. Components diagram / Parts list

Case assembly

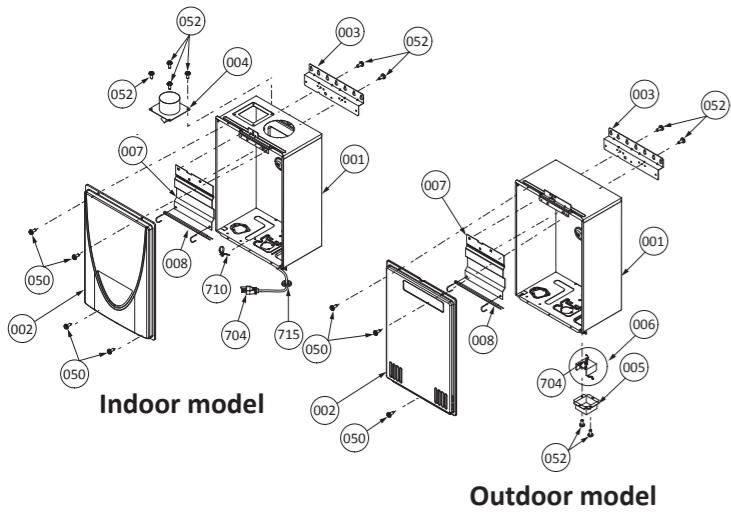

Indoor model

Outdoor model

Surge box

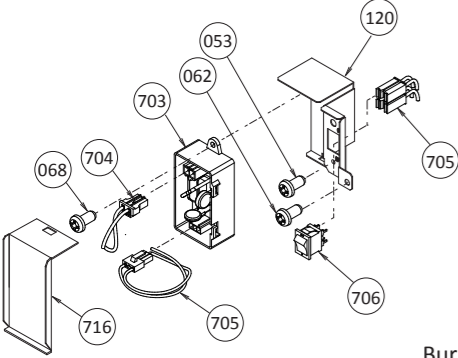

Burner assembly

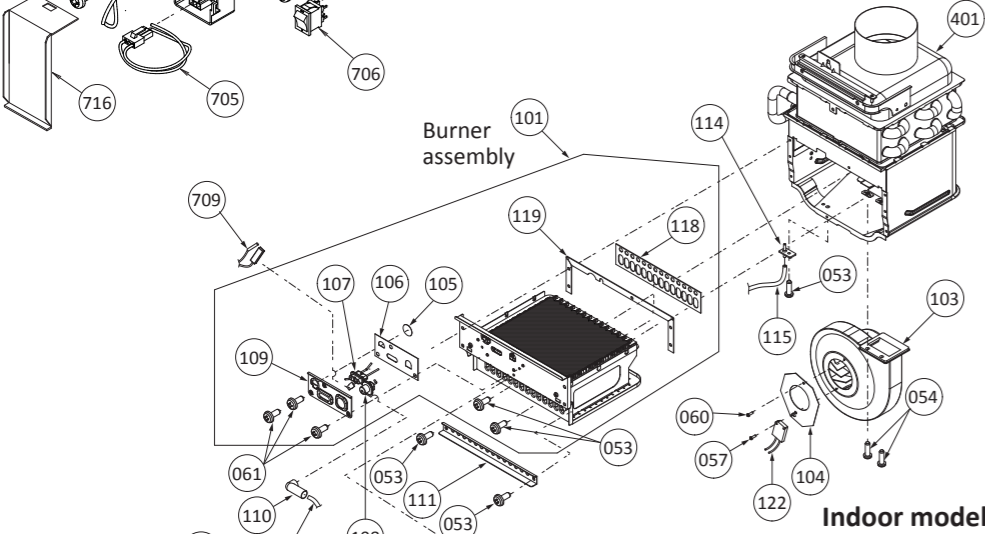

Indoor model

Outdoor model

Built-in temperature controller (Indoor only)

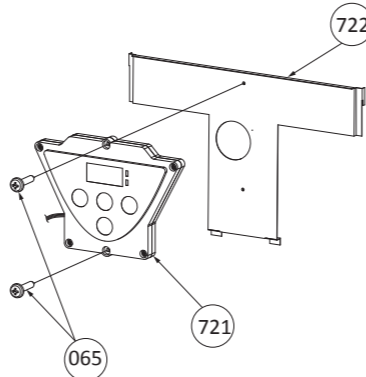

Water way assembly

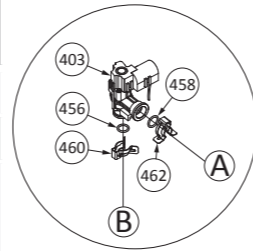

Bypass valve

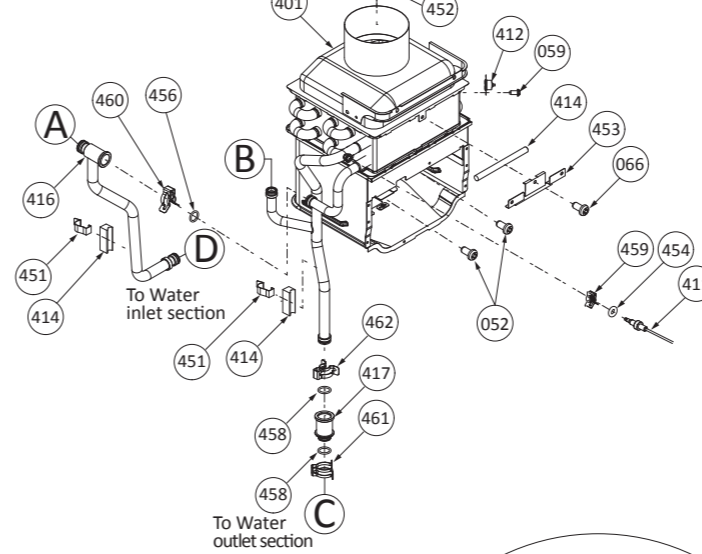

Water outlet section

Water inlet section

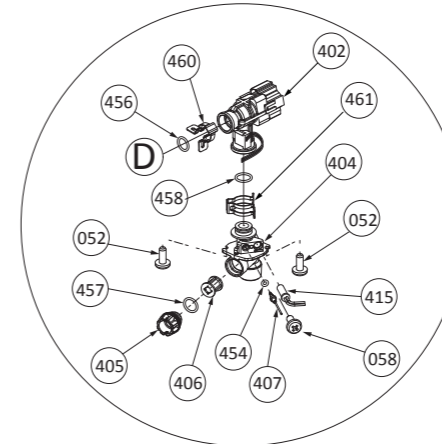
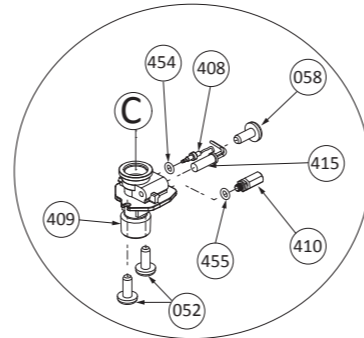

Item #	Part #		Description
	510 U	AT-D3U-IN/OS	
101	100224092	EK554	Burner assembly
102	100224093	EK555	Manifold with gas valve assembly NA
103	100074606	EK109	Fan motor for Indoor model
	100074228	EKK25	Fan motor for Outdoor model
104	100074466	EM381	Fan motor plate for Indoor model
	N/A	EK140	Fan motor plate for Outdoor model
105	100076535	EKN58	Burner window
106	100224097	EK559	Rod holder gasket
107	100224098	EK560	Flame rod with AFR function
108	100224099	EK561	Igniter rod
109	100224100	EK562	Rod holder
110	100076319	EK462	Rod cap
111	100270556	EK602	Burner damper
112	100224102	EK564	Manifold gasket A
113	100224103	EK565	Manifold gasket B
114	100074227	EKK2D	Pressure port
115	100074528	EX019	Combustion chamber tube
116	100074235	EKK1E	Gas inlet
117	100074234	EKK2Z	Gas inlet ring
118	100224105	EK567	Burner gasket
119	100224106	EK568	Burner holder gasket

Item #	Part #		Description
	510 U	AT-D3U-IN/OS	
120	100074360	EK436	Surge box plate
121	N/A	EK603	PCB fixing plate
122	100074369	EKJ59	Thermostat
130	100270585	EK604	LP Conversion kit
131	100281157	EK592	Manifold gasket
150	N/A	EK570	O-ring P18 NBR (Manifold)
151	100074242	EK042	O-ring P20 NBR (Black)
152	100074390	EKK3G	Silicon ring for Outdoor model
153	100074400	EKK53	Rain protection plate in Exhaust chamber for Outdoor model
154	100074403	EKK56	Exhaust port for Outdoor model
401	100270559	EK607	Heat exchanger assembly for Indoor
	100270560	EK608	Heat exchanger assembly for Outdoor
402	100074624	EK129	Flow adjustment valve / Flow sensor
403	100074625	EKD58	Bypass valve
404	100074377	EKK1U	Water inlet
405	100074381	EKK2B	Inlet drain plug
406	100074382	EKK2C	Inlet water filter
407	100224109	EK573	Inlet thermistor
408	100224110	EK574	Outlet thermistor
409	100074627	EK104	Water outlet
410	100074264	EK239	Outlet drain plug
411	100224111	EK575	Heat exchanger thermistor
412	100074280	EKN34	Hi-Limit switch
413	100074252	EX02A	Overheat-cut-off fuse for heat exchanger
414	100074682	EK209	Pipe heater
415	100074629	EK105	Inlet heater
416	100270581	EK609	Pipe inlet
417	100224113	EK577	Joint outlet
450	N/A	EK616	Fuse fixing plate 40
451	100074310	EK031	Heater fixing plate 16
452	N/A	EK476	Fuse fixing plate 18
453	N/A	EK610	Pipe heater fixing plate
454	100076303	EZM04	O-ring P4 FKM
455	100076305	EZM06	O-ring P6 FKM
456	100076306	EZM14	O-ring P14 FKM
457	100076307	EZM15	O-ring P15 FKM
458	100076308	EZM16	O-ring P16 FKM
459	100074282	EKH30	Fastener "4-11"
460	100074290	EKK24	Fastener "14-22"
461	100074410	EM192	Fastener "16A"
462	100074389	EKK39	Fastener "16-25A"
463	100074250	EKN50	Silicon ring for Indoor model
701	100270584	EK613	Computer board for 510U
702	100074644	EK152	Remote fixing plate
703	100076100	EK280	Surge box
704	100074601	EK146	120 VAC wire for Indoor model
	100074323	EKK3C	120 VAC wire for Outdoor model
705	N/A	EK614	Switch wire
706	N/A	EK590	120 VAC Power ON-OFF switch
707	100074650	EK165	Remote controller wire
708	N/A	EK585	Gas valve wire
709	N/A	EK586	Flame rod wire
710	N/A	EW022	Cable strap
711	100074640	EK153	Igniter assembly
712	100074458	EM329	Computer board cover
713	N/A	EK587	24V cables
714	100074642	EK112	Proportional gas valve wire
715	100074655	EK184	Rubber grommet for Indoor model
716	N/A	EK615	Surge box cover
721	100074660	EK173	Temperature controller
722	N/A	EK588	Controller fixing plate
N/A	100076516	EKK0J	Communication cable for linking*

*Refer to p.9 on the Installation manual.

LP Conversion Kit

