



# T-K3 / T-K3-Pro

## On-Demand Water Heater Installation Manual and Owner's Guide



T-K3-Pro model ONLY

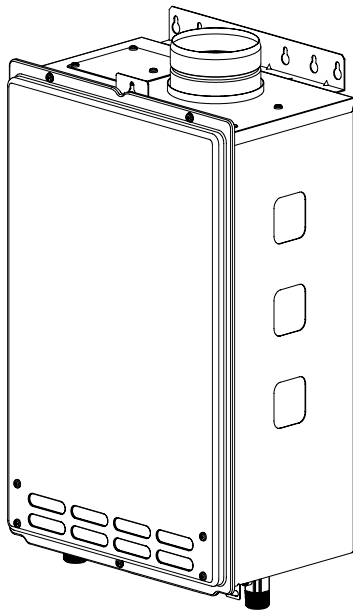

**Flash Water Heater™**

### Model T-K3 and T-K3-Pro

*Suitable for potable water heating and space heating*

#### FEATURING

- ENDLESS HOT WATER
- ON DEMAND USAGE
- COMPACT, SPACE SAVING
- ENERGY CONSERVATION
- COMPUTERIZED SAFETY
- NO PILOT LIGHT
- EASY LINK SYSTEM

### WARNING

This product must be installed and serviced by a licensed plumber, a licensed gas fitter, or a professional service technician. Improper installation and/or operation, or installation by an unqualified person, will void the warranty.

### WARNING

If the information in this manual is not followed exactly, a fire or explosion may result, causing property damage, personal injury, or death.

#### TAKAGI Industrial Co. USA, Inc.

5 Whatney

Irvine, CA 92618

Toll Free: (888) 882-5244 USA

Toll Free: (877) 877-4953 CANADA

## CONTENTS

SPECIFICATIONS.....	2
INTRODUCTION.....	3
SAFETY GUIDELINES.....	4
INSTALLATION.....	5
General.....	6
Included Accessories.....	6
Outdoor Installation.....	8
Indoor Installation.....	9
Direct Intake Vent System.....	10
Venting Instructions.....	11
Gas Supply / Gas Pipe Sizing.....	17
Water Connections.....	19
Pressure Relief Valve.....	20
Electrical Connections.....	21
Remote Controller Connection.....	22
Easy Link System.....	23
Pump Connection.....	26
Initial Operation.....	27
NORMAL OPERATION.....	28
Normal Operation.....	28
Flow.....	29
Freeze Protection System .....	29
Temperature Settings .....	30
Maintenance and Service.....	31
GENERAL TROUBLESHOOTING.....	32
WIRING DIAGRAM.....	35
OPERATING SAFETY.....	36
APPLICATIONS.....	38
Space Heating.....	38
Re-Circulation.....	38
Dual-Purpose Heating.....	39
OPTIONAL ITEMS.....	40
COMPONENTS DIAGRAM.....	41
PARTS LIST.....	44
OUTPUT TEMPERATURE CHART....	46
PRODUCT REGISTRATION AND LIMITED WARRANTY.....	47

## SPECIFICATIONS T-K3 and T-K3-Pro

Natural Gas Input (Operating Range)		Min: 11,000 Btu/h Max: 199,000 Btu/h	
LPG Input (Operating Range)		Min: 11,000 Btu/h Max: 199,000 Btu/h	
Gas Connection		¾" NTP	
Water Connections		¾" NTP	
Water Pressure		15 - 150 psi*	
Natural Gas Pressure Inlet		Min. 5.0" WC Max. 10.5" WC	
LP Gas Pressure Inlet		Min. 8.0" WC Max. 14.0" WC	
Manifold Pressure		Natural: 2.5" WC Propane: 4.4" WC	
Weight		40 lbs.	
Dimensions		H20.5" x W13.8" x D8.5"	
Ignition		Electric Ignition	
Electric	Supply	120VAC (60Hz)	
	Consumption	Operation	92 W (0.77A)
		Standby	6.2 W (0.05A)
	Freeze- Protection	111 W (0.93A)	

\*40 psi or above is recommended for maximum flow

### NOTE

\*Check the rating plate to ensure this product matches your specifications.

\*In accordance with ANSI Z21.10.3 and SCAQMD Rule 1146.2, CO emission does not exceed 400 PPM for normal input

**Takagi reserves the right to discontinue, or change at any time, specifications or designs without notice and without incurring obligations.**

# INTRODUCTION

- This manual provides information necessary for the installation, operation, and maintenance of the Flash T-K3/T-K3-Pro water heater.
- The model description is listed on the rating plate which is attached to the front cover of the water heater.
- Please read all installation instructions completely before installing this product.
- If you have any problems or questions regarding this equipment, consult with Takagi or its local representative.
- The T-K3/T-K3-Pro Water Heater is an on-demand, tankless water heater designed to efficiently supply endless hot water for your needs.
- The principle behind the T-K3/T-K3-Pro Water Heater is simple:

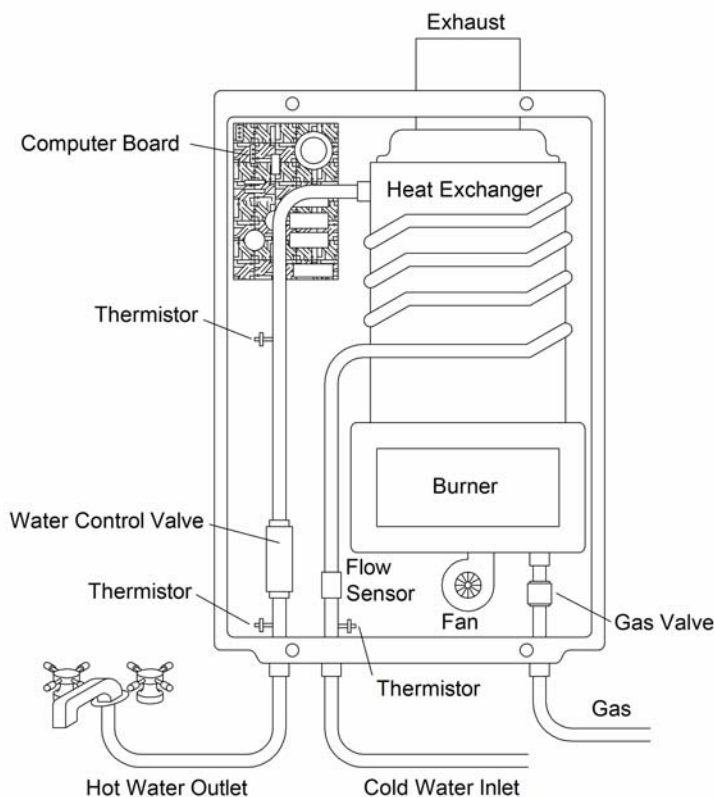

\*This diagram illustrates Takagi's tankless water heater design concepts only and is not accurate to the T-K3/T-K3-Pro's physical description.

1. A hot water tap is turned on.
2. Water enters the heater.
3. The water flow sensor detects the water flow.
4. The computer automatically ignites the burner.
5. Water circulates through the heat exchanger and then gets hot.
6. The computer will modulate the gas supply valve and water flow to produce the right amount of hot water at the correct temperature.
7. When the tap is turned off, the unit shuts down.

# SAFETY GUIDELINES



- Installation and service must be performed by a qualified installer (for example, a licensed plumber or gas fitter), otherwise the warranty by Takagi will be void.
- The installer (licensed professional) is responsible for the correct installation of your Flash T-K3/T-K3-Pro Water Heater and for compliance with all national, state/provincial, and local codes.

PLEASE READ THIS MANUAL CAREFULLY AND FOLLOW ALL DIRECTIONS.

## GENERAL

1. Follow all local codes, or in the absence of local codes, follow the most recent edition of the National Fuel Gas Code: ANSI Z223.1/NFPA 54 in the USA or CAN/CSA B149.1 Natural Gas, Propane Installation Code in Canada.
2. Properly ground the unit in accordance with all local codes or in the absence of local codes, with the National Electrical Codes: ANSI/NFPA 70 in the USA or CSA standard C22.1 Canada Electrical Code Part 1 in Canada.
3. Carefully plan where you intend to install your T-K3/T-K3-Pro Water Heater. Please ensure:
  - Your water heater will have enough combustible air and proper ventilation.
  - Locate your heater where water leakage will not damage surrounding areas (please refer to p. 5).
4. Check the rating plate for the correct **GAS TYPE, GAS PRESSURE, WATER PRESSURE and ELECTRIC RATING.**  
\*If this unit does not match your requirements, **do not install and consult with Takagi.**
5. If any problem should occur, turn off all hot water taps and turn off the gas. Then call a trained technician or the Gas Company or the manufacturer.

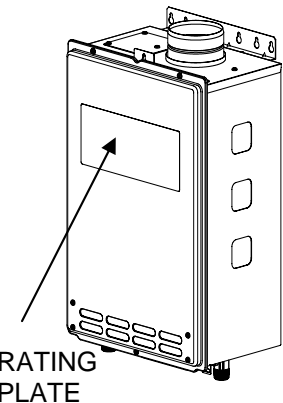

## WARNING

- Water temperatures over 125°F can cause severe burns instantly or death from scalding. The water temperature is set at 122°F (50°C) from the factory to minimize any scalding risk. Before bathing or showering always check the water temperature.



**Prohibited**

- Do not store or use gasoline or other flammables, vapors, or liquids in the vicinity of this appliance.
- Do not reverse the water and/or gas connections as this will damage the gas valves and can cause severe injury or death. Follow the diagram on p. 19 when installing your water heater:
- Do not use this appliance if any part has been in contact with or been immersed in water. Immediately call a licensed plumber, a licensed gas fitter, or a professional service technician to inspect and/or service the unit if necessary.
- Do not disconnect the electrical supply if the ambient temperature will drop below freezing. The Freeze Prevention System only works if the unit has electrical power. The warranty will not be covered if the heat exchanger is damaged due to freezing. Refer to the section on the Freeze Prevention System on p. 29 for more information.



# INSTALLATION

All gas water heaters require careful and correct installation to ensure safe and efficient operation. This manual must be followed exactly. Read the "Safety Guidelines" section at the beginning of this manual.



## CAUTION

- **The warranty will not cover damage caused by water quality.** Water hardness that leads to scale formation and/or corrosion may affect/damage the water heater. Hard water scaling and/or corrosion must be avoided or controlled by proper water treatment.
- **TAKAGI recommends using the Takagi direct vent kit, when the water heater is installed in a beauty salon.** Some chemicals used in a beauty salon may affect the flame sensor. Water heater may not work properly.
- Although the T-K3/T-K3-Pro is designed to operate with minimal sound, **TAKAGI does not recommend installing the unit on a wall adjacent to a bedroom, or a room that is intended for quiet study or meditation, etc.**
- Locate your heater close to a drain where water leakage will not do damage to surrounding areas. As with any water heating appliance, the potential for leakage at some time in the life of the product does exist. Takagi will not be responsible for any water damage that may occur. If you install a drain pan under the unit, ensure that it will not restrict the combustion air flow.



## WARNING



- **TAKAGI does not recommend installing unit in an attic due to safety issues.** If you install your T-K3/T-K3-Pro in an attic:
  - Make sure your unit will have enough combustion air and proper ventilation.
  - Keep the area around your T-K3/T-K3-Pro clean. When dust collects on the flame sensor, the water heater will shut down on errors.
  - If the above conditions cannot be met, use the direct vent conversion kit TK-TV10.
  - Locate unit for easy access for service and maintenance.
  - A drain pan is required to be installed under the water heater in case of leaks.

## GENERAL

1. The manifold gas pressure is preset at the factory. It is computer controlled and should not need adjustment.
2. Maintain proper space for servicing. Install the unit so that it can be connected or removed easily. Refer to p. 7, p.8 and p. 9 for proper clearances.
3. The electrical connection requires a means of disconnection, to terminate power to the water heater for servicing and safety purposes.
4. If you will be installing the unit in a contaminated area with a high level of dust, sand, flour, aerosols or other contaminants/chemicals, they can become airborne and enter and build up within the fan and burner causing damage to the unit. In those environments (e.g. residential or commercial laundry facilities, hair salons, pet salons, chemical plants etc.), please purchase the optional TK-TV10 direct vent conversion kit and convert the T-K3/T-K3-Pro to a sealed combustion unit. Direct venting allows the T-K3/T-K3-Pro to draw fresh intake air from the outside. The warranty will not cover damage caused to the unit due to installation in a contaminated environment that has not been converted using the TK-TV10.
5. Particles from flour, aerosols, and other contaminants may clog the air vent or reduce the functions of the rotating fan and cause improper burning of the gas. Regularly ensure that the area around the unit is dust- or debris-free; regular maintenance is recommended for these types of environment.
6. Do not install the unit where the exhaust vent is pointing into any opening in a building or where the noise may disturb your neighbors. Make sure the vent termination meets the required distance by local code from any doorway or opening to prevent exhaust from entering a building (refer to p. 14).

## INCLUDED ACCESSORIES

Check that the installation manual, the communication cable, and the warranty card are included with the unit.

<b>Items</b>	
Manual	<div style="display: flex; align-items: center; justify-content: center;">  <span>Qty: 1</span> </div>
Communication Cable	<div style="display: flex; align-items: center; justify-content: center;">  <span>Gray Qty: 1</span> </div>
Warranty Card	<div style="display: flex; align-items: center; justify-content: center;">  <span>Qty: 1</span> </div>

## WARNING FOR INSTALLATION LOCATIONS

Do not install the heater where water, debris or flammable vapors may get into the flue terminal. This may cause damage to the heater and void the warranty.



**Prohibited**



Do not have the vent terminal pointing toward any opening into a building. Do not locate your heater in a pit or location where gas and water can accumulate.



**Prohibited**



Do not install this water heater under an overhang less than 3 feet from its top or eaves. The area under an overhang must be open to three sides.

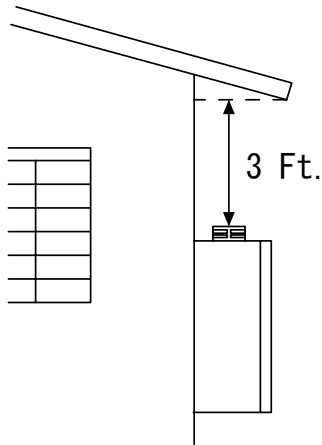

Do not install the water heater vent terminator within 1 ft. in the USA of any air intake or building opening, and within 3 ft. in Canada of any air intake or building opening. (Refer to p.14)

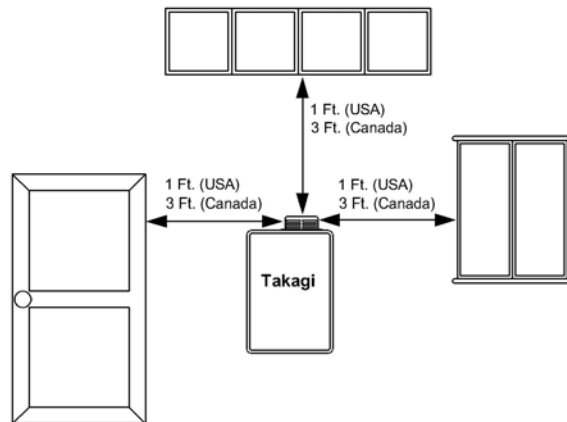

Do not install next to a dryer or any source of airborne debris that can be trapped inside the combustion chamber, unless the system is direct vented.

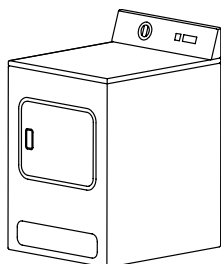

# OUTDOOR INSTALLATION

1. Follow all local codes, or in the absence of local codes, follow the most recent edition of the National Fuel Gas Code: ANSI Z223.1/NFPA 54 in the USA or CAN/CSA B149.1 Natural Gas, Propane Installation Code in Canada.
2. **Install outdoors only in areas with mild, temperate climates.**
3. Ensure that the unit is set for outdoor installation. Locate the bank of dipswitches **to the right** of the 7-Seg. LED on the computer board. The 'OUT' dipswitch on the computer board should be switched to its 'ON' (up) position (Do not adjust the bank of dipswitches above the LED's).



**Make sure power to the unit is turned OFF before changing the dipswitch settings.**

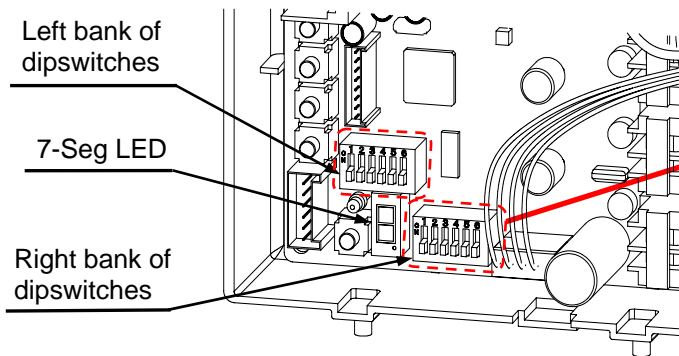

The dark square is the direction the dipswitch should be set to.

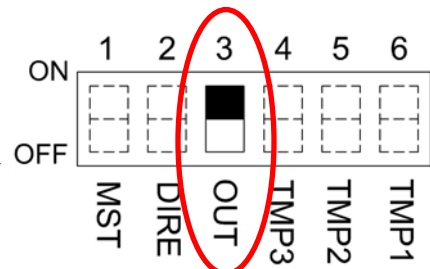

**Right Bank of Dipswitches**

4. The outdoor vent cap must be used when unit is installed outdoor. Takagi requires the use of its part No. TK-TV04.
5. When installed outdoors, the T-K3/T-K3-Pro water heater shall be wall-mounted or mounted on a stand. Locate the water heater in an open, unroofed area and maintain the following minimum clearances:



There is a 2" clearance from the left and right sides of the unit to combustible and non-combustible surfaces. However, if any portion or area of the surface is exposed to the exhaust fumes (i.e. directly to the sides of the vent cap), that surface must be at least 24" away.



Keep the clearances.

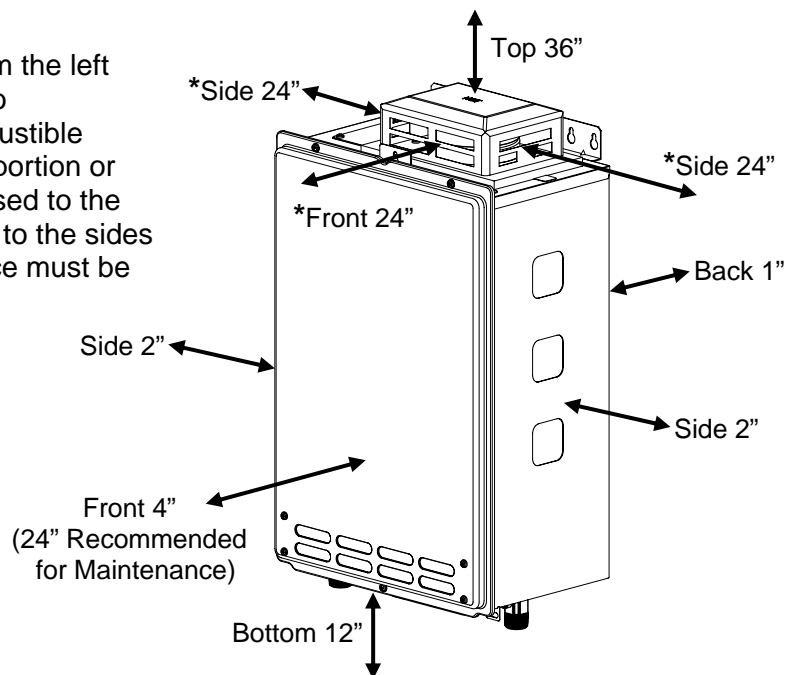



## INDOOR INSTALLATION

1. Follow all local codes, or in the absence of local codes, follow the most recent edition of the National Fuel Gas Code: ANSI Z223.1/NFPA 54 in the USA or CAN/CSA B149.1 Natural Gas, Propane Installation Code in Canada.
2. When installed indoors, the T-K3/T-K3-Pro water heater shall be located in an area to maintain the following minimum clearances around the unit:



Keep the clearances.

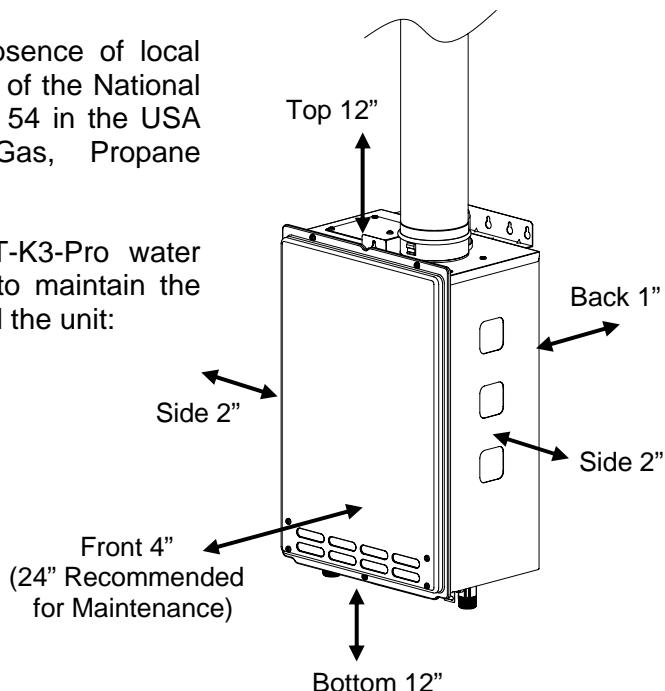

### Combustion Air Supply

The water heater location must provide enough air for proper combustion and ventilation of the surrounding area. See the latest edition of ANSI Standard Z223.1 or any applicable local codes. In general, these requirements specify that if the unit is installed in a confined space, there must be a permanent air supply opening.

#### Minimum recommended air supply opening size for water heater:

Water heater size	When drawing make-up air from outside the building	When drawing make-up air from inside the building (from other rooms within)
MAX 199,000 BTU	<b>13.3 Sq. IN</b>	<b>199 Sq. IN</b>
	When combustion air is supplied from outside the building, an opening communicating directly with the outside should have a minimum free area of one square inch per 15,000 BTUH input of the total input rating of water heater in the enclosed area.	When combustion air is supplied from inside the building, an opening communicating with the rest of the dwelling should have a minimum free area of one square inch per 1,000 BTUH input of the total input rating of water heater in the enclosed area. This opening should never be less than 199 sq. in.

### Combustible Air Supplied by Mechanical fan or Make up air device

The T-K3/T-K3-Pro water heater is equipped with a combustible air sensor that will shut off the unit when inadequate combustible air supply to unit is detected.

- If a mechanical fan or make up air device is used to supply air to the water heater or utility room, the installer should make sure it does not create drafts which could cause nuisance shutdowns.
- If a blower is necessary to provide adequate combustion air to the water heater, the blower and water heater must be set up so that the water heater cannot fire unless the blower is operating. Possible methods include the use of external flow sensors/transmitters and relays.

# DIRECT INTAKE VENT SYSTEM

This T-K3/T-K3-Pro water heater may be converted to a direct vent (sealed combustion) appliance by installing an adapter (Part No. TK-TV10) which will bring all required combustible air from outside the building. When installing the TK-TV10 conversion kit, please follow all instructions included with the kit.

- The T-K3/T-K3-Pro must be installed in a location where the proper amount of combustible air will be available to it at all times without obstructions.
- If used as a direct vent appliance, the T-K3/T-K3-Pro requires a 3" combustible air supply pipe. The intake pipe must be sealed airtight.
- Air supply pipe can be made of ABS, PVC, galvanized steel, corrugated aluminum, corrugated stainless steel or Category III stainless steel.
- Change the dipswitch settings to the direct vent system. (See diagram below)
- Sidewall venting is recommended for the direct vent system.
- Takagi recommends running the exhaust vent and the intake pipe parallel.



**Make sure power to the unit is turned OFF before changing the dipswitch settings.**

The dark square is the direction the dipswitch should be set to.

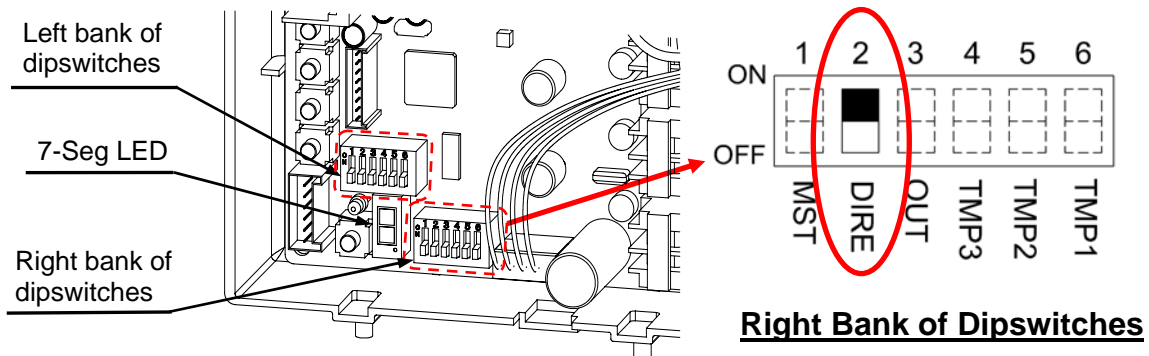

**TK-TV10 Direct Vent Conversion Kit**

**TK-TV10  
DIRECT VENT  
CONVERSION KIT**

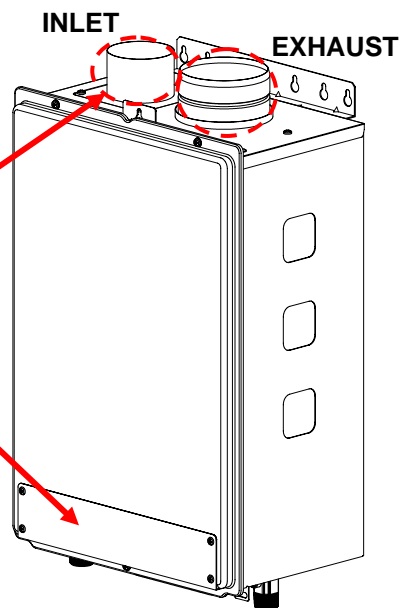

# VENTING INSTRUCTIONS



**WARNING:** Improper venting of this appliance can result in excessive levels of carbon monoxide which can result in severe personal injury or death.

This water heater must be vented in accordance with the section "Venting of Equipment" of the latest edition of the Natural Fuel Gas Code: The ANSI Z223.1, All applicable local building codes, Section 7 of the CAN/CSA B149.1 Natural Gas in Canada, Propane Installation Code in Canada.

## EXHAUST VENT

This is a Category III appliance and must be vented accordingly. The vent system must be sealed air tight. All seams and joints **without gaskets** must be sealed with high heat resistant silicone sealant or UL listed aluminum adhesive tape having a minimum temperature rating of 350°F. For best results, a vent system should be as short and straight as possible.

1. This Takagi water heater is a Category III appliance and must be vented accordingly with any 4" vent approved for use with Category III or Special BH type gas vent.
2. **TAKAGI recommends the "T-Vent" line manufactured by TAKAGI** (Refer to Takagi's "T-Vent" brochure for details). However, the following are also UL listed manufacturers: ProTech Systems Inc. (FasNSeal), Flex-L Inc., Z-Flex Inc. (Z-Vent III), Metal-Fab Inc., and Heat-Fab Inc. (Saf-T Vent).
3. **Follow the vent pipe manufacturer's instructions when installing the vent pipe.**
4. **Do not common vent this appliance with any other vented appliance** (Do not terminate vent into a chimney. If the vent must go through the chimney, the vent must run all the way through the chimney with Category III approved or Special BH vent pipe).
5. The maximum length of exhaust vent piping must not exceed 50 ft. deducting 5 ft. for each elbow used in the venting system. Do not use more than 5 elbows.

Diameter	Max. No. of Elbow	Max. Vertical or Horizontal run in Length
4"	5 Ea.	50 ft.

**\*For each elbow added, deduct 5 ft. from max. Vent length.**

No. of Elbows	Max. Vertical or Horizontal Length
0	50 ft.
1	45 ft.
2	40 ft.
5	25 ft.

6. When the horizontal vent run exceeds 5 ft., support the vent run at 3 ft. intervals with overhead hangars.
7. Takagi will not be responsible for any damage to the water heater caused by condensation from the vent. Installing a condensate drip is recommended. Please refer to p. 13 for the diagrams.



When installing the vent system, all applicable national and local codes must be followed. If you install thimbles, fire stops or other protective devices and they penetrate any combustible or noncombustible construction, be sure to follow all applicable national and local codes.

## VENT TERMINATION



**WARNING:** Improper installation can cause nausea or asphyxiation, severe injury or death from carbon monoxide and flue gases poisoning. Improper installation will void product warranty.

- The vent terminator provides a means of installing vent pipe through the building wall and must be located in accordance with ANSI Z223.1/NFPA 54, or in Canada with CAN/CSA-B149.1 and local applicable codes.
- A proper sidewall vent terminator is recommended when the water heater is vented through a sidewall. If the T-K3/T-K3-Pro is converted to a direct-vent unit, a proper sidewall direct-vent terminator is to be used.

### General rules for venting the T-K3/T-K3-Pro water heater are:

1. Place the water heater as close as possible to the vent terminator.
2. The vent collar of the water heater must be fastened directly to an unobstructed vent pipe.
3. Do not weld the vent pipe to the water heater collar.
4. Do not cut the vent collar of the unit.
5. The weight of the vent stack must not rest on the water heater.
6. The vent must be easily removable from the top of the water heater for normal service and inspection of the unit.
7. The water heater vent must not be connected to any other gas appliance or vent stack.
8. Avoid locating the water heater vent terminator near **any air intake devices**. These fans can pick up the exhaust flue products from the water heater and return them to the building. This can create a health hazard.
9. Avoid using an oversized vent pipe or using extremely long runs of the pipe.
10. Locate the vent terminator so that it cannot be blocked by any debris, at any time. Most codes require that the terminator be at least 12 inches above grade, but the installer may determine if it should be higher depending on the job site condition and applicable codes.
11. For rooftop venting, a rain cap must be installed.
12. **TAKAGI recommends the “T-Vent” line manufactured by TAKAGI** (Refer to Takagi’s “T-Vent” brochure for details). However, the following are also UL listed manufacturers: ProTech Systems Inc. (FasNSeal), Flex-L Inc., Z-Flex Inc. (Z-Vent III), Metal-Fab Inc., and Heat-Fab Inc. (Saf-T Vent).

### Horizontal Installation Diagram

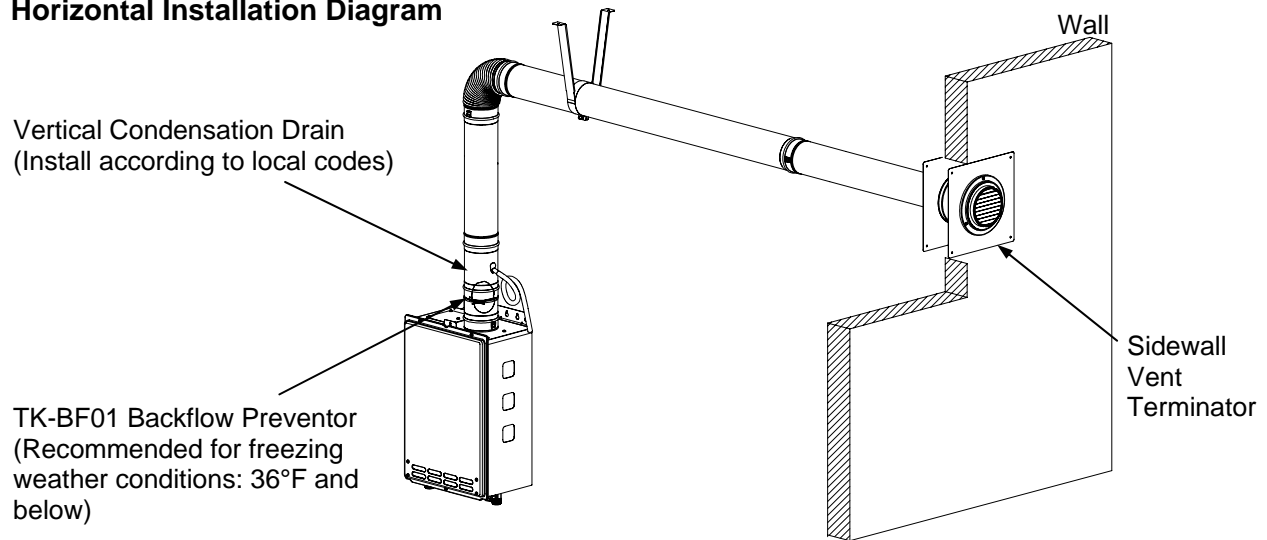

### Vertical Installation Diagram

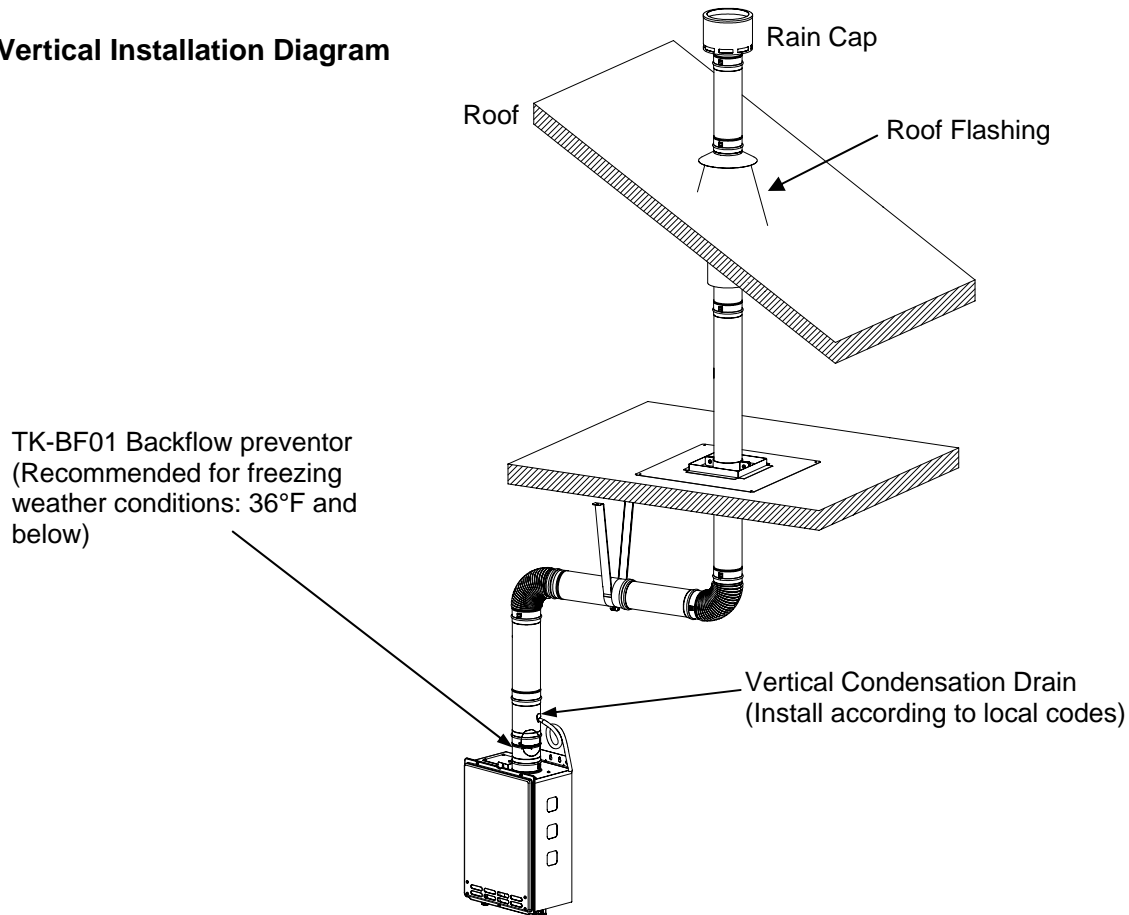

- Regarding the clearance from the terminator to the air inlet or opening, refer to the next page.
- Install a condensation drain in the venting.
- Follow the vent system to vent manufacturer's instruction and local code.
- Do not common vent or connect any vent from other appliances to the T-K3/T-K3-Pro vent.
- Use 4" category III approved or Special BH, single or double wall stainless steel vent pipe.

# VENT CLEARANCES

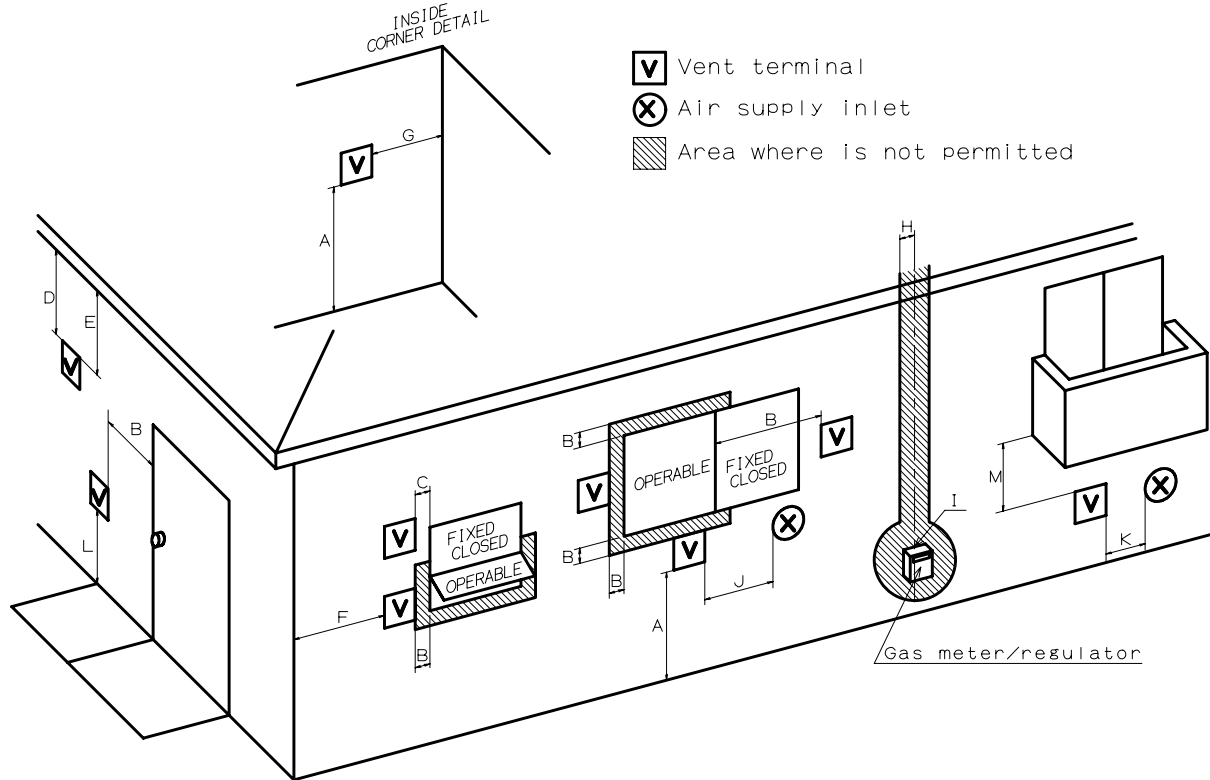

		Canada	U.S.A	
		Direct vent and other than Direct Vent	Direct vent	Other than Direct Vent
A	Clearance above grade, veranda, porch, deck, or balcony.	1 foot	1 foot	1 foot
B	Clearance to window or door that may be opened.	3 feet	1 foot	4 feet from below or side opening. 1 foot from above opening.
C	Clearance to permanently closed window	*	*	*
D	Vertical clearance to ventilated soffit located above the vent terminator within a horizontal distance of 2 feet (61cm) from the center line of the terminator.	*	*	*
E	Clearance to unventilated soffit	*	*	*
F	Clearance to outside corner	*	*	*
G	Clearance to inside corner	*	*	*
H	Clearance to each side of center line extended above meter/regulator assembly	3 feet	*	*
I	Clearance to service regulator vent outlet.	3 feet	*	*
J	Clearance to non-mechanical air supply inlet to building or the combustion air inlet to any other application.	3 feet	1 foot	4 feet from below or side opening. 1 foot from above opening.
K	Clearance to mechanical air supply inlet.	6 feet	3 feet	3 feet
L	Clearance above paved sidewalk or paved driveway located on public property.	7 feet	*	7 feet
M	Clearance under veranda, porch deck, or balcony.	1 foot	*	*

\*For clearances not specified in ANSI Z223.1 / NFPA 54 or CAN/CSA-B149.1, please use clearances in accordance with local installation codes and the requirement of the gas supplier.

## ADDITIONAL CLEARANCES

Please follow all local and national codes in regards to proper termination clearances. In the absence of such codes, the following clearances can be used as guidelines. Local codes supersede these guidelines.

### For sidewall terminations

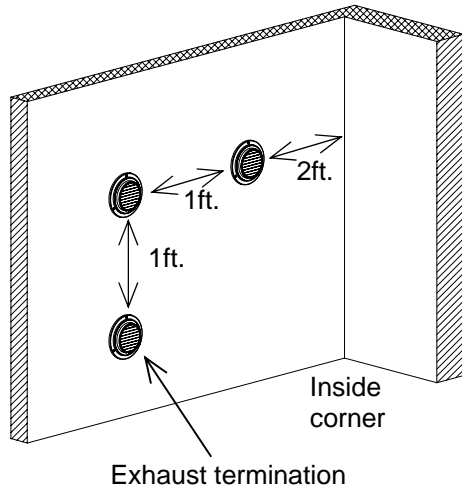

For multiple sidewall exhaust terminations (e.g. multi-unit systems), an exhaust termination must be at least 1 ft. away from another exhaust termination. An exhaust termination must also be at least 2 ft. away from an inside corner (if the adjacent wall is less than 2 ft. of length, the minimum required distance away from the inside corner will be equal to the length of the wall).

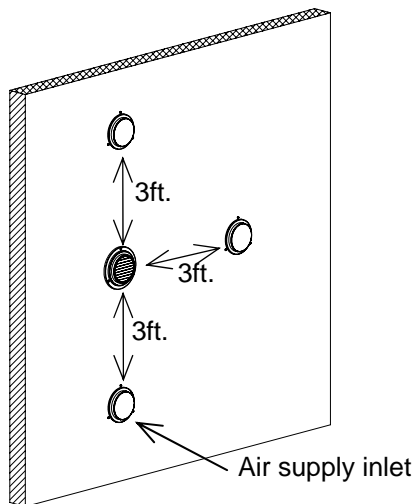

For direct-vent sidewall terminations that use two separate penetrations for the intake and exhaust, distance the intake and exhaust terminations at least 3 ft. away from each other, no matter the orientation.

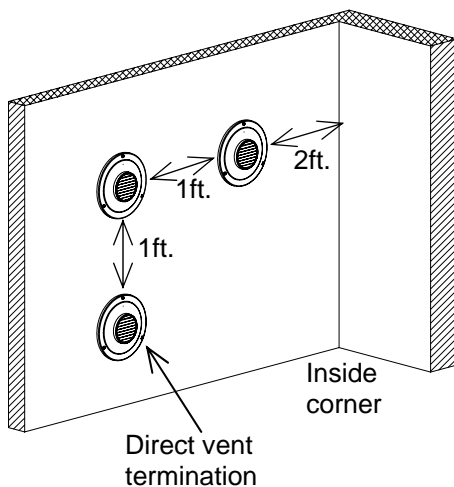

For multiple-unit, direct-vent sidewall terminations that combine the intake and exhaust into a single penetration, space each direct-vent termination at least 1 ft. away from each other, no matter the orientation. A direct-vent termination must also be at least 2 ft. away from an inside corner (if the adjacent wall is less than 2 ft. of length, the minimum required distance away from the inside corner will be equal to the length of the wall).

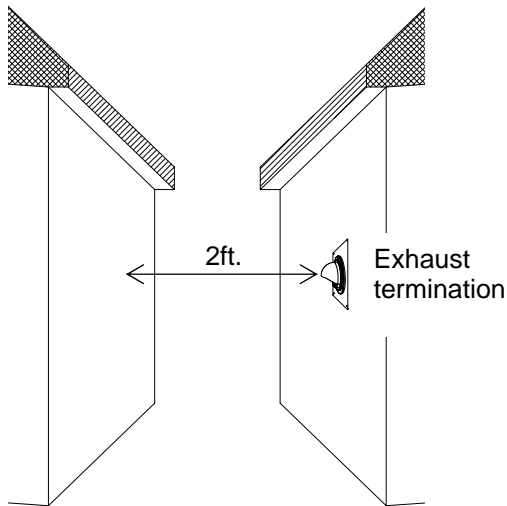

Exhaust and/or direct-vent sidewall terminations should be at least 2 ft. away from an opposite surface/wall. Do not place the termination directly in front of an opening into a building.

**For rooftop terminations**

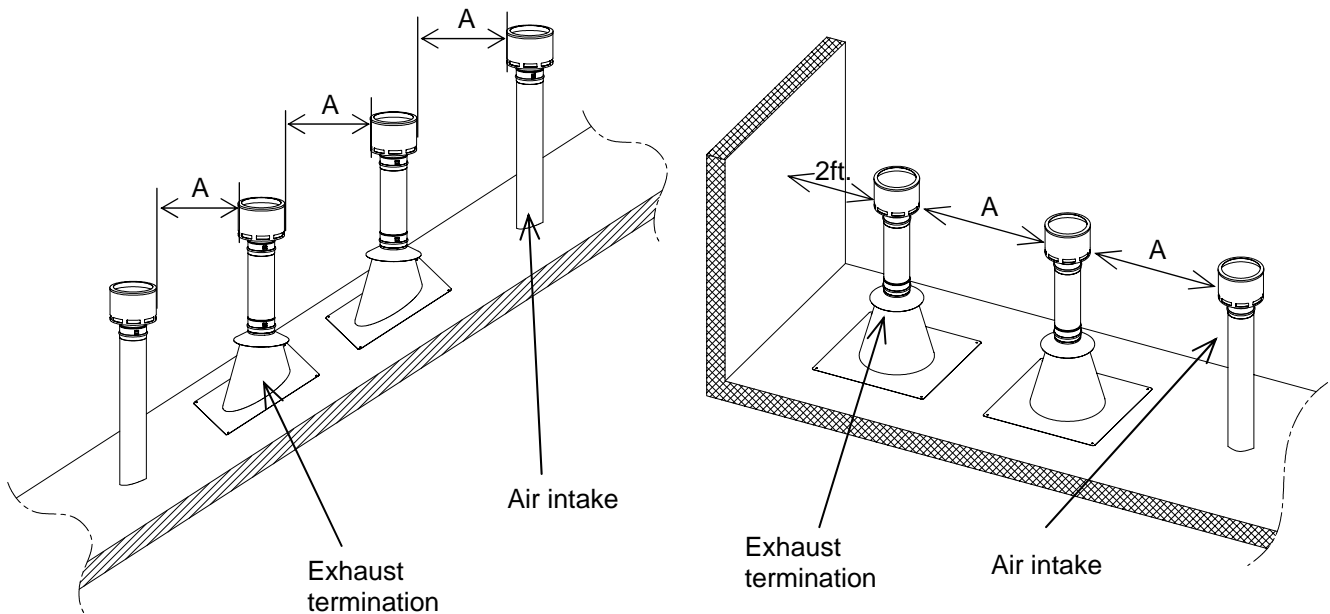

A: in accordance with local codes

For multiple-unit rooftop terminations (whether for standard indoor or direct-vent installations) space all exhaust and intake terminations in accordance with local codes. An exhaust termination must be spaced from a wall or surface in accordance with local codes as well. In the absence of such a code, an exhaust termination must be a horizontal distance of at least 2 ft. away from a wall or surface.



# GAS SUPPLY AND GAS PIPE SIZING

## TO TURN OFF GAS TO APPLIANCE

1. Turn off all electric power to the water heater if service is to be performed.
2. Turn the manual gas valve located on the outside of the unit clockwise  $\curvearrowright$  to the off position.



**WARNING:** Conversion of this unit from natural gas to propane or vice versa cannot be done in the field. Contact your local distributor to get the correct unit for your gas type. Conversion done by anyone other than the manufacturer will void all warranty. **Takagi is not liable for any property and/or personal damage resulting from unauthorized conversions.**

**\*Check that the type of gas matches the rating plate first.**

1. The minimum and maximum inlet gas pressures are:

Natural Gas	Min. 5.0" WC - Max. 10.5" WC
Propane Gas	Min. 8.0" WC - Max. 14.0" WC

2. Gas pressure below this specified range for the T-K3/T-K3-Pro and/or insufficient gas volume will adversely affect performance. These pressures are measured when the T-K3/T-K3-Pro is in full operation.
3. Inlet gas pressure must not exceed the above maximum values; gas pressure above the specified range will cause dangerous operating conditions and damage to the unit. Ensure that any and all gas regulators used are operating properly and are providing gas pressures within the specified range shown above.
4. Until testing of the main gas line supply pressure is completed, ensure the gas line to the T-K3/T-K3-Pro is disconnected to avoid any damage to the water heater.

## MEASURING INLET GAS PRESSURE

The T-K3/T-K3-Pro cannot perform properly without sufficient inlet gas pressure. Below are instructions on how to check the inlet gas pressure. **THIS IS ONLY TO BE DONE BY A LICENSED PROFESSIONAL.**

1. Shut off the manual gas valve on the supply gas line.
2. Open a faucet. The unit should turn on and the gas in the gas pipe line should purge. Leave the faucet on to keep the unit running until the unit shut down due to lack of gas supply. Then shut the faucet off.
3. Remove the screw for the pressure port located on the gas inlet of the T-K3/T-K3-Pro shown in the diagram to the right.
4. Connect the manometer to the pressure port.
5. Re-open the manual gas valve. Check to see that there are no gas leaks.
6. Open some of the fixtures that use the highest flow rate to turn on the T-K3/T-K3-Pro.
7. Check the inlet gas pressure. When T-K3/T-K3-Pro is on a maximum burn, the manometer should read from 5.0" to 10.5" WC for Natural gas, from 8.0" to 14.0" WC for Liquid Propane.

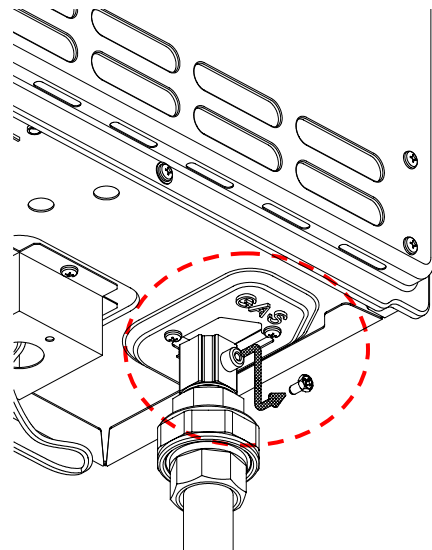



Size the gas pipe appropriately to supply the necessary volume of gas required for the T-K3/T-K3-Pro (199,000 BTUH for both Natural Gas and Liquid Propane) using ANSI233.1/NAPA 54 in the USA or CAN/CSA B149.1 in Canada or local codes. Otherwise, flow capabilities and output temperatures will be limited.

1. Install a manual gas shut-off valve between the T-K3/T-K3-Pro and the gas supply line.
2. When the gas connections are completed, it is necessary to perform a gas leak test either by applying soapy water to all gas fittings and observing for bubbles or by using a gas leak detection device.
3. Always purge the gas line of any debris and/or water before connecting to the gas inlet.

## Natural Gas Supply Piping

Maximum Delivery Capacity of Cubic Feet of Gas per Hour of IPS Pipe Carrying Natural Gas of 0.60 Specific Gravity Based on Pressure Drop of 0.5" WC

Based on Energy Content of 1000 BTU/Cubic Ft.: T-K3/T-K3-Pro requires 199 Cubic Ft./hr.

Unit: Cubic Feet per Hour

Pipe Size inches	Length in Feet												
	10'	20'	30'	40'	50'	60'	70'	80'	90'	100'	125'	150'	200'
3/4"	363	249	200	171	152	138	127	118	111	104	93	84	72
1"	684	470	377	323	286	259	239	222	208	197	174	158	135
1 1/4"	1404	965	775	663	588	532	490	456	428	404	358	324	278
1 1/2"	2103	1445	1161	993	880	798	734	683	641	605	536	486	416
2"	4050	2784	2235	1913	1696	1536	1413	1315	1234	1165	1033	936	801

## Propane (LP) Gas Supply Piping

Maximum Capacity of Propane (LP) Gas Based on 11" WC supply pressure at a 1.0" WC pressure drop

Unit: kBtu per Hour

Pipe Size inches	Length in Feet												
	10'	20'	30'	40'	50'	60'	70'	80'	90'	100'	125'	150'	200'
3/4"	567	393	315	267	237	217	196	185	173	162	146	132	112
1"	1071	732	590	504	448	409	378	346	322	307	275	252	213
1 1/4"	2205	1496	1212	1039	913	834	771	724	677	630	567	511	440
1 1/2"	3307	2299	1858	1559	1417	1275	1181	1086	1023	976	866	787	675
2"	6221	4331	3465	2992	2646	2394	2205	2047	1921	1811	1606	1496	1260

### Gas Sizing Example (Natural Gas)

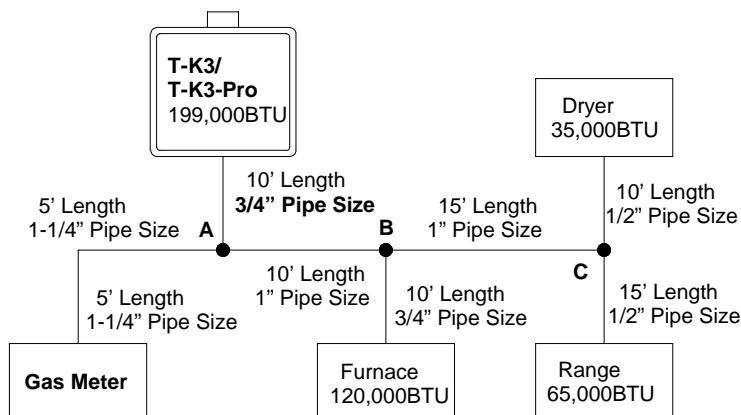

Based on Energy Content of 1000BTU/Cubic Ft:

Divide each appliance's BTU requirement by 1000BTU to get the appliances Cubic Ft. requirement.

Takagi into account the distance the appliance is from the gas meter, look in the above gas chart to properly size the line.

For sections of the gas line supplying gas to more than one appliance (Ex: Point A to Point B), add up the cubic ft. requirements of the appliances that are being supplied by that section, and size to the farthest appliance.

For Example: The section from A to B supplies gas to the furnace, range, and dryer. Adding up the BTU requirements and dividing by 1000 yields a cubic ft. requirement of 220 cubic ft. of gas. The farthest appliance is the range, which is 50 ft. away from the meter. Looking at the above chart, and under the column of 50ft., Section A to B needs to be 1" in order to supply 220 cubic ft.

## WATER CONNECTIONS

### FOR YOUR SAFETY, READ BEFORE OPERATING:

Do not use this water heater if any part has been submersed under water. Immediately call a licensed professional to inspect the water heater and to replace any damaged parts.

1. All pipes, pipe fittings, valves and other components, including soldering materials, must be suitable for potable water systems.
2. A manual shut off valve must be installed on the cold water inlet to the water heater between the main water supply line and the T-K3/T-K3-Pro.
3. In addition, a manual shut off valve is also recommended on the hot water outlet of the unit. If the T-K3/T-K3-Pro is installed within, or subjected to, a closed loop water system, a thermal expansion tank must be installed.
4. **Before installing the water heater, flush the water line to remove all debris, and after installation is complete, purge the air from the line. Failure to do so may cause damage to the heater.**
5. There is a wire mesh filter within the cold inlet to trap debris from entering your heater. This will need to be cleaned periodically to maintain optimum flow.



**CAUTION:** Do not reverse the hot outlet and cold inlet connections to the T-K3/T-K3-Pro Water Heater. This will not properly activate the water heater.

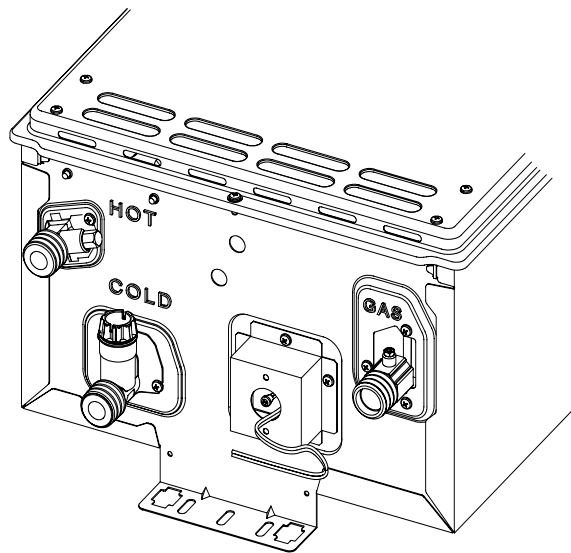

## PRESSURE RELIEF VALVE

The Flash T-K3/T-K3-Pro has a high-temperature shut off switch built in as a standard safety feature (called a Hi-Limit switch) therefore a “**pressure only**” relief valve is required.

1. This unit does not come with an approved pressure relief valve.
2. An approved pressure relief valve must be installed on the hot water outlet.
3. The pressure relief valve must conform to ANSI Z21.22 or CAN 1-4.4 and installation must follow local code.
4. The discharge capacity must be at least 199,000 BTU/hr.
5. The pressure relief valve needs to be rated for a maximum of 150 psi.
6. The discharge piping for the pressure relief valve must be directed so that the hot water cannot splash on anyone or on nearby equipment.
7. Attach the discharge tube to the pressure relief valve and run the end of the tube to within 6" from the floor. This discharge tube must allow free and complete drainage without any restrictions.
8. If the pressure relief valve installed on the T-K3/T-K3-Pro discharges periodically, this may be due to a defective thermal expansion tank or defective pressure relief valve.
9. The pressure relief valve must be manually operated periodically to check for correct operation.

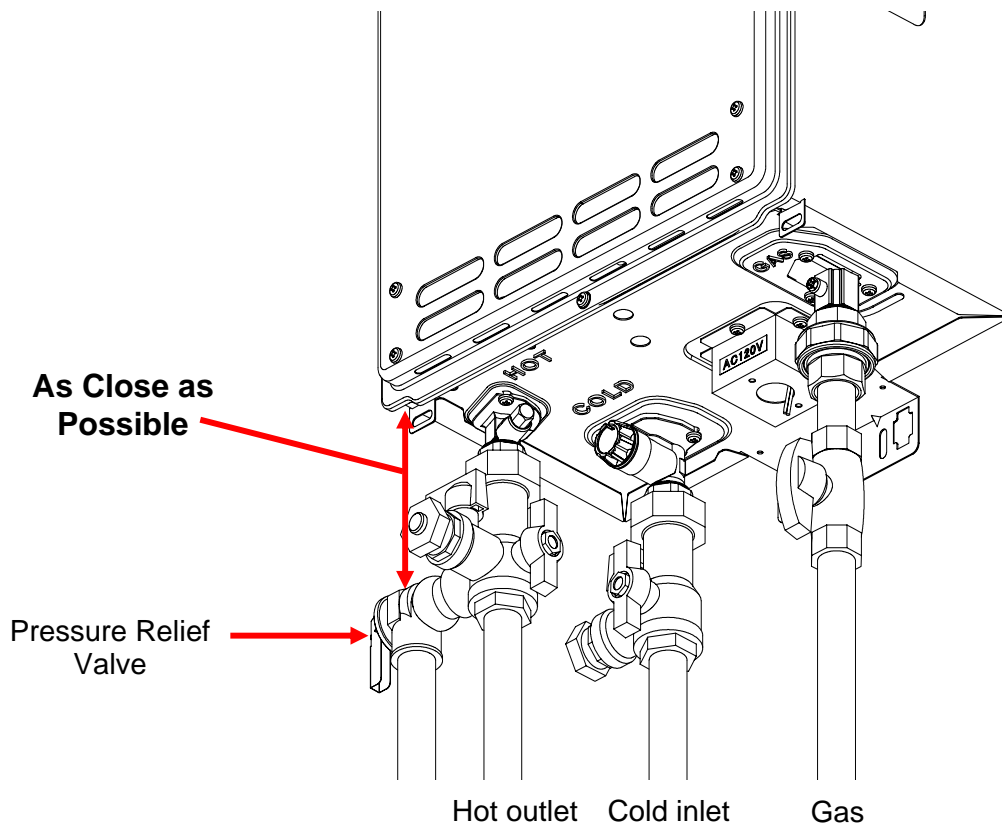

## ELECTRICAL CONNECTIONS

**WARNING:** Follow the electrical code requirements of the local authority having jurisdiction. In the absence of such requirements, follow the latest edition of the National Electrical Code ANSI/NFPA 70 in the U.S. or the latest edition of CSA C22.1 Canadian Electrical Code, Part 1, in Canada.

**CAUTION:** When servicing or replacing parts within the T-K3/T-K3-Pro, label all wires prior to disconnection to facilitate an easy and error-free reconnection. Wiring errors can cause improper and dangerous operation. Verify proper operation after servicing.

1. The heater must be electrically grounded. Do not attach the ground wire to either the gas or the water piping.
2. The Flash T-K3/T-K3-Pro water heater requires **AC 120V 60 Hz electrical power supply that is properly grounded.**
  - A proper disconnect (i.e. on/off switch, power plug, etc.) controlling the main power to the T-K3/T-K3-Pro must be provided for service reasons. (Must comply with local codes).
  - Connect the power supply to the T-K3/T-K3-Pro exactly as shown in the wiring diagram;
3. A green screw is provided in the junction box to ground the connection.
4. Can be hardwired or wired to a plug-in.
5. The use of a surge protector is recommended in order to protect the unit from power surges.

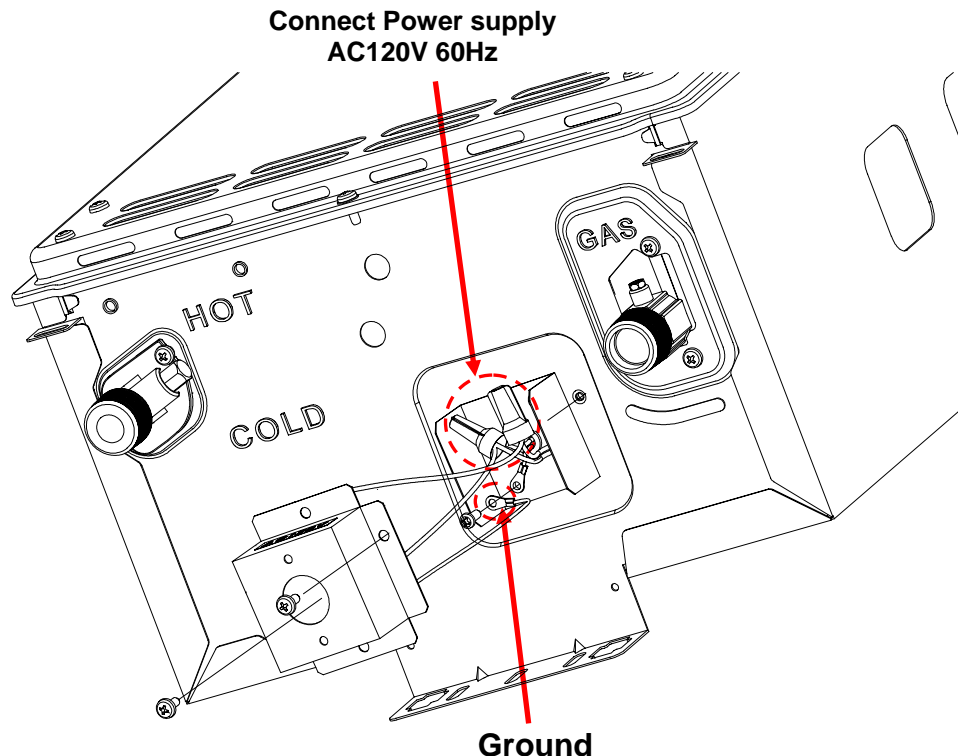

# REMOTE CONTROLLER CONNECTION

- 1) Disconnect power supply from the T-K3/T-K3-Pro.
- 2) Take off the T-K3/T-K3-Pro's front cover.
- 3) Please find the remote control terminal using the picture below (located around the lower right-hand side of the computer board).
- 4) Open the plastic cover of the TM-RE30, and then attach the fork terminal to the connector base of the backside the TM-RE30 with two screws. Make sure the terminals are firmly fixed.
- 5) Put the remote wires through the hole on the bottom of the unit casing.
- 6) Connect the remote wires to the remote controller terminal properly. (No polarity)
- \*Do NOT jump or short-circuit wires. Computer will be damaged.**
- 7) Replace Front Cover securely.
- 8) Wires used for the remote controller connection must be:

- Minimum 18AWG wire (No polarity)
- Maximum 400 feet long

\*For details on the connection to the TM-RE30, refer to the TM-RE30's Installation Manual.

## Remote controller terminal inside T-K3/T-K3-Pro

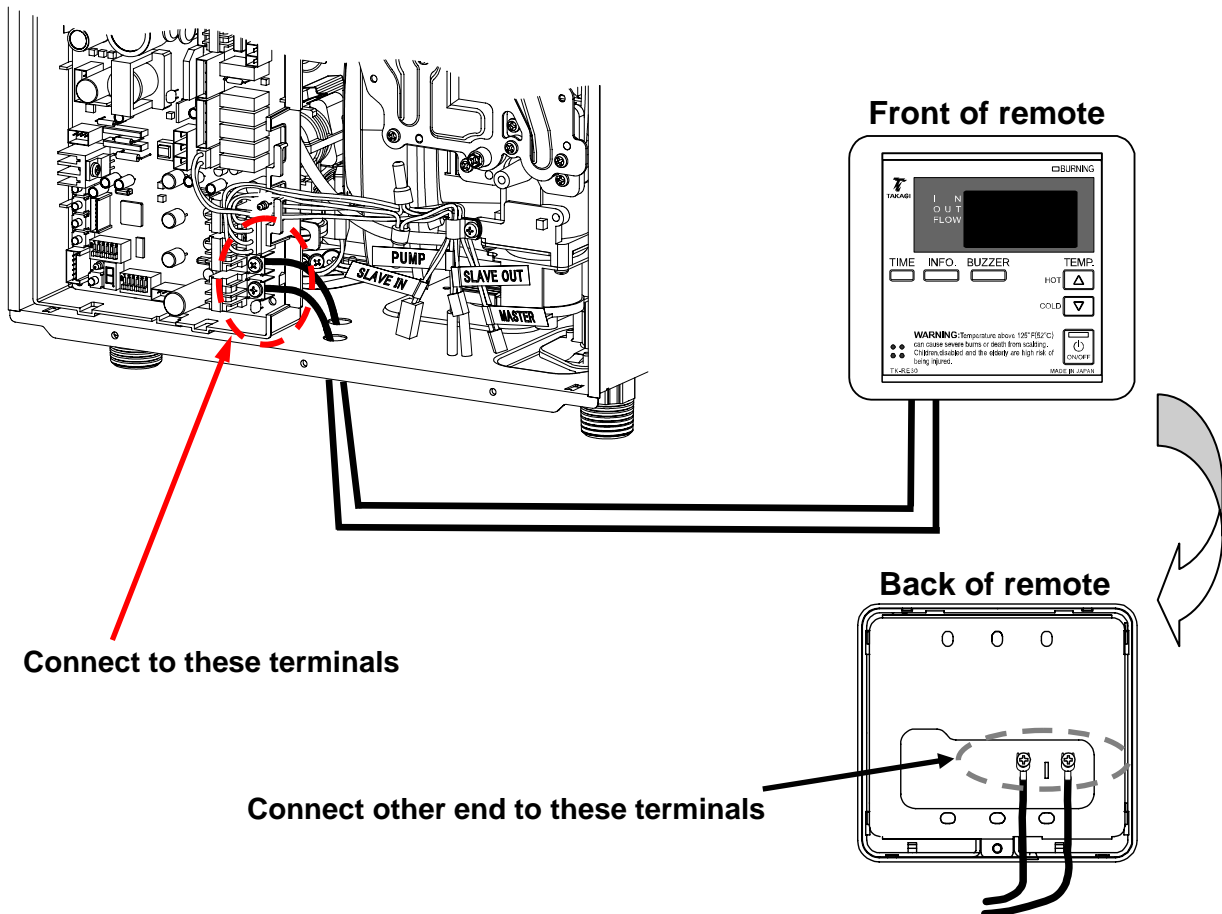

## EASY LINK SYSTEM

The T-K3/T-K3-Pro can be connected with other T-K3/T-K3-Pro's with communication cables to work as a multiple manifold system.

- The Easy Link system can connect up to 4 units.
- A communication cable (gray color) comes with each unit.

You can manifold from 2 units to 4 units without a multi-system controller. A 4-unit system has full automatic modulation between 11,000 BTU and 796,000 BTU.

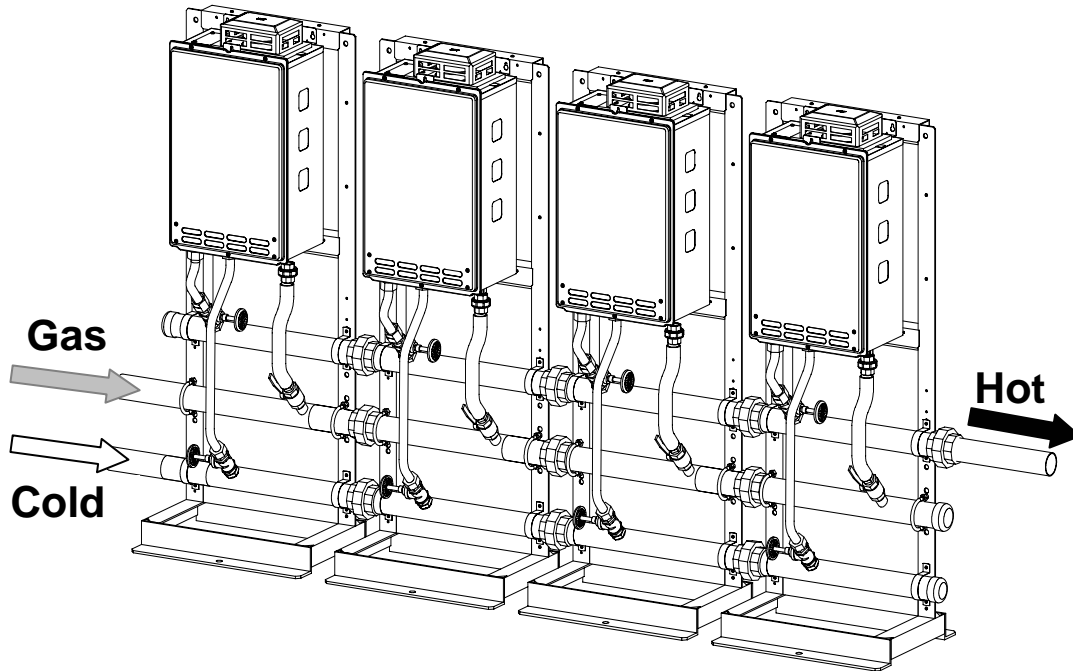

### CAUTION

- The T-K3/T-K3-Pro Easy Link system is limited to **4 units**. If you connect more than 4 units, the first 4 units will work as a part of the Easy Link system, but the other additional units will only work as individual units.
- The T-K3/T-K3-Pro cannot be linked with other different Takagi models in the Easy Link system.

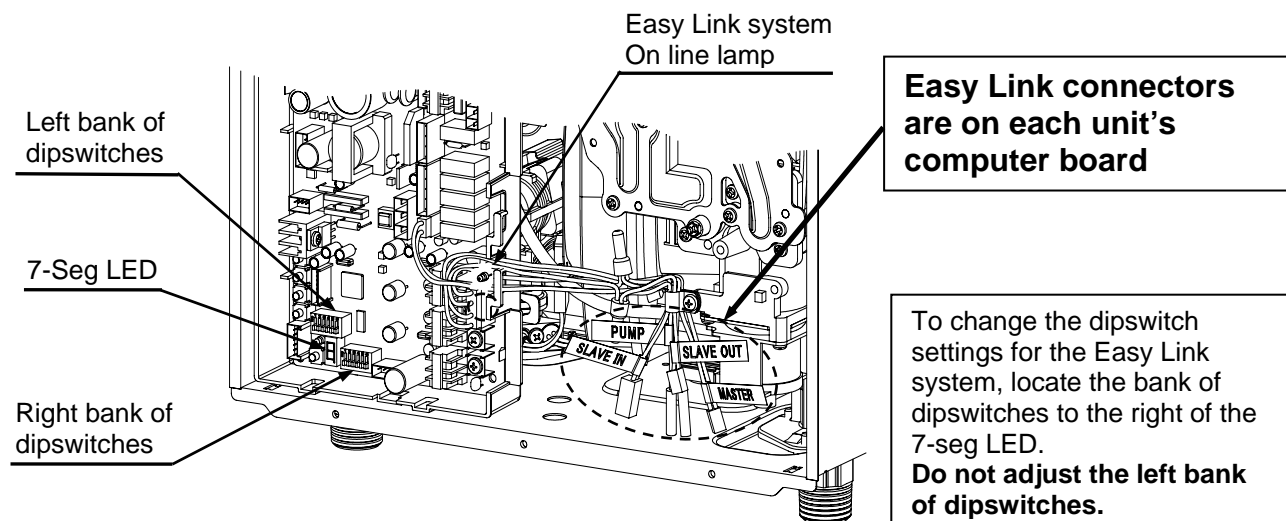

## Easy Link Connection Procedures

1. Choose one of your units as the **“MASTER”** unit.

### 2. **“The MASTER”**

Locate the bank of dipswitches to the right of the 7-seg. LED on the computer board of the T-K3/T-K3-Pro that you select to be the **“MASTER”** unit. Change dipswitch No. 1 to **“ON”**. Do not change any dipswitch settings on the **“SLAVE”** units.

### 3. Between the **“MASTER”** and the **“SLAVE-1”**

Connect the **“MASTER connector”** of the **“MASTER”** unit to the **“SLAVE IN connector”** of the **“SLAVE-1”** unit.

### 4. Between the **“SLAVE-1”** and the **“SLAVE-2”**

Connect the **“SLAVE OUT connector”** of the **“SLAVE-1”** unit to the **“SLAVE IN connector”** of the **“SLAVE-2”** unit.

### 5. Between the **“SLAVE-2”** and the **“SLAVE-3”**

Connect the **“SLAVE OUT connector”** of the **“SLAVE-2”** unit to the **“SLAVE IN connector”** of the **“SLAVE-3”** unit.

6. Make sure the **“Easy Link system ON LINE”** lamps of all units are lit. The numbering system of the T-K3/T-K3-Pro automatically allocates the unit # to each water heater that is part of the Easy Link system.

Master unit	Unit # : 1
Slave units	Unit# : 2, 3 and 4

The dark squares indicate the direction the dipswitches should be set to.

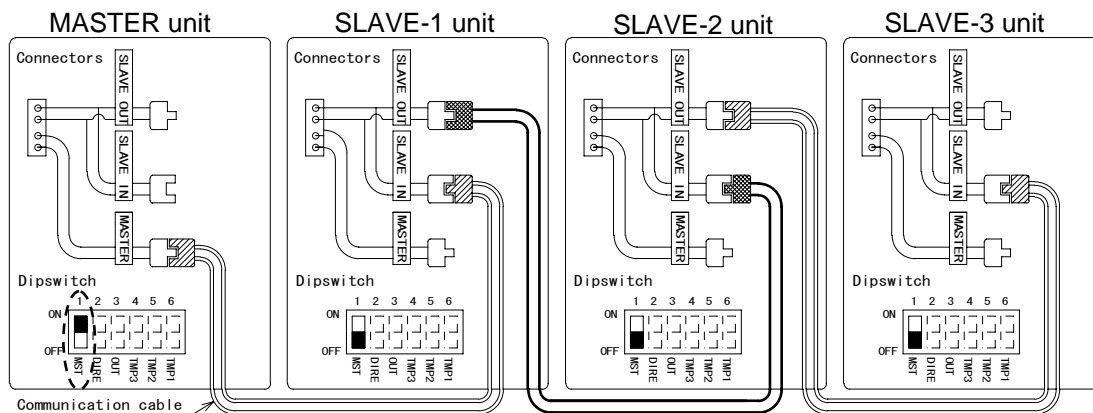

## CAUTION

- Unless you change dipswitch No.1 of the **“MASTER”** unit to **“ON”**, the system will not work as an Easy Link system. The **“Easy Link system ON LINE”** lamps will stay unlit and the units will work as individual units.



Wrong dipswitch setting on the **“MASTER”** unit

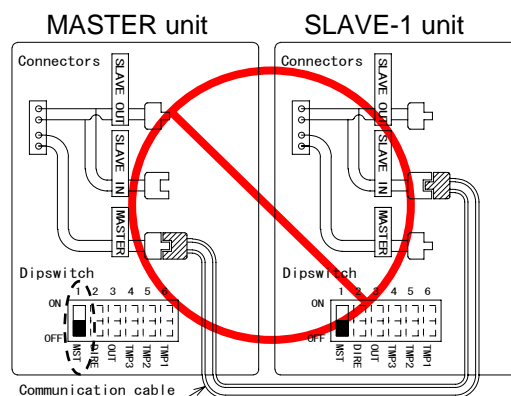



## CAUTION

- If you connect the “**SLAVE IN** (or **SLAVE OUT**) connector” of the “**MASTER**” unit to the “**MASTER** (or **SLAVE IN**) connector” of the “**SLAVE-1**” unit, the system will not work as a easy link system. The “**ON LINE**” lamps will stay unlit and the units will work as individual units.



Wrong connection between the “**MASTER**” unit and the “**SLAVE-1**” unit

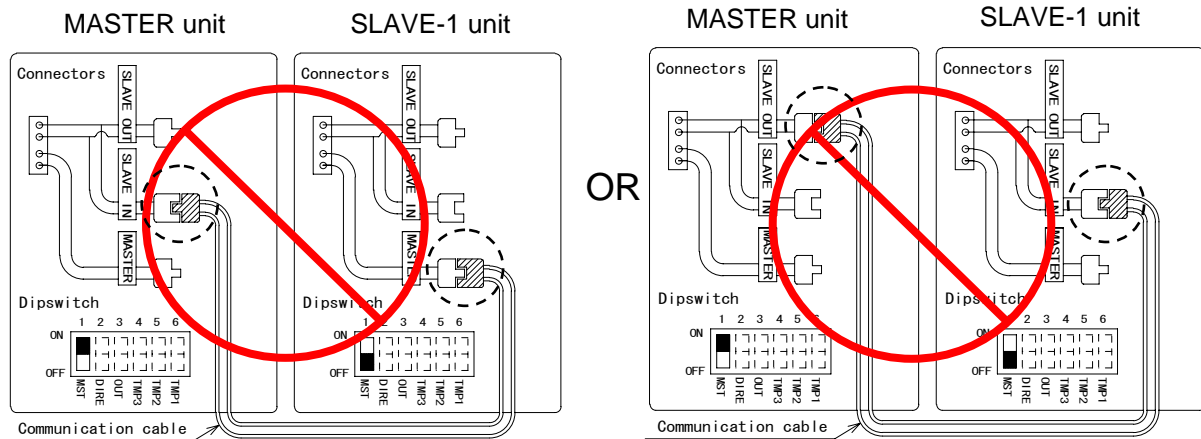

- If you connect the “**MASTER** connector” of the “**SLAVE-1**” unit to the “**SLAVE IN** connector” of the “**SLAVE-2**” unit, the “**SLAVE-2**” unit will work as an individual unit, and will not be part of the easy link system.



Wrong connection between the “**SLAVE-1**” unit and the “**SLAVE-2**” unit

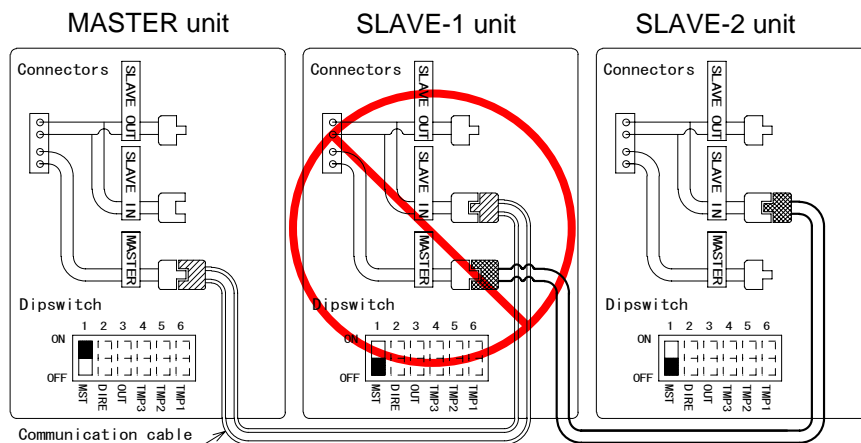

## WARNING

Connecting two “**MASTER** connectors” together from two separate units **may damage the computer board**. The communication cable has a female end and a male end so it's impossible to have a **MASTER -to- MASTER** connection with the communication cable. Do not splice or modify connectors.



**Prohibited**

- If the TM-RE30 or the TM-RE10 remote controller (optional) has to be connected to the “MASTER” unit. If the TM-RE30 or the TM-RE10 is connected to a “SLAVE” unit, it will only control that particular individual “SLAVE” unit and will not control the Easy Link system as a whole.

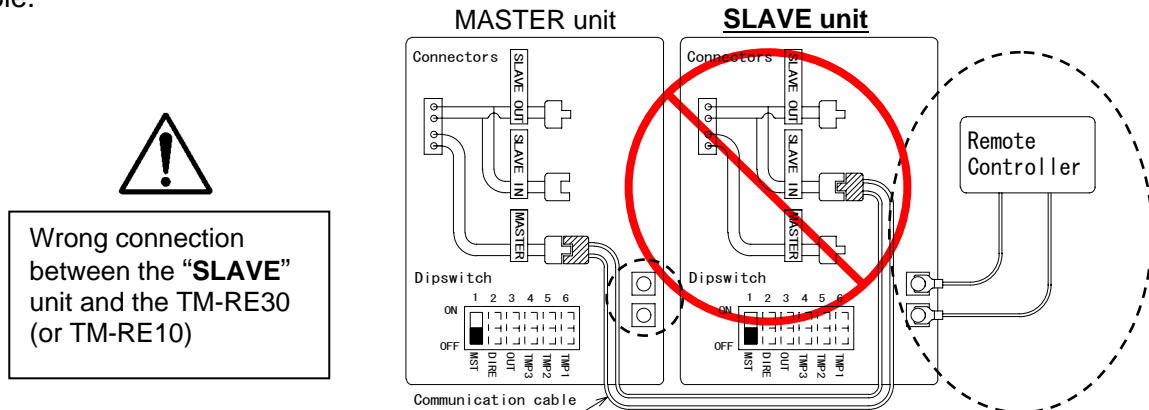

- 
- The TM-RE30 or TM-RE10 (optional remote controller) is not required for the Easy Link system.
  - If running the Easy Link system without the TM-RE30 or the TM-RE10, please make sure the dipswitch settings for the temperature, outdoor, and direct vent settings on ALL the units are set to the same settings. Otherwise, the units may not operate properly.
  - If the TM-RE30 or the TM-RE10 is used, the temperature on all the units in the system will automatically be set to the same temperature that is set on the remote. However, even with the remote, the outdoor and direct vent dipswitch settings still need to be set to the same settings on all the units.

## PUMP CONNECTION

The T-K3/T-K3-Pro can be used to control a recirculation pump. Proper pump control helps to preserve the life of the system and saves energy as well: The T-K3/T-K3-Pro pump control port is a “normally open” dry contact, and therefore needs additional components to properly control a recirculation pump. To control a recirculation pump, connect the pump to the “Pump” connector in the T-K3/T-K3-Pro as shown in the diagram to the right. (In an Easy Link system, connect the pump ONLY to the “MASTER” unit.) The pump is to be connected using suitable relays shown in the diagram below. **Please make sure the relays are properly rated for the recirculation pump.**

Using the T-K3/T-K3-Pro’s internal thermistors as a temperature control, the recirculation pump will only turn on when recirculation is needed.

### CAUTION

**In an Easy Link system, the pump must be connected to the “Pump” connector in the “MASTER” unit only.** If the pump is connected to any of the “SLAVE” units, the pump will not work.

**Connect to this “Pump” connector.**

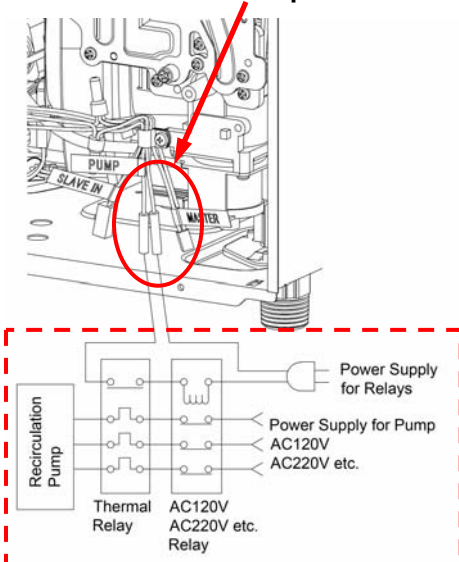

These components are not included with Takagi water heaters and are external to the unit. They must be acquired separately.

# INITIAL OPERATION

## FOR YOUR SAFETY, READ BEFORE OPERATING:

- **Check the GAS and WATER CONNECTIONS** for leaks before firing it for the first time.
- Open the main gas supply valve to the unit using only your hand to avoid any spark. Never use tools. If the knob will not turn by hand, do not try to force it; call a qualified service technician. Forced repair may result in a fire or explosion due to gas leaks.
- Be sure to check next to the bottom of the unit because some gases are heavier than air and may settle towards the floor.
- **Check the GAS PRESSURE.** Refer to p. 17.
- Do not try to light the burner manually. It is equipped with an electronic ignition device which automatically lights the burner.
- **Check for PROPER VENTING and COMBUSTIBLE AIR** to the heater.
- **Purge the GAS and WATER LINES** to remove any air pocket.
- Do not use this water heater if any part has been submersed under water. Immediately call a qualified service technician to inspect the water heater and to replace any damaged parts.

### CAUTION: IF YOU SMELL GAS:

- Do not try to start the water heater.
- Do not touch any electric switch; do not use any phone in your building.
- Immediately call your gas supplier from a neighbor's phone. Follow the gas supplier's instructions.
- If you cannot reach your gas supplier, call the fire department.

1. Once the above checks have been completed, please clean filter of any debris. Refer to p. 31 for instructions.



2. Fully open the manual water control valve on the water supply line.



3. Open a hot water tap to verify that water is flowing to that tap.

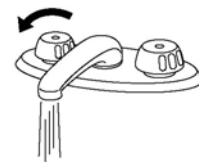

Then close the hot water tap.

4. Fully open the manual gas control valve installed.



5. Turn on the 120 volt 60 Hz power supply to the T-K3/T-K3-Pro water heater.

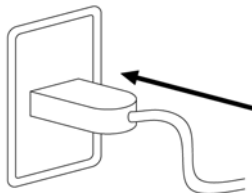

6. Now you are ready to enjoy hours of endless hot water.

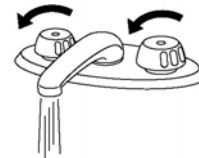

# NORMAL OPERATION



- Flow rate to activate the T-K3/T-K3-Pro : 0.5 gallon per minute
- Flow rate to keep the T-K3/T-K3-Pro running : 0.4 gallon per minute

## 1. NORMAL OPERATION WITHOUT REMOTE CONTROLLER

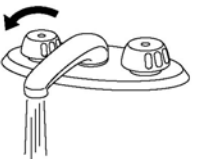
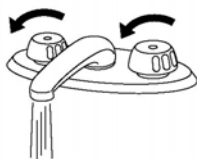
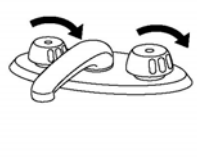
<p>1. Open a hot water tap.</p> 	<p>2. Mix cold water with the hot to get the correct temperature water.</p> 	<p>3. Close the hot water tap.</p> 
---	---	--

## 2. NORMAL OPERATION WITH REMOTE CONTROLLER INSTALLED: TM-RE30 (Optional)

### WITH REMOTE CONTROLLER INSTALLED: TM-RE30 (Optional)

\*If the TM-RE10 is used, refer to the TM-RE10 Installation Manual included with the remote.

1. Press the power ON/OFF button.

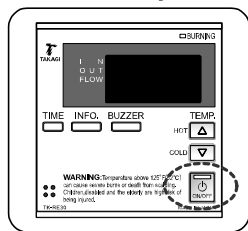

When ON, green LED is lit.

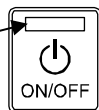

The temperature and the time will be displayed on the remote controller.

2. Set temperature. (Example 110°F)

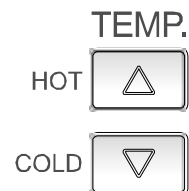
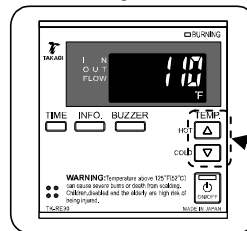

### Temperatures available under the Default Mode

99	100	102	104	106	108	110	111	113	115	117	122	131	140	158	167
----	-----	-----	-----	-----	-----	-----	-----	-----	-----	-----	-----	-----	-----	-----	-----

### Temperatures available under the High Temperature Mode

99	100	102	104	106	108	110	111	113	122	131	140	149	158	167	176/185
----	-----	-----	-----	-----	-----	-----	-----	-----	-----	-----	-----	-----	-----	-----	---------

- DO NOT set to 185 °F if you use your T-K3/T-K3-Pro in recirculation system. Refer to p.30 (unit:°F)
- Refer to the TM-RE30 Installation Manual to change the setting to the High Temperature mode.

3. Open a hot water tap.

Mix cold water with the hot if you need.

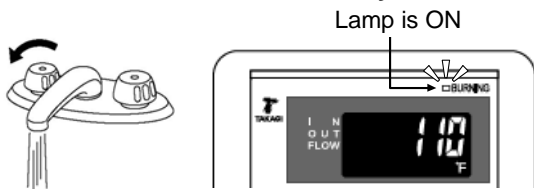

4. Close the hot water tap.

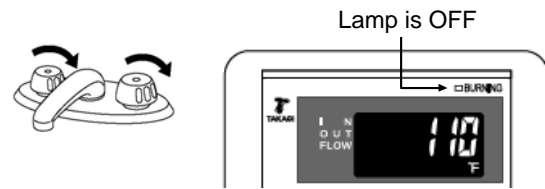

## WARNING

Hot Water temperatures over 125°F can cause severe burns instantly or death from scalding.

- The outlet hot water temperature of the FLASH T-K3/T-K3-Pro water heater is factory set at 122°F.
- Feel the water temperature before bathing or showering.

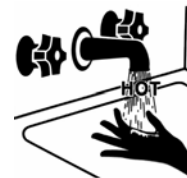

## FLOW

- The flow rate through the FLASH T-K3/T-K3-Pro is limited to a maximum of 7.0 GPM.
- The temperature setting, along with the supply temperature of the water will determine the flow rate output of the unit.
- Please refer to the temperature vs. gallons per minute chart on p. 46 to determine the likely flow rates based on your local ground water temperature and your desired outlet water temperature combination.
- Based on the United States Department of Energy method of testing water heater output, the T-K3/T-K3-Pro is rated for 252 gallons per hour (GPH) or 4.2 gallons per minute (GPM) for Natural Gas, and 264 GPH or 4.4 GPM for Liquid Propane, when raising the water temperature by 77°F (from 58°F to 135°F).
- Refer to the chart to the right for typical household plumbing fixture flow rates to determine what the FLASH T-K3/T-K3-Pro can do in a household application.

<b>Household Flow Rates</b>	
<b>Appliance / Use</b>	<b>Flow Rate (GPM)</b>
Lavatory Faucet	1.0
Bath Tub	4.0 – 10.0
Shower	2.0
Kitchen Sink	1.5
Dishwasher	1.5
Washing Machine	4.0

Taken from UPC 2006

## FREEZE PROTECTION SYSTEM

- This unit comes equipped with heating blocks to protect it against damages associated with freezing.
- For this freeze protection system to operate there has to be electrical power to the unit. Damage to the heat exchanger caused by freezing temperatures due to power loss is not covered under the warranty. In cases where power losses can occur, consider the use of a backup power supply.
- The freeze protection system will activate when the surrounding and/or outside temperatures drop below 36.5°F (2.5°C).
- In any areas subject to freezing temperatures, Takagi highly recommends installing the unit indoors. In such an installation, freezing issues can only occur if cold air enters through the venting into the heat exchanger, whether by negative pressures within the installation location or by strong outside winds. It is the installer's responsibility to be aware of these issues and take all preventative measures. Takagi will not be responsible for any damage to the heat exchanger as a result of freezing.
- Takagi also highly recommends the use of a back flow vent damper and/or converting the T-K3/T-K3-Pro to a direct-vent unit to minimize the amount of cold air entering through the exhaust venting when the water heater is off.
- If you will not be using your heater for a long period of time:
  1. Completely drain the unit of water. Refer to p. 31.
  2. Disconnect power to your heater.

This will keep your unit from freezing and being damaged.

**CAUTION:** Only pipes within the water heater are protected by the freeze protection system. Any water pipes (hot or cold) located outside the unit will not be protected. Properly protect and insulate these pipes from freezing.

# TEMPERATURE SETTINGS

- There are 8 preset temperatures that you can select from by changing the dipswitch settings on the computer board.
- The temperature has been preset at the factory to 122°F (50°C).
- If you desire to change the set temperature with dipswitches, please refer to the diagram on below. These temperatures are available: 104°F, 113°F, 122°F, 131°F, 140°F, 158°F, 176°F, and 185°F.
- 140°F, 158°F, 176°F and 185°F are for heating applications only.
- If you desire a hot water temperature other than the 8 preset settings, please purchase the optional temperature remote controller (part No. TM-RE30).
- With this optional TM-RE30 you can set the temperature from 99°F to 176°F with various increments.
- Please read the instructions carefully prior to installing the TM-RE30, as failure to do so could damage the temperature controller and/or the water heater, which will void the warranty.



- Turn off the power supply to the heater before changing the dipswitch settings.
- Only change the switches with the dark squares. The dark squares indicate which direction the dipswitch should be set to.
- DO NOT set to 185 °F if you use your T-K3/T-K3-Pro in a recirculation system. This will cause damage to the heater and void the warranty.

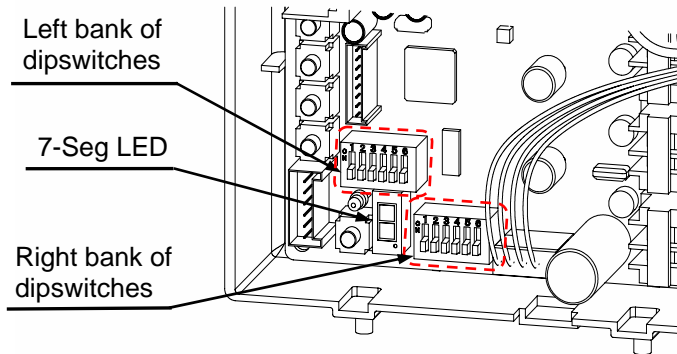

To change dipswitch settings for temperatures, locate the right bank of dipswitches the above of 7-seg LED. DO NOT adjust the left bank of dipswitches.

The dark squares indicate the direction the dipswitches should be set to.

## Temperature Settings <Right bank of dipswitches>

<p><b>104°F</b></p>	<p><b>113°F</b></p>	<p><b>122°F</b></p> <p>*Factory default setting</p>	<p><b>131°F</b></p>
<p><b>140°F</b></p>	<p><b>158°F</b></p>	<p><b>176°F</b></p>	<p><b>185°F</b></p>

## MAINTENANCE AND SERVICE



**WARNING:** Turn off the electrical power supply and close the manual gas control valve and the manual water control valve before servicing.

- Clean the cold-water inlet filter. (Refer to diagram below)
- Be sure that all openings for combustion and ventilation air are not blocked.
- Check that the exhaust vent pipe is not blocked.
- Check the gas pressure.
- Keep the area around the water heater clear. Remove any combustible materials, gasoline or any flammable vapors and liquids.

TAKAGI recommends having the unit checked once a year or as necessary by a licensed technician. If repairs are needed, any repairs should be done by a licensed technician.

### UNIT DRAINING and FILTER CLEANING

1. Close the manual gas shut off valve.
2. Turn off power to the unit, and then turn on again.
3. Wait 30 seconds, and then turn off power to the unit, yet again.
4. Close the water shut off valve.
5. Open all hot water taps in the house. When the residual water flow has ceased, close all hot water taps.
6. Have a bucket or pan to catch the water from the unit's drain plugs. **Unscrew** the drain plugs to drain all the water out of the unit.
7. Wait a few minutes to ensure all water has completely drained from unit.
8. **Clean the filter:** Check the water filter located within the cold inlet. With a tiny brush, clean the water filter of any debris which may have accumulated and reinsert the filter back into the cold water inlet.
9. Securely screw the drain plugs back into place. **Hand-tighten only.**

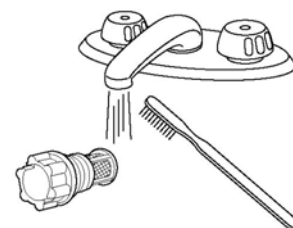
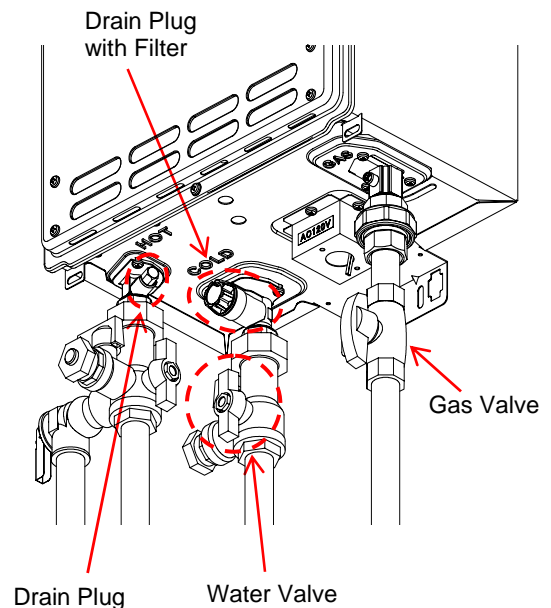

# **GENERAL TROUBLESHOOTING**

<b>~ TEMPERATURE and AMOUNT OF HOT WATER ~</b>	
<b>PROBLEM</b>	<b>POSSIBLE SOLUTIONS</b>
It takes long time to get hot water at the fixtures.	<ul style="list-style-type: none"> <li>• The time it takes to deliver hot water from the T-K3/T-K3-Pro to your fixtures depends on the length of piping between the two. The longer the distance or the bigger the pipes, the longer it will take to get hot water.</li> <li>• If you would like to receive hot water to your fixtures quicker, you may want to consider a hot water recirculation system. (p. 38)</li> </ul>
The water is not hot enough.	<ul style="list-style-type: none"> <li>• Compare the flow and temperature. See the chart on p. 46.</li> <li>• Check cross plumbing between cold water lines and hot water lines.</li> <li>• Is the gas supply valve fully open? (p. 27)</li> <li>• Is the gas line sized properly? (p. 18)</li> <li>• Is the gas supply pressure enough? (p. 17)</li> <li>• Is the set temperature set too low? (p. 28, 30)</li> </ul>
The water is too hot.	<ul style="list-style-type: none"> <li>• Is the set temperature set too high? (p. 28, 30)</li> </ul>
The hot water is not available when a fixture is opened.	<ul style="list-style-type: none"> <li>• Make sure the unit gets 120V 60Hz power supply.</li> <li>• If you are using the remote controller, is the power button turned on? (p. 28)</li> <li>• Is the gas supply valve fully open? (p. 27)</li> <li>• Is the water supply valve fully open? (p. 27)</li> <li>• Is the filter on cold water inlet clean? (p. 31)</li> <li>• Is the hot water fixture sufficiently open to draw at least 0.5 GPM through the water heater? (p. 28)</li> <li>• Is the unit frozen?</li> <li>• Is there enough gas in the tank? (for LP)</li> </ul>
The hot water turns cold and stays cold.	<ul style="list-style-type: none"> <li>• Is the flow rate enough to keep the T-K3/T-K3-Pro running? (p. 28)</li> <li>• If there is a recirculation system installed, does the recirculation line have enough check valves?</li> <li>• Is the gas supply valve fully open? (p. 27)</li> <li>• Is the filter on cold water inlet clean? (p. 31)</li> <li>• Are the fixtures clean of debris and obstructions?</li> </ul>
Fluctuation in hot water temperature.	<ul style="list-style-type: none"> <li>• Is the filter on cold water inlet clean? (p. 31)</li> <li>• Is the gas line sized properly? (p. 18)</li> <li>• Is the supply gas pressure enough? (p. 17)</li> <li>• Check for cross connection between cold water lines and hot water lines.</li> </ul>



## ~ WATER HEATER ~

PROBLEM	POSSIBLE SOLUTIONS
Unit does not ignite when water goes through the unit.	<ul style="list-style-type: none"> <li>• Is the flow rate over 0.5 GPM? (p. 28)</li> <li>• Check for the filter on cold water inlet. (p. 31)</li> <li>• Check for reverse connection and cross connection.</li> <li>• If you use the remote controller, is the power button turned on? (p. 28)</li> </ul>
The fan motor is still spinning after operation has stopped.	<ul style="list-style-type: none"> <li>• This is normal. After operation has stopped, the fan motor keeps running from 5 to 50 seconds in order to re-ignite quickly, as well as purge all the exhaust gas out of the flue.</li> </ul>
Abnormal sounds come from the unit.	<ul style="list-style-type: none"> <li>• Contact TAKAGI.</li> </ul>

## ~ REMOTE CONTROLLER: TM-RE30 (OPTIONAL) ~

PROBLEM	POSSIBLE SOLUTIONS
Remote controller does not display anything when the power button is turned on.	<p>Press the ON/OFF button.</p> <p>If the lamp lights up ⇒</p> <ul style="list-style-type: none"> <li>• This is normal. When the unit has not operated for five minutes or more, the display turns off to conserve energy.</li> </ul> <p>If the lamp does not light ⇒</p> <ul style="list-style-type: none"> <li>• Make sure the unit has power supply.</li> <li>• Make sure the connection to the unit is correct.(p. 22)</li> </ul>
An ERROR code is displayed.	<ul style="list-style-type: none"> <li>• Please see p. 34.</li> </ul>

## ~ EASY LINK SYSTEM ~

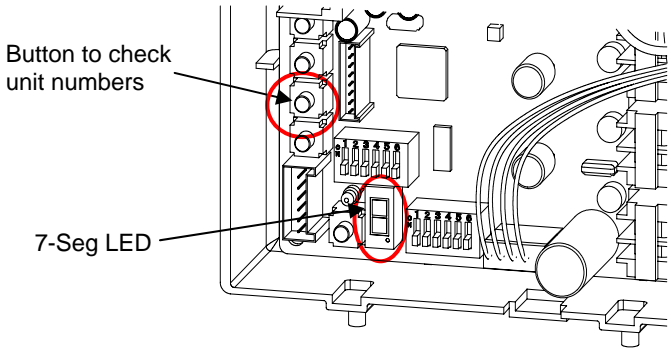
PROBLEM	POSSIBLE SOLUTIONS
How are the unit numbers assigned?	<ul style="list-style-type: none"> <li>• For an Easy Link system, other than the Master Unit (which is always labeled #1), all the other units (the Slave units) are numbered randomly.</li> <li>• To check which numbers are assigned to which Slave units, push the button on the computer board of a unit as shown below. The unit number will be displayed on the 7-Seg LED.</li> </ul> <div style="text-align: right;">  </div>

# TROUBLESHOOTING – ERROR CODES

- All Takagi units are self diagnostic for safety and convenience when trouble shooting.
- If there is a problem with the installation or the unit, it will display a numerical error code on the TM-RE30 (if installed) or on the 7-Seg LED at the bottom left corner of the computer board to communicate the source of the problem.
- Consult the following chart for the cause of each error code.

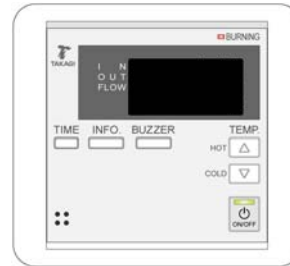
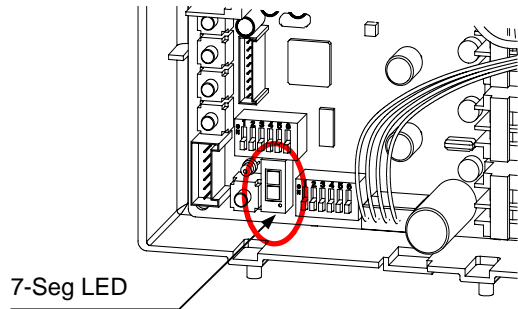

TM-RE30 (Optional)

Error Code	Malfunction description	Error Code	Malfunction description	Error Code	Malfunction description
031	Dipswitch setting fault	331	Mixing Thermistor Failure	701	Computer board Fault
101	Warning for 991 Error Code	391	Air-fuel Ratio Rod Failure	721	False Flame Detection
111	Ignition Failure	441	Flow Sensor Failure	741	Miscommunication between T-K3/T-K3-Pro and TM-RE30
121	Flame blows out	510	Abnormal Main and Solenoid Gas Valve	761	Miscommunication in Easy-link
311	Output Thermistor Failure	611	Fan Motor Fault	991	Abnormal burning
321	Inlet Thermistor Failure	651	Flow Adjustment Valve Fault		

## Single Unit

- The 7-Seg LED displays the 3-digit error codes one digit at a time. The TM-RE30 (if installed) displays the whole 3-digit error code at once.

### Example:

If your unit has the “321” error code (inlet thermistor),

- The 7-Seg LED, will flash the 3-digit error code one digit at a time. The 7-Seg LED will display “3”... “2”... “1”, and then repeat the 3 digits.
- The remote controller, however, will display “321” on its screen, in its entirety.

## Easy Link system

- The 7-Seg LED on the Master unit displays a 5-digit number to signify which unit in the Easy Link System has the error, and what the error code is. The 7-Seg LED displays the number one digit at a time.
- The TM-RE30 (if installed) displays a 3-digit number which also signifies which unit has the error, and what the error code is.
- The unit that has the error in an Easy Link System will display the error code on its 7-Seg LED in exactly the same way as if it were only a Single Unit.

### Example:

If Unit #2 has the “321” error code (inlet thermistor),

- The 7-Seg LED on the Master unit will display “3”... “2”... “1”... “0”... “2”, displaying only one digit at a time. The first 3 numbers indicate the error code. The last two numbers indicate that Unit #2 has the error.
- The remote controller, however, will display “232” on its screen in its entirety. The first “2” indicates that Unit #2 has the error. The “32” indicates the first two digits of the “321” error code.
- The 7-Seg LED on Unit #2 will display “3”... “2”... “1”, just like in the Single Unit example.

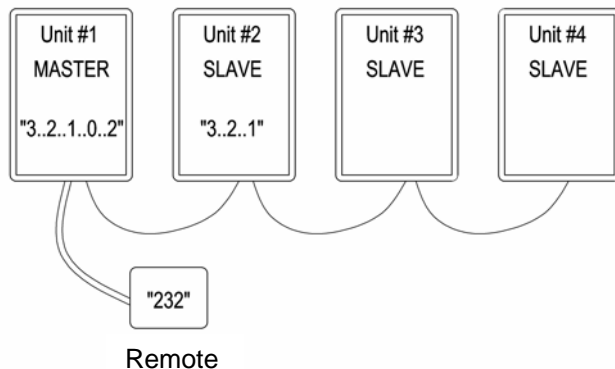

# WIRING DIAGRAM

A wiring diagram is located on the inside front panel of the appliance.

Electrical Rating: 120 VAC, 60 Hz

**Note:** If any of the original wiring supplied with this appliance must be replaced, it must be replaced with appliance wiring material (180c) or its equivalent. Replacement wires are available through Takagi.

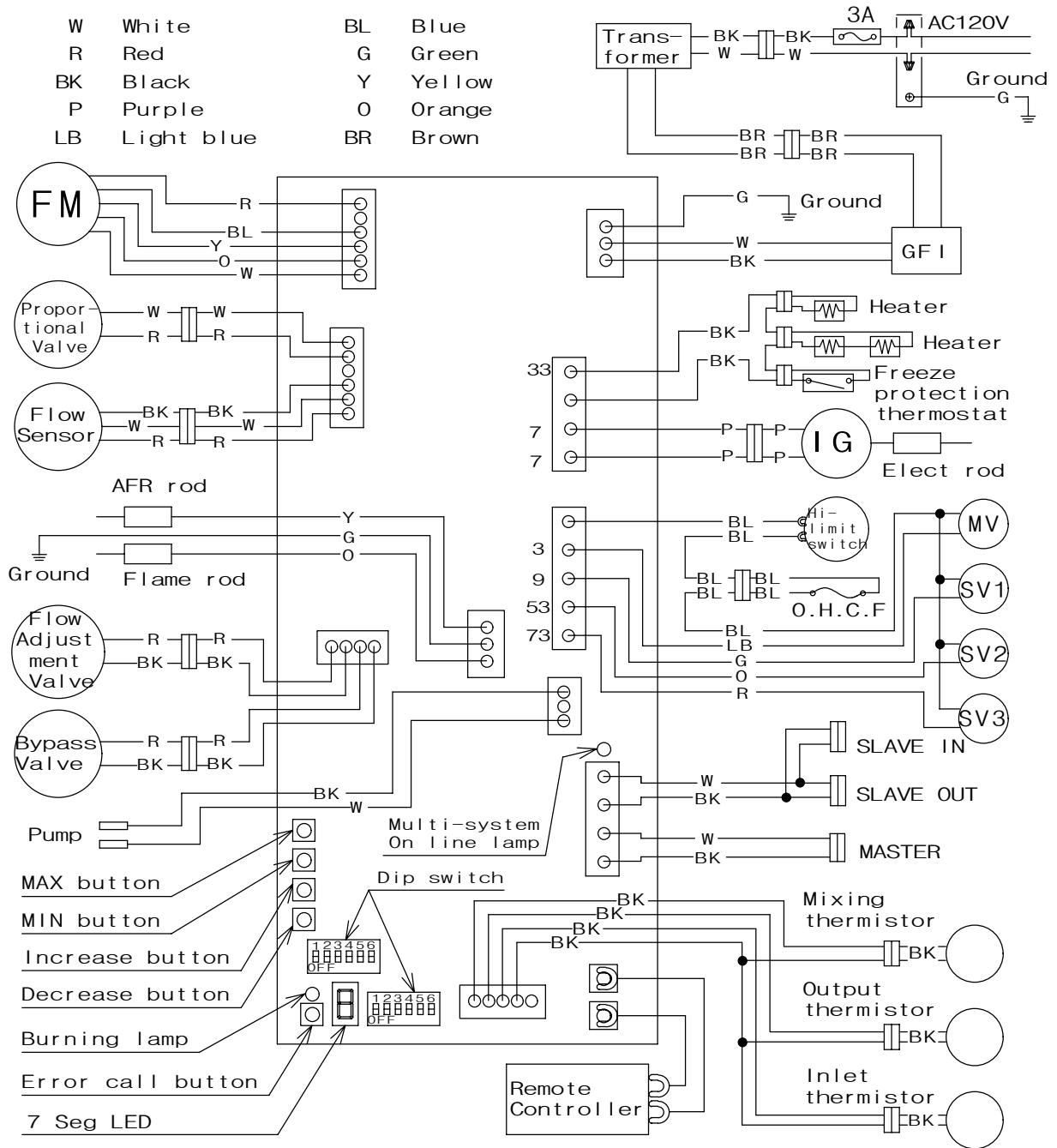

# OPERATING SAFETY

## FOR YOUR SAFETY READ BEFORE OPERATING

**WARNING:** If you do not follow these instructions exactly, a fire or explosion may result causing property damage, personal injury or loss of life.

- A. This water heater does not have a pilot. It is equipped with an ignition device that automatically lights the burner. Do not try to light the burner by hand.
- B. **BEFORE OPERATING** smell all around the water heater area for evidence of leaking gas. Be sure to smell next to the floor because some gas is heavier than air and will settle on the floor.

### WHAT TO DO IF YOU SMELL GAS.

- Do not try to light any appliance.
  - Do not touch any electric switch, do not use any phone in your building.
  - Immediately call your gas supplier from a neighbor's phone. Follow the gas supplier's instructions.
  - If you cannot reach your gas supplier, call the fire department.
- C. Use only your hand to turn the gas valve knob. Never use tools. If the knob will not turn by hand, don't try to repair it. Call a qualified service technician. Forced or attempted repair may result in a fire or explosion.
  - D. Do not use this water heater if any part has been under water. Immediately call a qualified service technician to inspect the water heater and to replace any damaged parts.

## OPERATING INSTRUCTIONS

1. **STOP!** Read the safety information above or in the Owners Manual.
2. Turn off all electric power to the water heater.
3. Do not attempt to light the burner by hand.
4. Turn the manual gas valve located on the outside of the unit clockwise ↻ to the off position.
5. Wait five (5) minutes to clear out any gas. If you then smell gas. **STOP!** Follow "B" in the safety information above on this label. If you don't smell gas, go to next step.
6. Turn the manual gas valve located on the outside of the unit counter clockwise ↻ to the ON position.
7. Turn on all electrical power to the water heater.
8. If the water heater will not operate, follow the instructions "to Turn Off Gas to water heater" and Call your service technician or gas supplier.

## TO TURN OFF GAS TO APPLIANCE

1. Turn off all electric power to the water heater if service is to be performed.
2. Turn the manual gas valve located on the outside of the unit clockwise ↻ to the off position.

## DANGER



**Vapors from flammable liquids will explode and catch fire causing death or severe burns.**

Do not use or store flammable products such as gasoline, solvents or adhesives in the same room or area near the water heater.

Keep flammable products:

1. Far away from heater.
2. In approved containers.
3. Tightly closed
4. Out of children's reach

Vapors:

1. Cannot be seen
2. Vapors are heavier than air
3. Go a long way on the floor
4. Can be carried from other rooms to the main burner by air currents

**WARNING: Do not install water heater where flammable products will be stored.**

**Read and follow water heater warnings and instructions. If owner's manual is missing, contact the retailer or manufacturer.**

## WARNING

The outlet hot water temperature of the T-K3/T-K3-Pro water heater is factory set at 122 °F. Use this heater at your own risk. The set outlet water temperature can cause severe burns instantly or death from scalds. Test the water before bathing or showering. Do not leave children or an infirm person in the bath unsupervised.

## DANGER



Hot Water Heater temperature over 125 °F can cause severe burns instantly or death from scalding. Children, disabled and elderly are at the highest risk of being scalded. Feel water temperature before bathing or showering. Temperature limiting valves are available. Ask a professional person.

**WARNING:** California Proposition 65 lists chemical substances known to the state to cause cancer, birth defects, death, serious illness or other reproductive harm. This product may contain such substances, be their origin from fuel combustion (gas, oil) or components of the product itself.

# APPLICATIONS

## Space Heating Applications

- Toxic chemicals used in boiler treatments such as alcohol, glycerol and glycol group must not be introduced into the system when used for open loop potable water and space heating.
- The T-K3/T-K3-Pro can be used to supply potable water and space heating and shall not be connected to any heating system or component(s) previously used with non-potable water where any chemicals were added to the water heating appliances.
- When the system requires water for space heating at temperatures higher than required for other uses, a means such as a mixing valve shall be installed to temper the water for those other uses in order to reduce scald hazard potential.
- Water temperature over 125 °F can cause severe burns instantly or death from scalds.
- Chemicals such as diluted Glycol can be used for radiant floor, Hydro/fan coil air or Baseboard heating only. The diluted solution of glycol must contain LESS than 30% of Glycol. Be aware that in closed-loop glycol systems, low pressure in the heat exchanger can cause low-temperature boiling, resulting in excessive noise and damage to the water heater. Consult with the glycol maker for specifications prior to use.

### Re-circulation:

\* Size the pump to provide at about 2 GPM through the system at 15 Ft of Head plus applications and piping head losses. 2 GPM will allow the system to operate at its optimal performance.

\* If the application requires a higher re-circulating flow rate, make sure that the re-circulating flow rate is **no greater than 4 GPM**. If the flow rate is too high, the system could be damaged by erosion

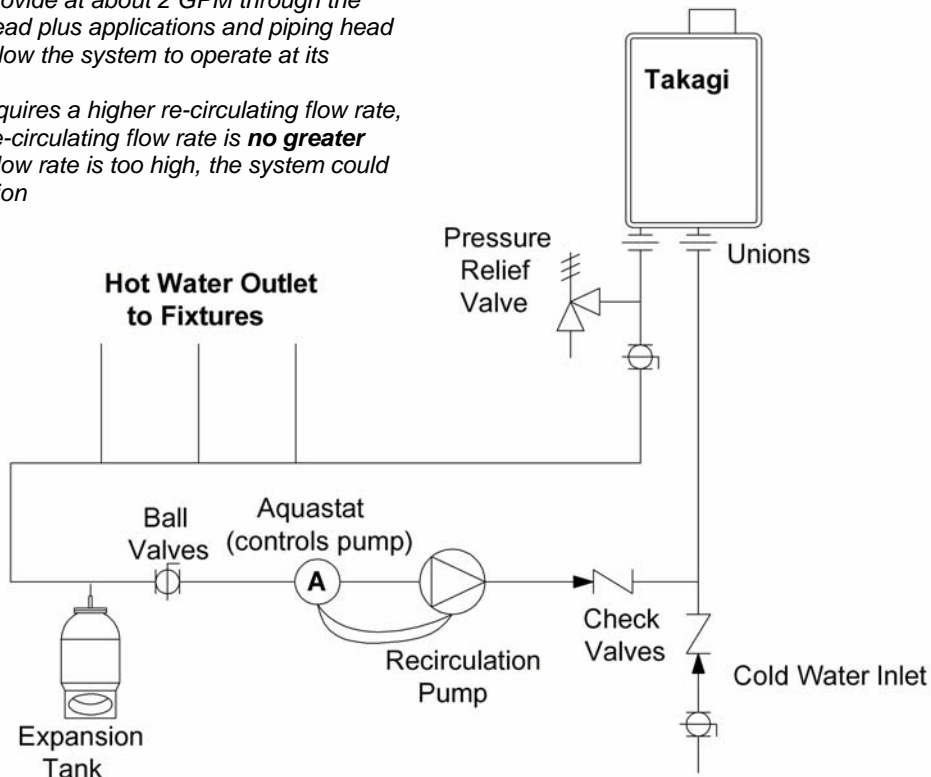

This is a concept drawing only.

## Dual-purpose hot water heating (Domestic and Space Heating):

### Diagrammatic Layout of Radiant Heating and Domestic Water Heater Per Mass. Code

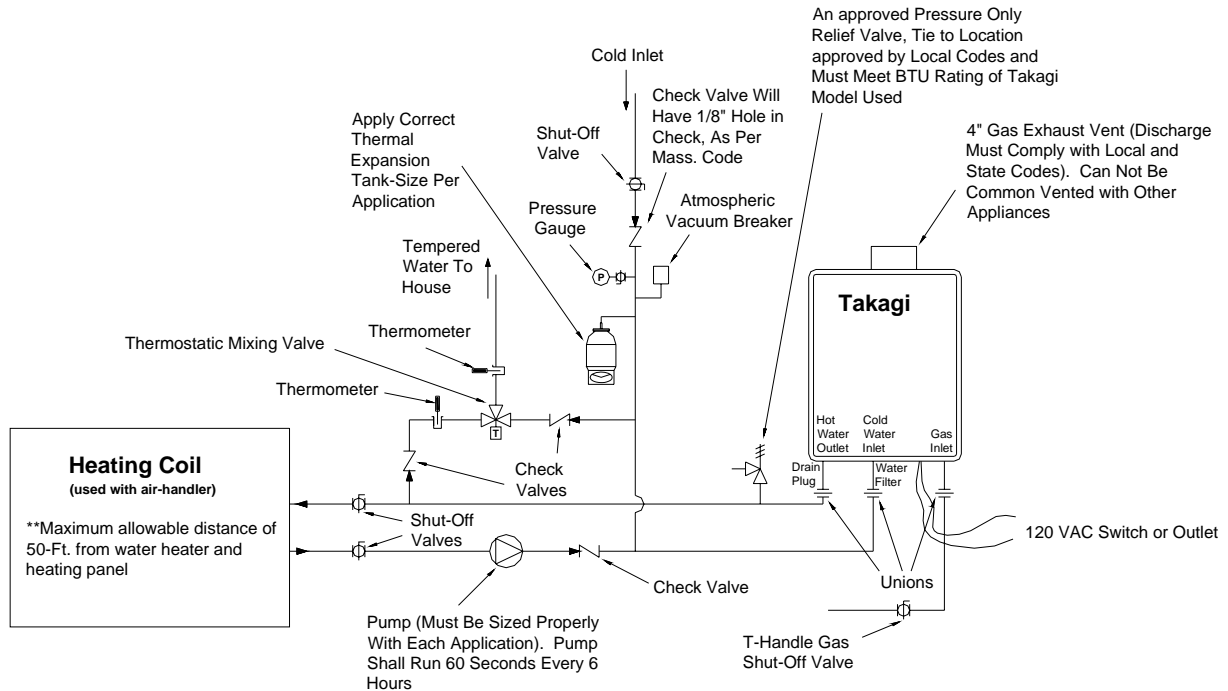

- \* Size the pump to provide at about 2 GPM through the system at 15 Ft of Head plus applications and piping head losses. 2 GPM will allow the system to operate at its optimal performance.
- \* If the application requires a higher re-circulating flow rate, make sure that the re-circulating flow rate is **no greater than 4 GPM**. If the flow rate is too high, the system could be damaged by erosion.

**Priority Control Devices** such as a flow switch, an Aquastat or other electronic controller can be used to prioritize the domestic water system over the heating system.

**Warning:** Follow all local codes, or in the absence of local codes, follow the most recent edition of the National Standard Code, ANSI Z21. 10.3.

**Warning:** This illustration is a concept design only. The reference to the 1/8<sup>th</sup> hole in check is only for the State of Massachusetts. There are a wide variety of variations to the application of controls and equipment presented. Designers must add all necessary safety and auxiliary equipment to conform to code requirements and design practice. For more details, contact the Takagi Technical Department at (888) 882-5244

# OPTIONAL ITEMS

## 1. TM-RE30 Temperature Remote Controller



The TM-RE30 Temperature Remote Controller has two functions. It allows the output temperature from the T-K3/T-K3-Pro to be adjusted within the range of 99 °F to 185 °F, and it also works as a diagnostic tool that will give a concise error code whenever there is a problem with the unit. The temperature options are 99°F, 100°F, 102°F, 104°F, 106°F, 108°F, 110°F, 111°F, 113°F, 115°F, 117°F, 122°F, 131°F, 140°F, 149°F, 158°F, 167°F, 176°F and 185°F. See the trouble shooting section for information on possible error codes.

## 2. TK-BF01 Backflow preventer



The TK-BF01 Backflow preventer prevents the backflow of air through the exhaust vent. This helps prevent harmful exhaust gases from entering the home, as well as helping to prevent the unit from freezing in areas where cold air can be blown or drawn into the exhaust system. Install this vent damper in accordance with Takagi's installation instructions, and any applicable codes.

## 3. TK-TV04 Vent Cap



The TK-TV04 Vent Cap is for outdoor installation with the T-K3/T-K3-Pro water heater. The cap is installed on the top of the unit, instead of connecting an exhaust vent pipe. The cap will prevent any debris that might be in the environment from entering the unit and causing damage or a fire hazard, as well as preventing rain or other weather from entering the unit.

## 4. TK-TV10 Direct venting kit



This kit can be used to convert the T-K3/T-K3-Pro from a conventional vent system to a direct vent (or sealed combustion) system. This is a CSA tested Takagi conversion kit. Install this conversion kit in accordance with Takagi's installation instructions and any applicable codes.

## 5. TK-PC01 Pipe cover



The TK-PC01 Pipe cover protects the plumbing pipes to the T-K3/T-K3-Pro from unexpected adjustments. This pipe cover is fixed to the bottom of the T-K3/T-K3-Pro, which hides the plumbing and improves the visual aspects of the whole installation for the water heater.

## 6. TK-RB01 Recess box



The TK-RB01 will allow for "clean" installations. The T-K3/T-K3-Pro fits inside the recess box, which hides and protects the whole water heater and plumbing. The TK-RB01 fits between most wall studs.

## 7. TK-KPWL4 and TK-KPWH4 T-Vent Wall thimble with Termination



**TK-KPWL4**  
**Louver**  
**Termination**



**TK-KPWH4**  
**Hood**  
**Termination**

These terminations are used when venting out through the wall and are compatible with the T-Vent pipe system.

These terminations are special stainless steel vents for gas appliances and are UL listed as Category II, III and IV. There are two types of terminations: the Louver termination and the Hood termination. For different wall thicknesses, there are 3 ranges of lengths available (refer to the T-Vent brochure for details). Install these vent terminations in accordance with Takagi's installation instructions and any applicable local codes.



# COMPONENTS DIAGRAM

## Case assembly

Other than the front cover (No.7), all of the T-K3-Pro's parts are the same as the T-K3.

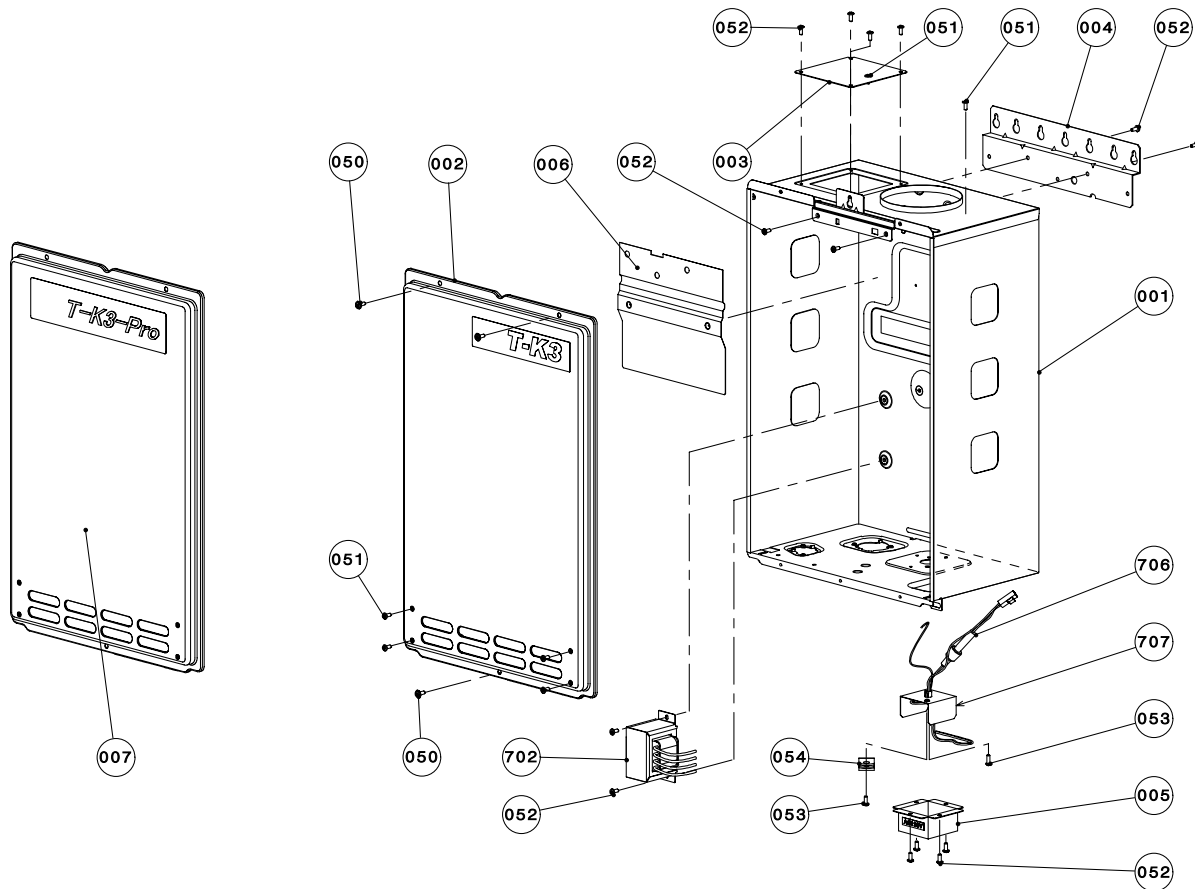

## Computer board assembly

The T-K3 and the T-K3-Pro share the same components.

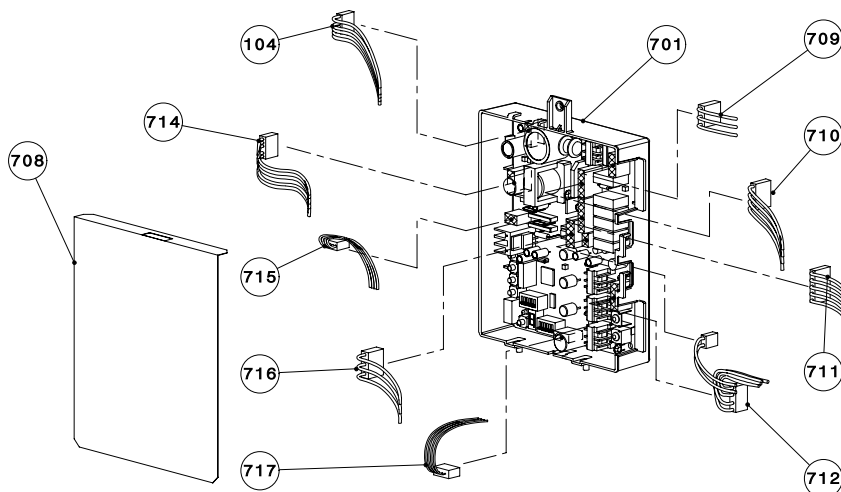

# Burner assembly

The T-K3 and the T-K3-Pro share the same components.

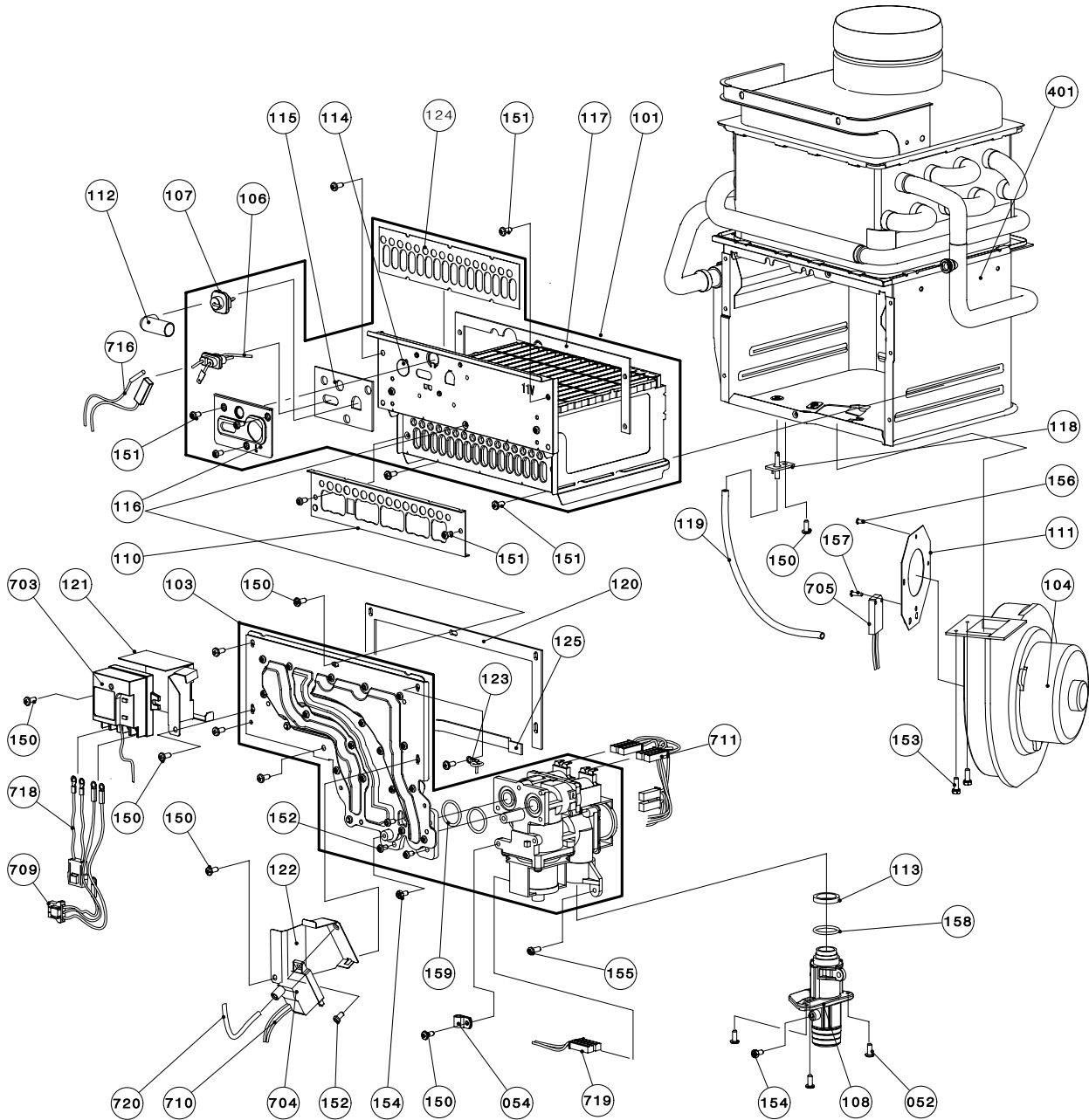

# Water way assembly

Other than the heat exchanger assembly (No.420), all of the T-K3-Pro's parts are the same as the T-K3.

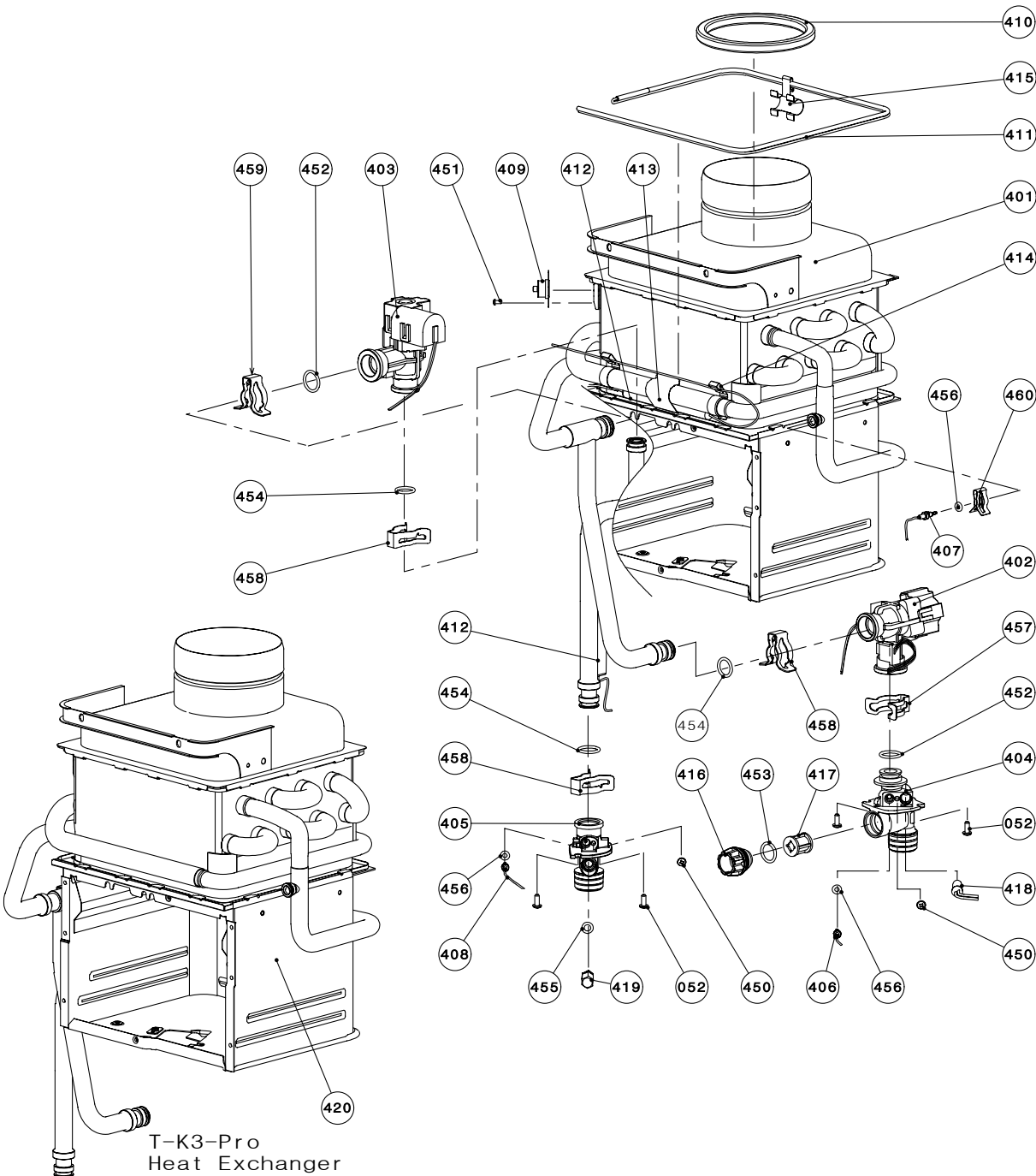

# PARTS LIST

Other than the front cover (No.7) and heat exchanger assembly (No.420), all of the T-K3-Pro's components are the same as the T-K3.

Item#	Part#	Description	Item#	Part#	Description
1	EKK1D	Case assembly	122	EKK1B	Igniter plate
2	EKK1J	Front cover for T-K3	123	EM167	Wire clamp 60
3	EKJ62	Air blockage plate	124	EKK2X	Burner gasket
4	EKJ09	Bracket	125	EKK2K	Manifold gasket B
5	EKJ64	Junction box	150	EW003	Screw M4x10
6	EKK5H	Back guard panel	151	EW002	Screw M4x10 (Coated)
7	EK320	Front cover for T-K3-Pro	152	EKK37	Screw M4x12
50	EW000	Screw M4x12	153	EW004	Hex head screw M4x12
51	EW001	Screw M4x10 (W/Washer)	154	EW005	Hex head screw M4x8
52	EW002	Screw M4x10 (Coated)	155	EW006	Pan screw M4x10
53	EW003	Screw M4x10	156	EW00B	Screw M3x8
54	EC00X	Nylon clamp	157	EW008	Screw M3x10
101	EKK1N	Burner assembly	158	EK042	O-ring P20 NBR
103	EKK1S	Manifold assembly with gas valve assembly LP	159	EZP18	O-ring P18 NBR
	EKK1T	Manifold assembly with gas valve assembly NA	401	EKK1X	Heat exchanger assembly for T-K3
104	EKK25	Fan motor	402	EKK0T	Flow adjustment valve/ Flow sensor
106	EKK0E	Flame rod	403	EKK0U	Bypass valve
107	EKK0F	Igniter rod	404	EKK1U	Water inlet
108	EKK1E	Gas inlet	405	EKK1V	Water outlet
110	EKK1P	Damper	406	EKK38	Inlet thermistor
111	EK270	Fan damper	407	EKK2T	Output thermistor
112	EKN61	Rod cap	408	EKK1A	Mixing thermistor
113	EKK2Z	Gas inlet ring	409	EKN34	Hi-Limit switch
114	EKK2V	Burner window	410	EKN50	Silicon ring
115	EKK2W	Rod holder gasket	411	EK333	Over heat cut off fuse
116	EKK32	Rod holder	412	EKK2R	Heater
117	EKK0G	Burner holder gasket	413	EKK27	Pipe heater fixing plate
118	EKK2D	Pressure port	414	EKK26	Fuse fixing plate 18
119	EKK2N	Urethane tube	415	EK029	Fuse fixing plate 14
120	EKK2Y	Manifold gasket A	416	EKK2B	Inlet drain plug
121	EKK20	GFI plate	417	EKK2C	Inlet water filter

Item#	Part#	Description	Item#	Part#	Description
418	EKK2P	Inlet heater	705	EKJ59	Freeze protection thermostat
419	EKK2E	Outlet drain plug	706	EKN37	Fuse assembly
420	EK322	Heat exchanger assembly for T-K3-Pro	707	EKJ66	Junction box inner plate
450	EW009	Screw M4x6	708	EKK1M	Computer board cover
451	EW00A	Screw M4x3	709	EKK0D	AC100V wire
452	EZM16	O-ring P16 FKM	710	EKK0Z	EH-IG Wire
453	EZM15	O-ring P15 FKM	711	EKK10	Gas valve wire
454	EZM14	O-ring P14 FKM	712	EKK36	Pump and multi cable
455	EZM06	O-ring P6 FKM	714	EKK35	RS-VG wire
456	EZM04	O-ring P4 FKM	715	EKK33	Water valves wire
457	EM192	Fastener "16A"	716	EKK11	Flame rod wire
458	EKK24	Fastener "14-22"	717	EKK1Z	Thermistors wire
459	EKK39	Fastener "16-25A"	718	EKK0B	Transformer wire
460	EKH30	Fastener "4-11"	719	EKK12	Proportional gas valve wire
701	EKK1L	Computer board	720	EKK2M	High voltage igniter wire
702	EKH09	Transformer			
703	EKN73	Ground fault circuit interrupter			
704	EKN74	Igniter			

# OUTPUT TEMPERATURE CHART

Out Put Temperature vs. GPM (Max.7.0 GPM) with Various Ground Water Temperature  
 Correct Gas pipe size can be expect this chart

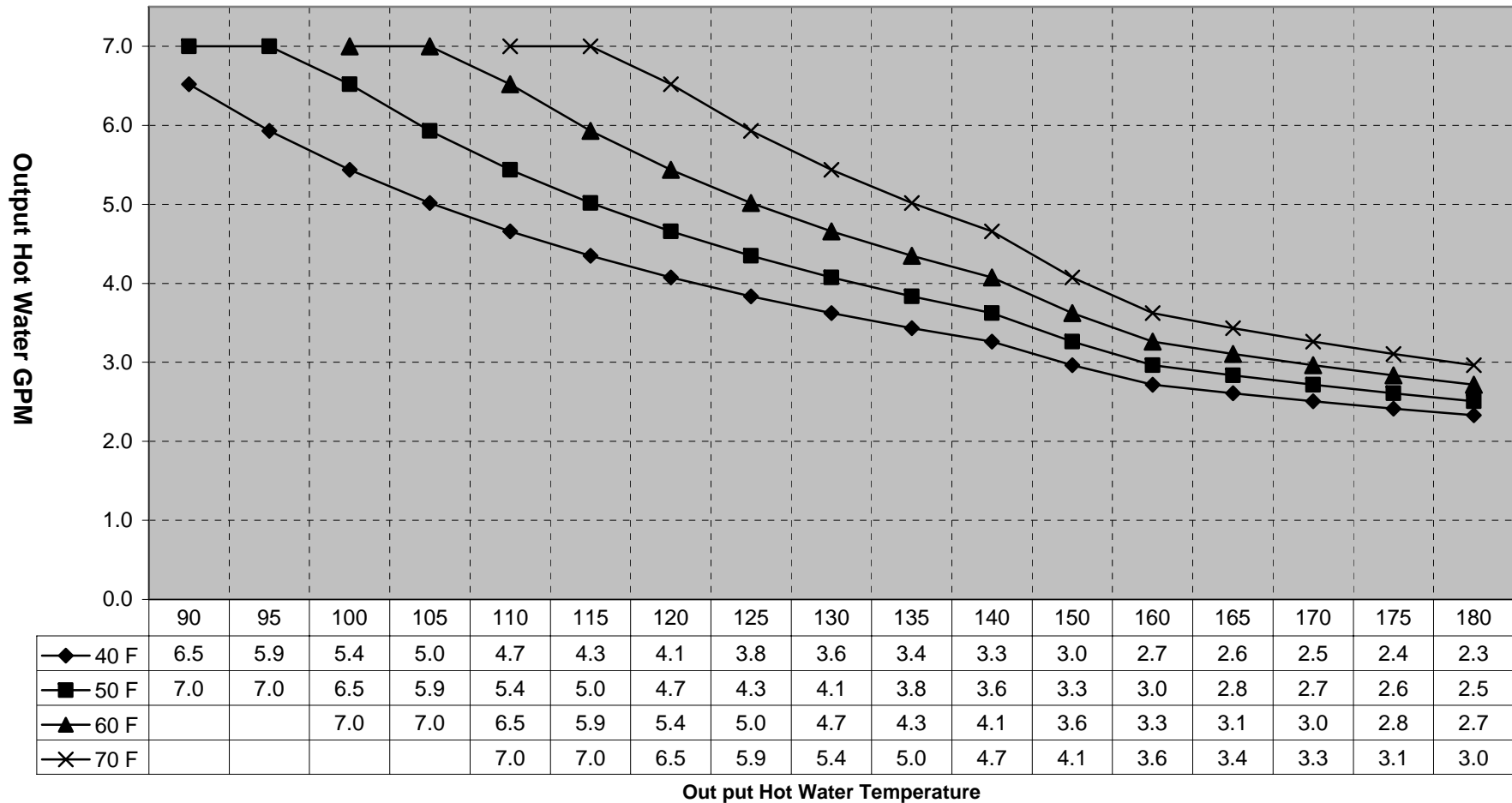

◆ 40 F ■ 50 F ▲ 60 F ✕ 70 F

\*When the set temperature is 158°F or higher, maximum flow rate is limited to 5.4 GPM.

# PRODUCT REGISTRATION AND LIMITED WARRANTY

1. Product registration card or form:

The enclosed product registration card must be completed and returned within 45 days of original purchasing date by retail buyer. Copy of proof of original purchasing date must be sent in with the warranty card. The customer may register online with attached proof of original purchasing date via the Internet ([www.takagi.com/warranty](http://www.takagi.com/warranty)). **THE CARD OR FORM IS FOR PRODUCT REGISTRATION. FAILURE TO COMPLETE AND RETURN THE CARD OR FORM DOES NOT DIMINISH YOUR WARRANTY RIGHTS.**

2. General terms of limited warranty:

This limited warranty gives you specific legal rights, and you may also have other rights which vary from State to State. The manufacturer, Takagi Industrial Co. USA, Inc., will honor the warranty to the original retail buyer at the original location only, and it is not transferable. **THIS WARRANTY COVERS ONLY FAILED MECHANICAL AND ELECTRICAL PARTS DUE TO FACTORY DEFECTS UNDER NORMAL USAGE FOR THE PRODUCT'S INTENDED PURPOSES AND WITHIN THE APPLICABLE PERIOD SPECIFIED IN THE FOLLOWING TABLES. ONLY DIRECT DAMAGES SHALL BE RECOVERABLE BY A CLAIMANT UNDER THIS LIMITED WARRANTY AND, IN NO EVENT, WHETHER AS A RESULT OF BREACH OF CONTRACT, BREACH OF WARRANTY, TORT LIABILITY (INCLUDING NEGLIGENCE), STRICT LIABILITY, INDEMNITY OR OTHERWISE WILL TAKAGI BE LIABLE FOR ANY SPECIAL, INCIDENTAL, OR INDIRECT CONSEQUENTIAL DAMAGES INCLUDING PROPERTY DAMAGE, PERSONAL DAMAGES, LOSS OF USE, OR INCONVENIENCE. SOME STATES DO NOT ALLOW THE EXCLUSION OR LIMITATION OF INCIDENTAL OR CONSEQUENTIAL DAMAGES, SO THE ABOVE LIMITATION MAY NOT APPLY TO YOU.**

3. Warranty for models: T-K3-Pro

Application		HX <sup>(1)</sup>	Parts	Labor
Single Family Domestic Hot Water	No Recirculation		10	1 <sup>(3)</sup>
	On-Demand Recirculation <sup>(2)</sup>			
	w/ Standard Recirculation	Aquastat Control	5	
		Takagi Pump Control		
		Timer Only		
No Pump Control (24 hr.)		3	3	
Commercial or Multi-Family Domestic Hot Water	No Recirculation		5	1 <sup>(3)</sup>
	On-Demand Recirculation <sup>(2)</sup>			
	w/ Standard Recirculation	Aquastat Control	5	
		Takagi Pump Control		
		Timer Only		
No Pump Control (24 hr.)		3	3	
Heating <sup>(4)</sup>	All Types	5	5	1 <sup>(3)</sup>

[Unit: Year]

Warranty for models: T-K3

Application		HX <sup>(1)</sup>	Parts	Labor
Single Family Domestic Hot Water	No Recirculation		10	1 <sup>(3)</sup>
	On-Demand Recirculation <sup>(2)</sup>			
	w/ Standard Recirculation	Aquastat Control	3	
		Takagi Pump Control		
		Timer Only		
No Pump Control (24 hr.)		1	1	
Multi-Family Domestic Hot Water	No Recirculation		3	1 <sup>(3)</sup>
	On-Demand Recirculation <sup>(2)</sup>			
	w/ Standard Recirculation	Aquastat Control	3	
		Takagi Pump Control		
		Timer Only		
No Pump Control (24 hr.)		1	1	
Heating <sup>(4)</sup>	All Types	1	1	1 <sup>(3)</sup>
Commercial	All Types	1	1	1 <sup>(3)</sup>

[Unit: Year]

- (1) Heat exchanger
- (2) An on-demand recirculation system is a system that utilizes either a push-button or other type of manual activation (as opposed to automatic activation with a temperature sensor or timer) to activate the circulation pump. An on-demand recirculation system can use either the existing cold water line as the return line or have its own dedicated return line.
- (3) Limited Labor Coverage
  - Takagi will provide for reasonable labor charges associated with warranty repairs or replacements within one (1) year from the date of purchase. Takagi will only pay directly to the service provider.
  - Warranty service must be performed by an authorized Takagi Service Representative. A list of authorized Takagi Service Representatives is available upon request.
  - All warranty claims and warranty service must be authorized and approved by Takagi.
- (4) Includes dual-purpose applications (combination heating and domestic).

4. Repair, Replacement or Refund:

The manufacturer or its authorized Service Representative will, at its sole discretion, repair or replace any failed or defective mechanical or electrical parts, or components thereof, or, if the manufacturer or its authorized Service Representative cannot replace said parts, and repair is not commercially practicable, the manufacturer or its authorized Service Representative will refund the purchase price. The manufacturer or its authorized Service Representative may, at its sole discretion, use new, refurbished or reconditioned parts.

5. Limitation on Duration of Implied Warranties:

**ANY IMPLIED WARRANTIES ARISING UNDER STATE LAW, INCLUDING THE IMPLIED WARRANTIES OF FITNESS FOR A PARTICULAR PURPOSE AND MERCHANTABILITY, SHALL IN NO EVENT EXTEND PAST THE EXPIRATION OF ANY WARRANTY PERIOD HEREUNDER. SOME STATES DO NOT ALLOW LIMITATIONS ON HOW LONG AN IMPLIED WARRANTY LASTS, SO THE ABOVE LIMITATION MAY NOT APPLY TO YOU.**

6. THIS WARRANTY WILL NOT COVER THE FOLLOWING:

- Any Takagi product that is not installed by a licensed plumber, gas installer, or contractor.
- Damages due to accidents, abuse, misuse, improper installation, misapplication, or incorrect sizing.
- Damages due to fires, flooding, freezing, electrical surges, or any Acts of God.
- Damages due to unauthorized alterations, attachments, and/or repairs.
- Damages due to a lack of maintenance (e.g. water filter, water treatment system, vent blockage, etc.)
- Any Takagi product installed in an improper environment (e.g. corrosive, dusty, chemically contaminated, excessive lint, etc.)
- Freeze damage that occurs without taking proper preventive measures as described in the installation manual
- Condensate damage due to improperly installed or lack of a condensate trap (drain).
- Any Takagi product not installed in compliance with all applicable local & state codes, ordinances, and good trade practices.
- Any Takagi product sold to or installed in areas outside of the fifty states (and the District of Columbia) of the United States of America and Canada.
- Any Takagi product installed in applications that cause the water heater to activate more than 300 times per day (this averages to an activation every 5 minutes in a 24-hour period).
- Any failures that are not due to defects in materials or workmanship (mechanical and/or electrical parts).
- Damages due to improper installation:
  - Gas: incorrect gas pipe sizing, incorrect gas meter sizing, incorrect gas type, and/or gas pressures that fall outside the product's specified range.
  - Water: incorrect water pipe sizing, water pressures that fall outside the product's specified range, recirculation flow rates that fall outside the product's specified range (air removal), and/or lack of proper methods of air removal in a closed-loop, circulation system (see installation manual for details).
  - Electric: supply power voltages that fall outside the product's specified range.
- Damages due to water quality:
  - Introduction of liquids other than potable water or potable water / glycol mixtures into the product.
  - Introduction of pool water, spa water, or any chemically treated water into the product
  - Introduction of hard water measuring more than 7 grains per gallon (120 ppm) for single family domestic applications or more than 4 grains per gallon (70 ppm) for all other types of applications into the product
  - Introduction of untreated or poorly treated well water into the product
  - Introduction of water with pH levels less than 6.5 and greater than 8.5 into the product.