

E. Components Diagram / Parts List

Case assembly

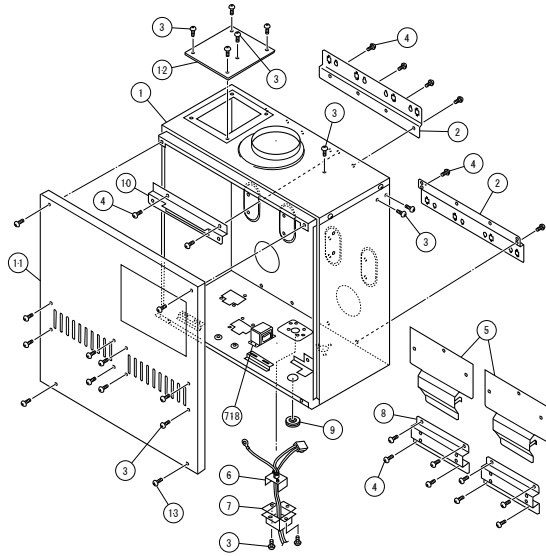

Item#	Part#		Description
	910 models	T-M50 models	
001	319143-265	EM305	Case assembly
002	319143-012	EM335	Brackets
003	319143-325	EW001	Screw M4x10 (W/Washer)
004	319143-026	EW002	Screw M4x10 (Coated)
005	319143-237	EM264	Back guard panel
006	319143-277	EM333	Power supply code assembly
007	319143-014	EKJ64	Junction box
008	319143-230	EM255	Chamber fixing plate
009	319143-334	EX00B	Rubber bush
010	319143-236	EM263	Exhaust fixing plate

Item#	Part#		Description
	910 models	T-M50 models	
011	319143-262	EM301	Front cover for 910 (T-M50)
012	319143-246	EM278	Air blockage plate
013	319143-025	EW000	Screw M4x12 (W/Washer)

Burner assembly

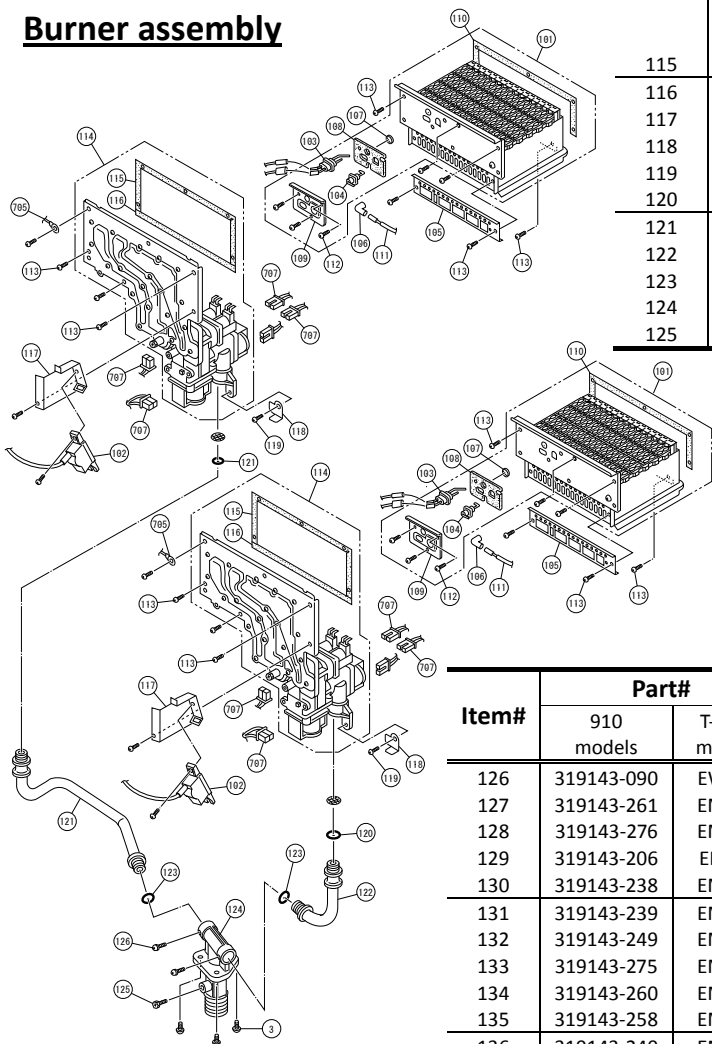

Item#	Part#		Description
	910 models	T-M50 models	
126	319143-090	EW00L	Pan screw M4x6 (W/Washer)
127	319143-261	EM300	Exhaust connector
128	319143-276	EM331	Exhaust combining box
129	319143-206	EKK3G	Silicon ring
130	319143-238	EM266	Exhaust gasket A
131	319143-239	EM267	Exhaust gasket B
132	319143-249	EM282	Case beam
133	319143-275	EM330	Exhaust auxiliary plate
134	319143-260	EM299	Duct
135	319143-258	EM294	Duct cover
136	319143-240	EM268	Duct gasket
137	319143-060	EW003	Screw M4x10
138	319143-147	EK270	Fan damper
139	319143-330	EW00B	Screw M3x6
140	319143-252	EM286	Freeze protection thermostat

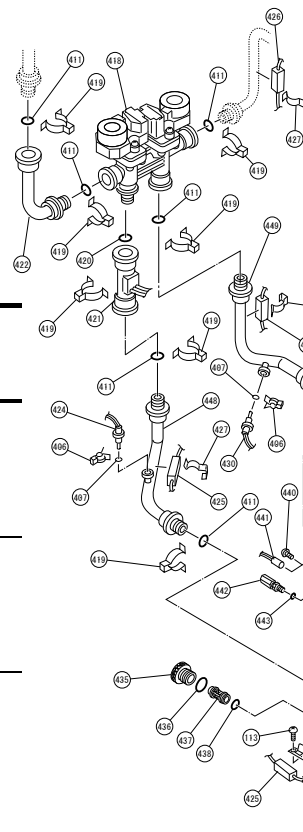

910 ASME (T-M50 ASME)

Item#	Part#		Description
	910 models	T-M50 models	
701	319143-266	EM306	Right and left computer board
702	319143-267	EM307	Central computer board
703	319143-232	EM258	PV-FS wire
704	319143-233	EM260	Thermistor connecting wire
705	319143-243	EM271	Flame rod wire
706	319143-231	EM257	Igniter wire
707	319143-248	EM280	Gas valve wire
708	319143-245	EM277	AC 100V wire
709	319143-183	EKH43	Right and left computer board cover
710	319143-274	EM329	Central computer board cover
711	319143-247	EM279	Multi communication wire
712	319143-234	EM261	Left communication wire
713	319143-235	EM262	Right communication wire
714	319143-244	EM273	Remote controller terminal
715	319143-048	EM167	Wire Cramp

Computer board assembly

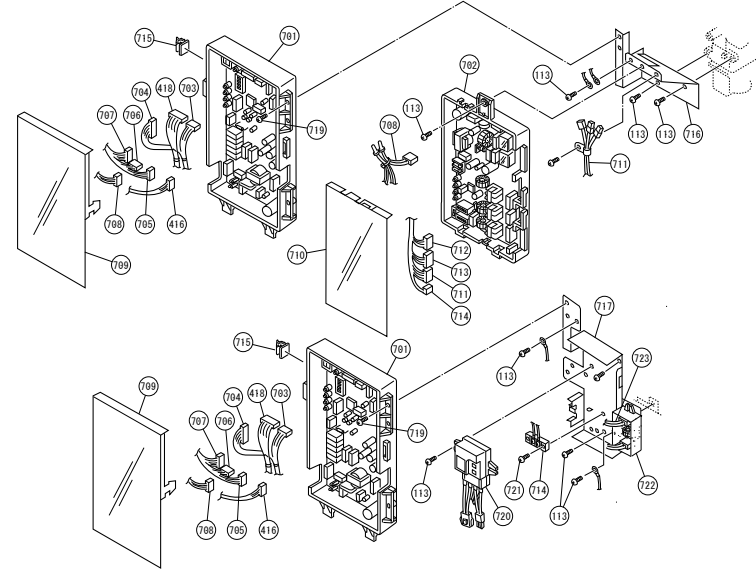

Item#	Part#		Description
	910 models	T-M50 models	
716	319143-241	EM269	Left PCB fixing plate
717	319143-242	EM270	Right PCB fixing plate
718	319143-127	EM296	Transformer
719	319143-343	EX013	Screw M4x12
720	319143-227	EM207	Ground fault circuit interrupter
721	319143-331	EW00X	Screw M3x12
722	319143-284	EM385	Surge box
723	319143-215	EKK4U	Surge connecting wire

Item#	Part#		Description
	910 models	T-M50 models	
401	319143-268	EM308	Heat exchanger assembly for 910 (T-M50)
402	319143-149	EK333	Overheat cut-off-fuse
403	319143-095	EKN34	Hi-Limit switch
404	319143-087	EW00A	Screw M3x6
405	319143-096	EKK2T	Output thermistor
406	319143-097	EKH30	Fastener "14-11"
407	319143-082	EZM04	O-ring P4 FKM
408	319143-224	EKN86	Pipe heater 122
409	319143-088	EKK27	Heater fixing plate
411	319143-083	EM16	O-ring P16 FKM
412	319143-061	EW00H	Pan screw M4x12 (W/Washer)
413	319143-229	EM252	Fan motor fixing plate
414	319143-042	EKK2D	Pressure port
415	319143-344	EX019	Urethane tube

Combustion and Exhaust assembly

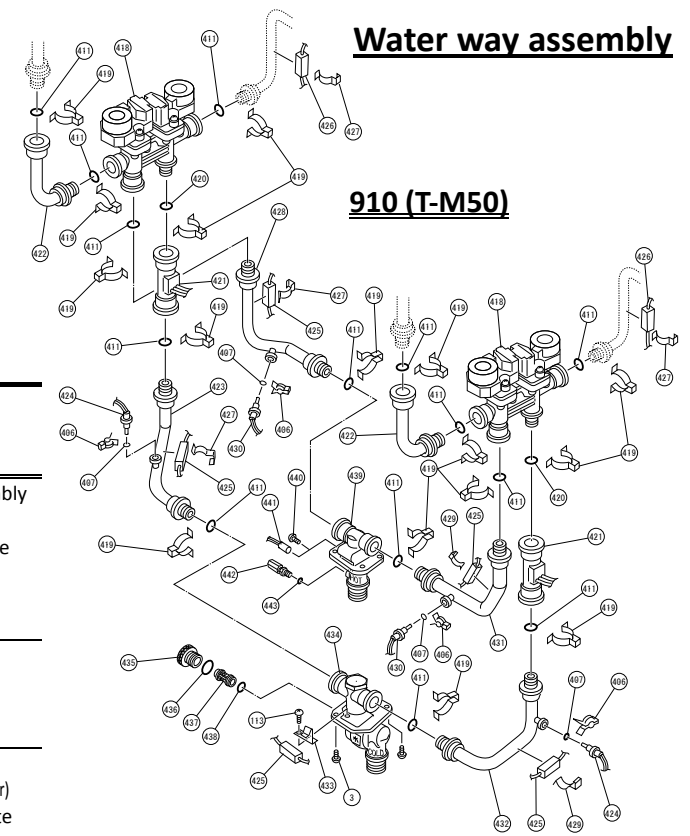
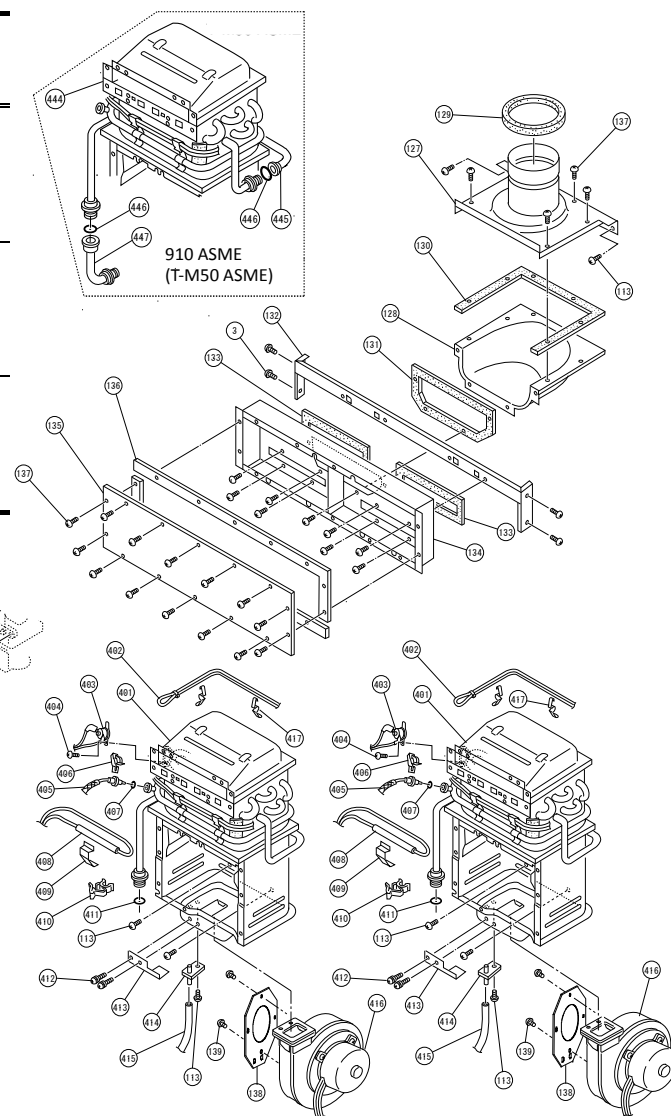

910 (T-M50)

Item#	Part#		Description
	910 models	T-M50 models	
416	319143-043	EKK25	Fan motor
417	319143-066	EKK26	Fuse fixing plate 18
418	319143-086	EKH32	Water control valve
419	319143-077	EX01H	Fastener "16AG"
420	319143-083	EZM16	O-ring P16 FKM
421	319143-092	EKH33	Flow sensor
422	319143-251	EM285	Connecting pipe
423	319143-254	EM290	Left cold pipe for 910 (T-M50)
424	319143-085	EKK38	Inlet thermistor
425	319143-333	EX001	Heater 502
426	319143-068	EX002	Heater 101
427	319143-125	EK031	Heater fixing plate 16
428	319143-273	EM328	Left hot pipe for 910 (T-M50)
429	319143-124	EKH38	Heater fixing plate 20
430	319143-190	EKK1A	Mixing thermistor
431	319143-256	EM292	Right hot pipe for 910 (T-M50)
432	319143-255	EM291	Right cold pipe for 910 (T-M50)
433	319143-076	EX021	Heater plate
434	319143-259	EM295	Water inlet
435	319143-070	EM222	Filter plug
436	319143-071	EAM25	O-ring P25 FKM
437	319143-072	EX006	Water inlet filter
438	319143-073	EZN21	O-ring JASO #1021 FKM
439	319143-269	EM309	Water outlet
440	319143-328	EW009	Screw M4x6
441	319143-223	EKN67	Heater 117
442	319143-199	EKK2E	Outlet drain plug
443	319143-080	EZM06	O-ring P6 FKM
444	319143-270	EM323	Heat exchanger assembly for 910 ASME (T-M50 ASME)
445	319143-271	EM326	Connecting pipe for 910 ASME (T-M50 ASME)
446	319143-349	EZM18	O-ring P18 FKM
447	319143-278	EM370	Connecting pipe for 910 ASME (T-M50 ASME)
448	319143-310	EM456	Left cold pipe for 910 ASME (T-M50 ASME)
449	319143-313	EM459	Left hot pipe for 910 ASME (T-M50 ASME)
450	319143-312	EM458	Right hot pipe for 910 ASME (T-M50 ASME)
451	319143-311	EM457	Right cold pipe for 910 ASME (T-M50 ASME)